

THERMO FANS CATALOGUE



www.bvnair.com

GENERAL INFORMATIONS

BVN GLOBAL

We invite you to the world of Ventilation and Air Conditioning;
We offer the most efficient fan and Control systems to make your living spaces more reliable and comfortable.



From 1992 until today, BVN has been manufacturing electric motors and fans for various applications. Istanbul based production area of 30.000 m2, 400 experienced employees and has structuring in 72 countries with Global Brand Of Turkey! www.bvnair.com



We are registering our High Quality With Our Promises And Also Documents!

BVN certificated its quality with ISO 9001, ISO 14001, ISO 18001. BVN Products Follows International Standards Such as ISO and AMCA, also develops the most modern laboratory equipments and improve with the advanced technology softwares.



*TSE, CE Mark, UKR SEPRO, PCT GOST, ROHS Requirements are the standarts of BVN Products.

Our Smoke Exhaust Fans has the Fire Endurance certificates F300/H2 and F400/H2 taken from International Test Labrotories.

Before Packacing For the Each Product We deliver, We test our products performance and safety for you to use with peace.

Our Exproof Fans has the Atex Certificate.



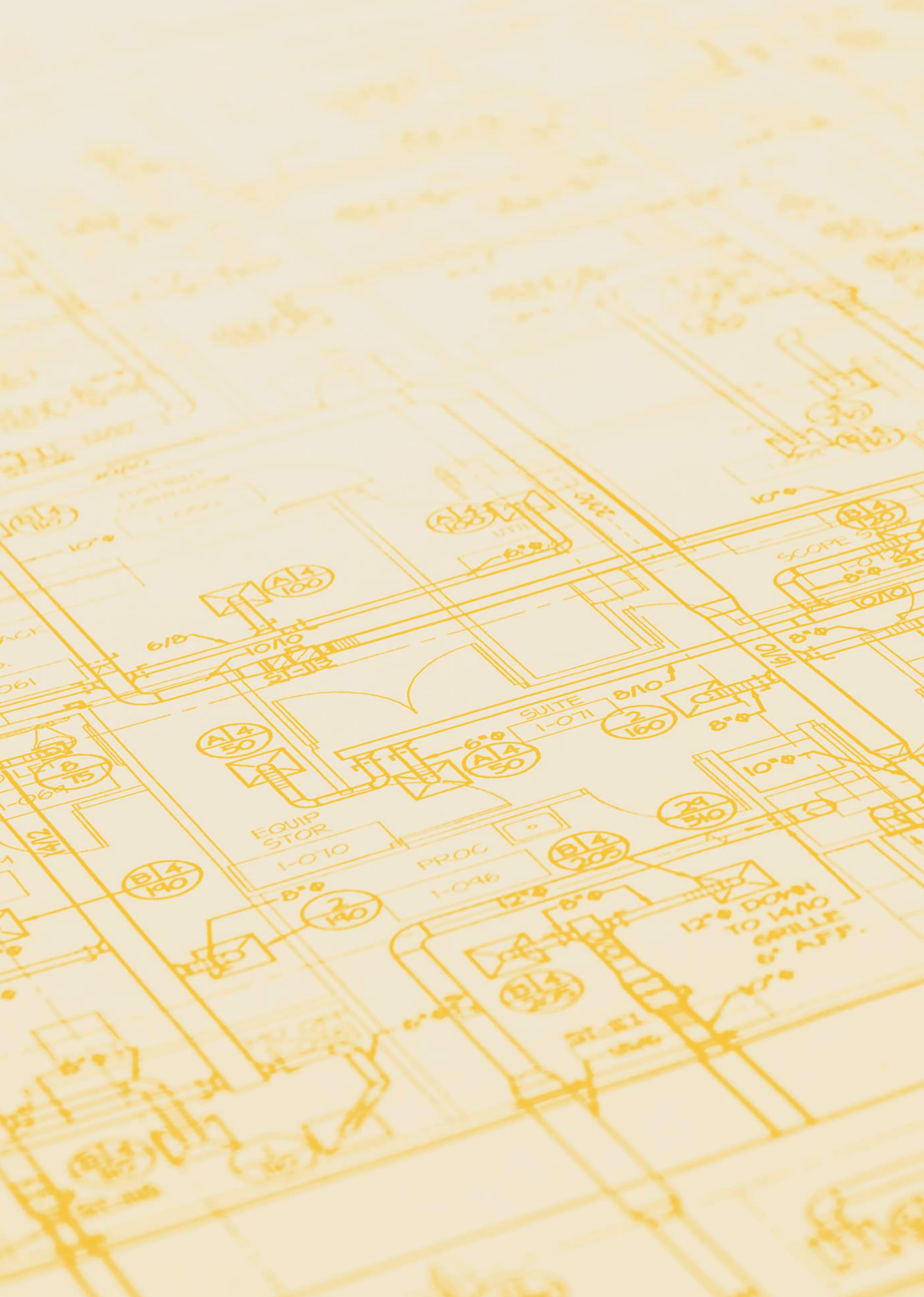



The background is a detailed architectural drawing of a kitchen, rendered in a light yellow color. It shows various kitchen fixtures, including a sink, stove, and refrigerator, along with mechanical notes and symbols. One prominent note reads "10\"/>The background is a detailed architectural drawing of a kitchen, rendered in a light yellow color. It shows various kitchen fixtures, including a sink, stove, and refrigerator, along with mechanical notes and symbols. One prominent note reads "10" DOWN TO W/O GRILLE 6" APP." and another says "10/10". There are also circular symbols with numbers like "140" and "120".

THERMO FANS

Jet Fans

Smoke Exhaust Ventilation Systems

Kitchen Exhaust Fans

THERMO FANS

Thermo Fans transport air and smoke at high temperatures with their external motor design. With its comprehensive product models, they are used in applications such as kitchen ventilations, welding fumes, cooking ovens etc.

AREA OF USE

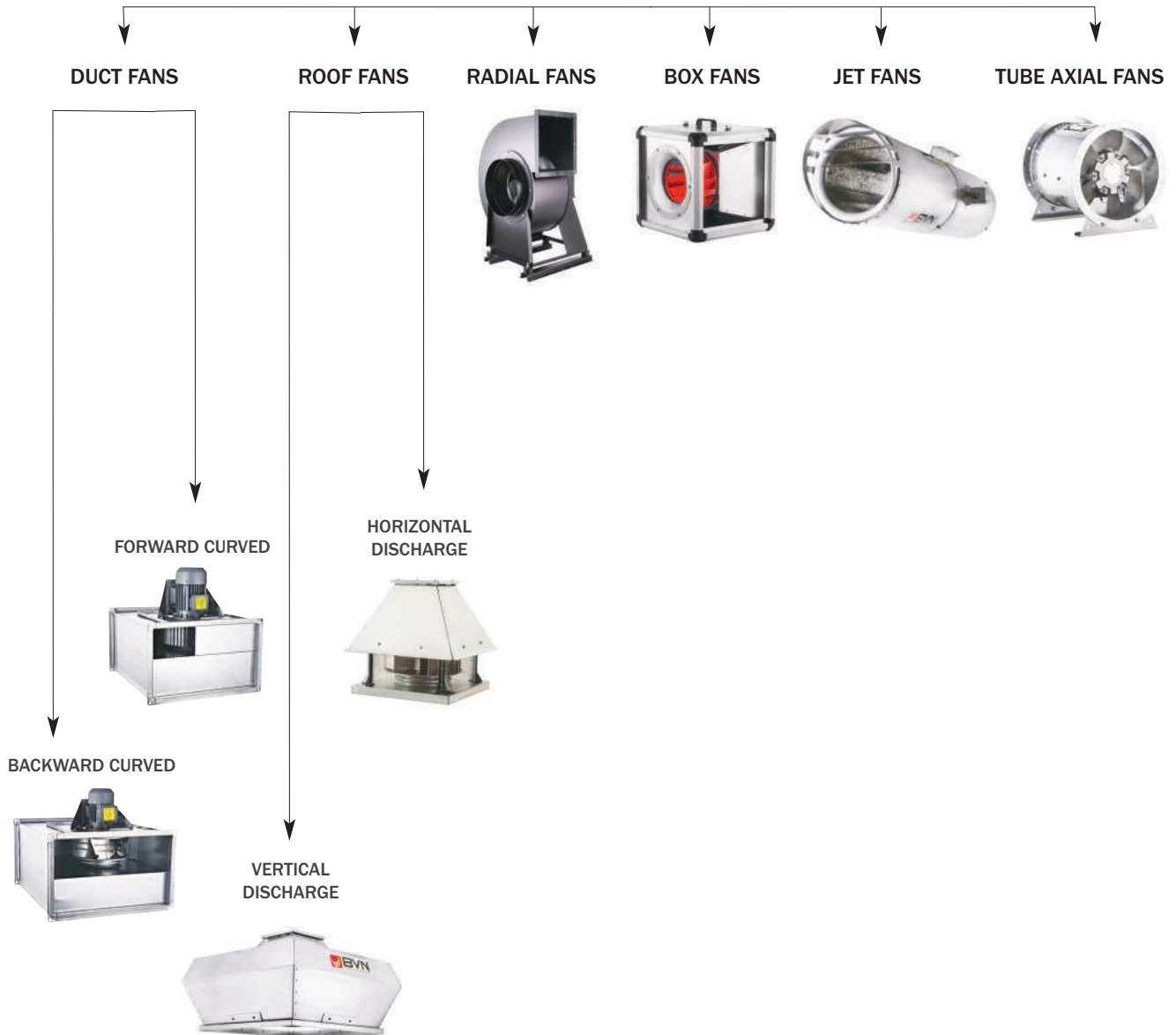





ARMO-JP

JET FANS / Axial

By providing jet flow in the outlet of the device, they are high temperature resistant fans which add toxic gases around the flow line to their own flow area and give momentum to the toxic gases and thus direct them to the exhaust points.

General Features

- EN 12101-3 and CE certificates.
- Motor and fan system are coupled to the muffler system.
- It can operate continuously for 2 hours at 400 C and 300 C.
- Products with diameters of 315,355 and 400 mm.
- Special deflector design.
- Has an aesthetic appearance.

Rotor Features

- Fire resistant aluminum alloy casting blades and fan hub.
- Ability to work in single direction and double-gauge.
- In the case of reversible wing type, it is not subject to any loss of aerodynamic loss.
- The wings are aerofoil-shaped and have high aerodynamic performance in both unidirectional and bi-directional fins.
- The fan part of the fan is dynamically balanced according to ISO 1940 and there is no eccentricity during fan operation.
- Specially designed fan hub.



Body Features

Compact design with convenient and easy installation.

Motor Features

It has 2 and 4 pole motor options. Motors are in IP 55 class and Class - H insulation.

Fan Inlet Cone

Special design fan inlet cone for minimizing noise levels to a minimum by maximizing aerodynamic characteristics and performance.

Stator

It has a special design status to minimize sound levels by maximizing aerodynamic characteristics and performance.

Input Cone

It has a special design inlet cone for minimizing the sound levels by minimizing the aerodynamic characteristics and performance.



Technical Drawing and Tables

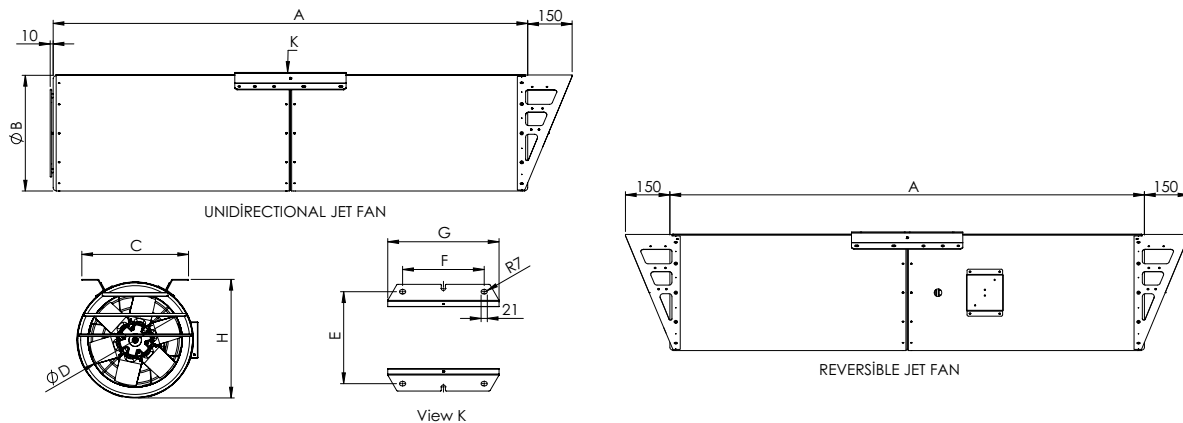

TYPE	A	B	C	D	E	F	G	H
ARMO-JP-315 UDA/RDA	1600	390	360	315	310	275	375	400
ARMO-JP-355 UDA/RDA	1700	455	410	355	360	275	375	465
ARMO-JP-400 UDA/RDA	1850	500	450	400	400	350	450	510

Dimensions are in (mm)

TYPE	VOLTAGE	FREQUENCY	POWER	CURRENT	THRUST	SPEED	AIR FLOW	SOUND PRESSURE	INSULATION CLASS	PROTECTION CLASS	WEIGHT
	V	Hz	kW	(A)	(N)	r.p.m	m ³ /h	dB(A)	Ins.cl.	IP	kg
ARMO-JP-315-UDA	400	50	0,8/0,2	1,91/0,6	25/6,3	2810/1390	4600/2300	66-49	H	55	91
ARMO-JP-355-UDA	400	50	1,1/0,25	2,2/0,55	45/11,3	2900/1435	6900/3450	70-52	H	55	98
ARMO-JP-400-UDA	400	50	1,5/0,37	3,4/0,8	75/18,7	2845/1420	10000/5000	72-53	H	55	105
ARMO-JP-315-RDA	400	50	0,8/0,2	1,91/0,6	24/6	2810/1390	4500/2250	62-45	H	55	93
ARMO-JP-355-RDA	400	50	1,1/0,25	2,2/0,55	41/10	2900/1435	6540/3270	66-48	H	55	100
ARMO-JP-400-RDA	400	50	1,5/0,37	3,4/0,8	70/17,5	2845/1420	9750/4875	68-49	H	55	107

Sound Level Measured from 3m distance in room condition.



ARMO-JR

JET FANS / Backward Curved



By providing jet flow in the outlet of the device, they are high temperature resistant fans which add toxic gases around the flow line to their own flow area and give momentum to the toxic gases and thus direct them to the exhaust points. Radial jet fans are used for the same purpose as axial jet fans. These fans have lower heights and are suitable for car parks with height less than 2.4m or with cassette access.

General Features

- EN 12101-3 and CE certificates. • Motor and fan system are coupled to the muffler system. • It can operate continuously for 2 hours at 400 C and 300 C. • Special deflector design. • Has an aesthetic appearance.

Rotor Features

- It is made of high quality galvanized steel with fire resistant. • It has the capacity to shoot in one direction. Taking the air movement in the vertical direction; completes by shooting horizontally.

- The fan part of the fan is dynamically balanced according to ISO 1940 and there is no eccentricity during fan operation. • Specially designed fan hub.

Body Features

Compact design with convenient and easy installation.

Motor Features

8, 4-pole double-speed motor. Motors are in IP 55 class and Class-H insulation.

Fan Inlet Cone

Special design fan inlet cone for minimizing noise levels to a minimum by maximizing aerodynamic characteristics and performance.

Input Cone

It has a special design inlet cone for minimizing the sound levels by minimizing the aerodynamic characteristics and performance.

Technical Drawing and Tables

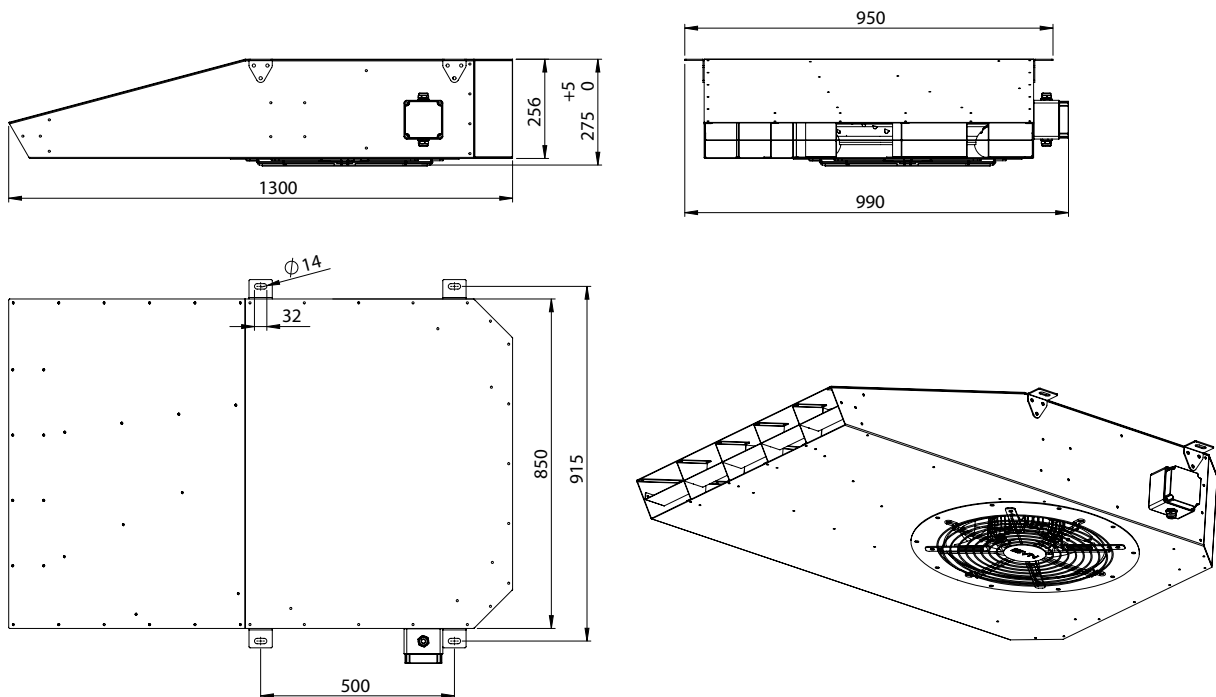

TYPE	THRUST (N)	AIR FLOW m ³ /h	POWER kW	CURRENT (A)	SPEED d/d	WEIGHT kg
ARMO-JR 50	48/12	3375/6750	0,3/1,2	1,29/2,92	705/1430	80

Sound Level Measured from 3m distance in room condition.



ARMO-A

SMOKE AND HEAT EXHAUST FANS / Tube Axial



Axial tube fans are used in pressurization fan, fresh air fan and smoke exhaust fan applications. The fan sleeve is fire resistant and designed according to the noise standard. Smoke evacuation fans are fire resistant. Smoke discharge fans can be installed vertically and horizontally according to the characteristics of the structure.

dynamically to ISO 1940 and there is no eccentricity during the operation of the fan.

Body Features

- Fan body is steel sheet. Body is hot dip galvanized and corrosion resistant. • It has short type body and long type body types.

General Features

- EN 12101-3 and CE certificates. • 2 hours continuous operation at 400 C and 300 C • There is a wide product range from 400 mm to 1250 mm.

Motor Features

- Offers 2.4 and 6-pole motors • The motors are IP 55 class and Class-H insulated. • All electric motor models are approved for continuous operation (S1) and Emergency operation (S2).

Rotor Features

- Fire resistant aluminum alloy casting blades and fan hub. • It is capable of one-way and two-way operation. The blades are specially designed according to each direction type. • There is no aerodynamic loss in the case of reversible wing type operation. • Wings are airfoil and provide high aerodynamic performance in both unidirectional and bidirectional vanes. • Wing angles are adjustable. In this way, smoke discharge fans can be demanded at different flow rates and pressures. • The fan part of the fan is balanced

Ease of Maintenance

A maintenance cover is provided to ensure easy maintenance.

Usage Areas

They are the fans that provide the combustion of toxic gases that are supplied by the jet fans to the external environment. Axial fans are used in pressurization fan, fresh air fan and smoke exhaust fan applications.



Technical Drawing and Tables

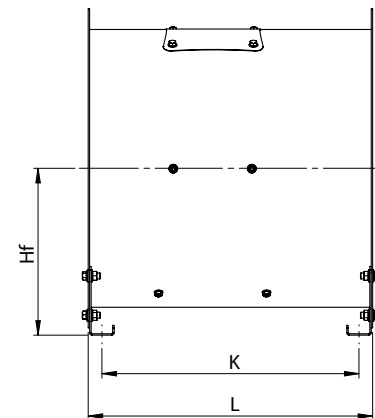
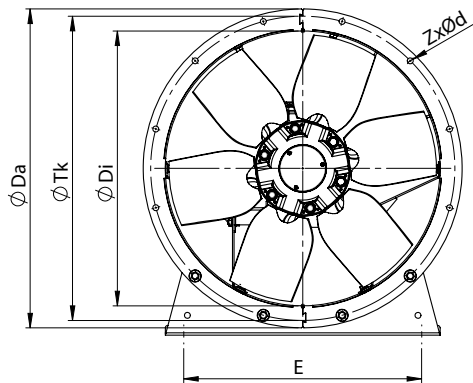

TYPE	ØDi	ØDa	ØTk	ZXØd	L	Hf	K	E
ARMO-A 400	400	480	450	8XØ12	474	255	420	335
ARMO-A 450	450	530	500	8XØ12	474	280	420	385
ARMO-A 500	500	590	560	12XØ12	580	310	524	425
ARMO-A 560	560	650	620	12XØ12	580	340	524	485
ARMO-A 630	630	720	690	12XØ12	600	375	544	555
ARMO-A 710	710	800	770	16XØ12	600	420	544	595
ARMO-A 800	800	890	860	16XØ12	700	470	634	625
ARMO-A 900	900	1005	970	16XØ15	775	527	697	675
ARMO-A 1000	1000	1105	1070	16XØ15	850	577	772	775
ARMO-A 1250	1250	1390	1320	20XØ15	949	720	861	950

Dimensions are in (mm)

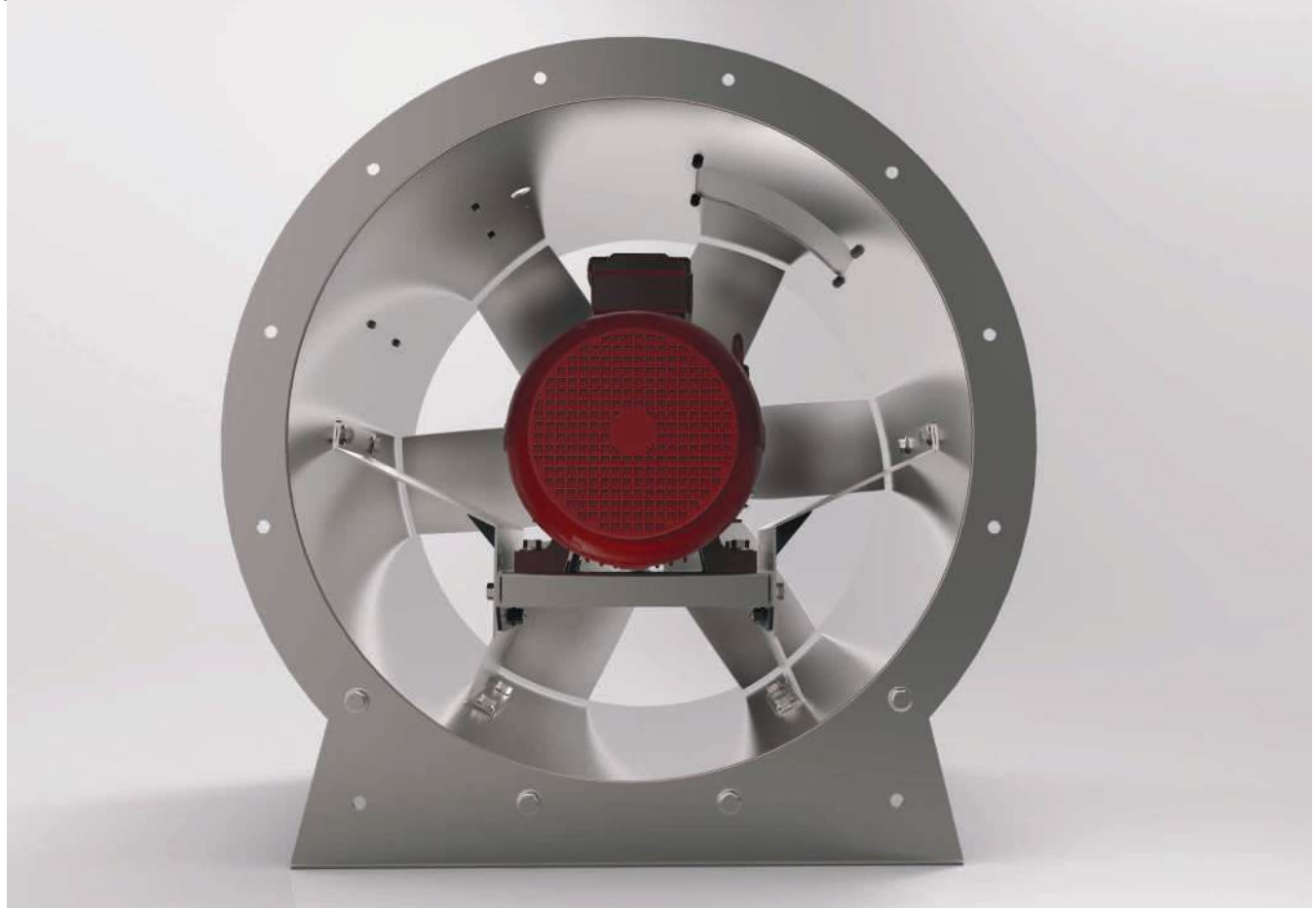

2 POLE TYPE	SPEED	DIAMETER	POWER	CURRENT	AIR FLOW	WING ANGLE
	r.p.m	mm	kW	230V - 400V	m ³ /h	
ARMO-A / 400-6 / 0,75 - 2A	2900	400	0,75	1,6	5250	16°
ARMO-A / 400-6 / 1,1 - 2A	2900	400	1,1	2,3	6904	22°
ARMO-A / 400-6 / 1,5 - 2A	2900	400	1,5	3,4	8978	30°
ARMO-A / 400-6 / 2,2 - 2A	2900	400	2,2	4,48	9975	34°
ARMO-A / 450-6 / 1,1 - 2A	2900	450	1,1	2,3	6248	10°
ARMO-A / 450-6 / 1,5 - 2A	2900	450	1,5	3,4	8610	16°
ARMO-A / 450-6 / 2,2 - 2A	2900	450	2,2	4,48	11970	24°
ARMO-A / 450-6 / 3 - 2A	2900	450	3	6	13545	28°
ARMO-A / 500-6 / 2,2 - 2A	2900	500	2,2	4,48	11000	14°
ARMO-A / 500-6 / 3 - 2A	2900	500	3	6	14595	20°
ARMO-A / 500-6 / 4 - 2A	2900	500	4	7,4	17325	26°
ARMO-A / 500-6 / 5,5 - 2A	2900	500	5,5	11	18375	28°
ARMO-A / 560-6 / 4 - 2A	2900	560	4	7,4	17850	14°
ARMO-A / 560-6 / 5,5 - 2A	2900	560	5,5	11	22313	20°
ARMO-A / 560-6 / 7,5 - 2A	2800	560	7,5	13,6	25725	24°
ARMO-A / 630-6 / 5,5 - 2A	2900	630	5,5	11	20475	10°
ARMO-A / 630-6 / 7,5 - 2A	2800	630	7,5	13,6	27300	16°

4 POLE TYPE	SPEED	DIAMETER	POWER	CURRENT	AIR FLOW	WING ANGLE
	r.p.m	mm	kW	230V - 400V	m ³ /h	
ARMO-A / 500-6 / 0,55- 4A	1415	500	0,55	1,6	8715	26
ARMO-A / 500-6 / 0,75- 4A	1350	500	0,75	2,1	10290	32
ARMO-A / 500-6 / 1,1- 4A	1400	500	1,1	2,6	12600	38
ARMO-A / 560-6 / 0,55- 4A	1415	560	0,55	1,6	9870	16
ARMO-A / 560-6 / 0,75- 4A	1350	560	0,75	2,1	12075	22
ARMO-A / 560-6 / 1,1- 4A	1400	560	1,1	2,6	13860	26
ARMO-A / 560-6 / 1,5- 4A	1405	560	1,5	3,5	15750	32
ARMO-A / 560-6 / 2,2- 4A	1410	560	2,2	5	17850	38
ARMO-A / 630-6 / 0,75- 4A	1350	630	0,75	2,1	10605	10
ARMO-A / 630-6 / 1,1- 4A	1400	630	1,1	2,6	16275	20
ARMO-A / 630-6 / 1,5- 4A	1405	630	1,5	3,5	18375	24
ARMO-A / 630-6 / 2,2- 4A	1410	630	2,2	5	21525	30
ARMO-A / 630-6 / 3- 4A	1410	630	3	6,6	24150	36
ARMO-A / 630-6 / 4- 4A	1500	630	4	8,2	25200	38
ARMO-A / 710-3 / 0,75- 4A	1350	710	0,75	2,1	14175	10
ARMO-A / 710-3 / 1,1- 4A	1400	710	1,1	2,6	18375	16
ARMO-A / 710-3 / 1,5- 4A	1405	710	1,5	3,5	21000	20
ARMO-A / 710-3 / 2,2- 4A	1410	710	2,2	5	24413	26
ARMO-A / 710-3 / 3- 4A	1410	710	3	6,6	27825	32
ARMO-A / 710-6 / 1,1- 4A	1400	710	1,1	2,6	16275	12
ARMO-A / 710-6 / 1,5- 4A	1405	710	1,5	3,5	20475	18
ARMO-A / 710-6 / 2,2- 4A	1410	710	2,2	5	23625	22
ARMO-A / 710-6 / 3- 4A	1410	710	3	6,6	28350	28
ARMO-A / 710-6 / 4- 4A	1415	710	4	8,2	31500	32
ARMO-A / 800-6 / 2,2- 4A	1410	800	2,2	5	24150	14
ARMO-A / 800-6 / 3- 4A	1410	800	3	6,6	30450	20
ARMO-A / 800-6 / 4- 4A	1415	800	4	8,2	32550	22
ARMO-A / 800-6 / 5,5- 4A	1430	800	5,5	11,2	38850	28
ARMO-A / 800-6 / 7,5- 4A	1440	800	7,5	15,4	42525	32
ARMO-A / 800-9 / 2,2- 4A	1410	800	2,2	5	16275	10
ARMO-A / 800-9 / 3- 4A	1410	800	3	6,6	21525	14
ARMO-A / 800-9 / 4- 4A	1415	800	4	8,2	29400	20
ARMO-A / 800-9 / 5,5- 4A	1430	800	5,5	11,2	36488	26
ARMO-A / 800-9 / 7,5- 4A	1440	800	7,5	15,4	40950	30
ARMO-A / 800-9 / 11- 4A	1450	800	11	21	43050	32
ARMO-A / 900-6 / 4- 4A	1415	900	4	8,2	31500	12
ARMO-A / 900-6 / 5,5- 4A	1430	900	5,5	11,2	38850	16
ARMO-A / 900-6 / 7,5- 4A	1440	900	7,5	15,4	47775	22
ARMO-A / 900-6 / 11- 4A	1450	900	11	21	56700	28
ARMO-A / 900-6 / 15- 4A	1450	900	15	29,3	60900	32
ARMO-A / 900-9 / 4- 4A	1415	900	4	8,2	26775	10
ARMO-A / 900-9 / 5,5- 4A	1430	900	5,5	11,2	34125	14
ARMO-A / 900-9 / 7,5- 4A	1440	900	7,5	15,4	41213	18
ARMO-A / 900-9 / 11- 4A	1450	900	11	21	54600	26
ARMO-A / 900-9 / 15- 4A	1450	900	15	29,3	63525	32
ARMO-A / 1000-6 / 5,5- 4A	1430	1000	5,5	11,2	38850	12
ARMO-A / 1000-6 / 7,5- 4A	1440	1000	7,5	15,4	47775	18
ARMO-A / 1000-6 / 11- 4A	1450	1000	11	21	56700	22
ARMO-A / 1000-6 / 15- 4A	1450	1000	15	29,3	60900	28
ARMO-A / 1000-6 / 18,5- 4A	1455	1000	18,5	34,5	56700	32
ARMO-A / 1000-9 / 7,5- 4A	1440	1000	7,5	15,4	43050	12
ARMO-A / 1000-9 / 11- 4A	1450	1000	11	21	55650	18
ARMO-A / 1000-9 / 15- 4A	1450	1000	15	29,3	69300	24
ARMO-A / 1000-9 / 18,5- 4A	1455	1000	18,5	34,5	77700	28
ARMO-A / 1000-9 / 22- 4A	1460	1000	22	42,5	81900	30
ARMO-A / 1000-9 / 30- 4A	1460	1000	30	55	86100	32
ARMO-A / 1250-6 / 15- 4A	1450	1250	15	29,3	90300	12
ARMO-A / 1250-6 / 18,5- 4A	1455	1250	18,5	34,5	103950	16
ARMO-A / 1250-6 / 22- 4A	1460	1250	22	42,5	109725	18
ARMO-A / 1250-6 / 30- 4A	1460	1250	30	55	122850	22
ARMO-A / 1250-6 / 37- 4A	1470	1250	37	67	136500	26
ARMO-A / 1250-6 / 45- 4A	1475	1250	45	80	155400	32
ARMO-A / 1250-9 / 18,5- 4A	1455	1250	18,5	34,5	89250	12
ARMO-A / 1250-9 / 22- 4A	1460	1250	22	42,5	97650	14
ARMO-A / 1250-9 / 30- 4A	1460	1250	30	55	114975	18
ARMO-A / 1250-9 / 37- 4A	1470	1250	37	67	131250	22
ARMO-A / 1250-9 / 45- 4A	1475	1250	45	80	138600	24

6 POLE TYPE	SPEED	DIAMETER	POWER	CURRENT	AIR FLOW	WING ANGLE
	r.p.m	mm	kW	230V - 400V	m ³ /h	
ARMO-A / 500-6 / 0,37 - 6A	900	500	0,37	1,1	8400	38
ARMO-A / 560-6 / 0,37 - 6A	900	560	0,37	1,1	10500	32
ARMO-A / 560-6 / 0,55 - 6A	930	560	0,55	1,5	11760	38
ARMO-A / 630-6 / 0,37 - 6A	900	630	0,37	1,1	11576	22
ARMO-A / 630-6 / 0,55 - 6A	930	630	0,55	1,5	13650	28
ARMO-A / 630-6 / 0,75 - 6A	945	630	0,75	2	14963	32
ARMO-A / 630-6 / 1,1 - 6A	945	630	1,1	2,9	16800	38
ARMO-A / 710-3 / 0,37 - 6A	900	710	0,37	1,1	13125	18
ARMO-A / 710-3 / 0,55 - 6A	930	710	0,55	1,5	16538	26
ARMO-A / 710-3 / 0,75 - 6A	945	710	0,75	2	18900	32
ARMO-A / 710-6 / 1,1 - 6A	945	710	1,1	2,9	11025	12
ARMO-A / 710-6 / 1,5 - 6A	945	710	1,5	3,6	13000	16
ARMO-A / 710-6 / 2,2 - 6A	950	710	2,2	5,4	13750	22
ARMO-A / 710-6 / 3 - 6A	950	710	3	6,9	18900	28
ARMO-A / 710-6 / 4 - 6A	955	710	4	9	21000	32
ARMO-A / 800-6 / 0,55 - 6A	930	800	0,55		13125	10
ARMO-A / 800-6 / 1,1 - 6A	945	800	1,1	2,9	22050	22
ARMO-A / 800-6 / 1,5 - 6A	945	800	1,5	3,6	25200	26
ARMO-A / 800-6 / 2,2 - 6A	950	800	2,2	5,4	28350	32
ARMO-A / 800-9 / 0,75 - 6A	945	800	0,75	2	14700	14
ARMO-A / 800-9 / 1,1 - 6A	945	800	1,1	2,9	19950	20
ARMO-A / 800-9 / 1,5 - 6A	945	800	1,5	3,6	23100	24
ARMO-A / 800-9 / 2,2 - 6A	950	800	2,2	5,4	27300	30
ARMO-A / 800-9 / 3 - 6A	950	800	3	6,9	28350	32
ARMO-A / 900-6 / 1,1 - 6A	945	900	1,1	2,9	23100	14
ARMO-A / 900-6 / 1,5 - 6A	945	900	1,5	3,6	25200	16
ARMO-A / 900-6 / 2,2 - 6A	950	900	2,2	5,4	31500	22
ARMO-A / 900-6 / 3 - 6A	950	900	3	6,9	36750	28
ARMO-A / 900-6 / 4 - 6A	955	900	4	9	40950	32
ARMO-A / 900-9 / 1,5 - 6A	945	900	1,5	3,6	23100	14
ARMO-A / 900-9 / 2,2 - 6A	950	900	2,2	5,4	27300	20
ARMO-A / 900-9 / 3 - 6A	950	900	3	6,9	35700	24
ARMO-A / 900-9 / 4 - 6A	955	900	4	9	39900	30
ARMO-A / 900-9 / 5,5 - 6A	985	900	5,5	12,3	43050	32
ARMO-A / 1000-6 / 1,5 - 6A	945	1000	1,5	3,6	26250	10
ARMO-A / 1000-6 / 2,2 - 6A	950	1000	2,2	5,4	34650	16
ARMO-A / 1000-6 / 3 - 6A	950	1000	3	6,9	44100	22
ARMO-A / 1000-6 / 4 - 6A	955	1000	4	9	49350	26
ARMO-A / 1000-6 / 5,5 - 6A	985	1000	5,5	12,3	55650	32
ARMO-A / 1000-9 / 2,2 - 6A	950	1000	2,2	5,4	32550	14
ARMO-A / 1000-9 / 3 - 6A	950	1000	3	6,9	39900	20
ARMO-A / 1000-9 / 4 - 6A	955	1000	4	9	43050	22
ARMO-A / 1000-9 / 5,5 - 6A	985	1000	5,5	12,3	52500	28
ARMO-A / 1000-9 / 7,5 - 6A	960	1000	7,5	15	57750	32
ARMO-A / 1250-6 / 4 - 6A	955	1250	4	9	60900	12
ARMO-A / 1250-6 / 5,5 - 6A	985	1250	5,5	12,3	63300	16
ARMO-A / 1250-6 / 7,5 - 6A	960	1250	7,5	15	76650	20
ARMO-A / 1250-6 / 11 - 6A	960	1250	11	22	92400	26
ARMO-A / 1250-6 / 15 - 6A	965	1250	15	29	105000	32
ARMO-A / 1250-9 / 7,5 - 6A	960	1250	7,5	15	73500	16
ARMO-A / 1250-9 / 11 - 6A	960	1250	11	22	88200	22
ARMO-A / 1250-9 / 15 - 6A	965	1250	15	29	105000	28
ARMO-A / 1250-9 / 18,5 - 6A	970	1250	18,5	36,5	115500	32

Accessories



BSC-F



BESB



BKFB



BSST



BTEK



BTY



BBDD

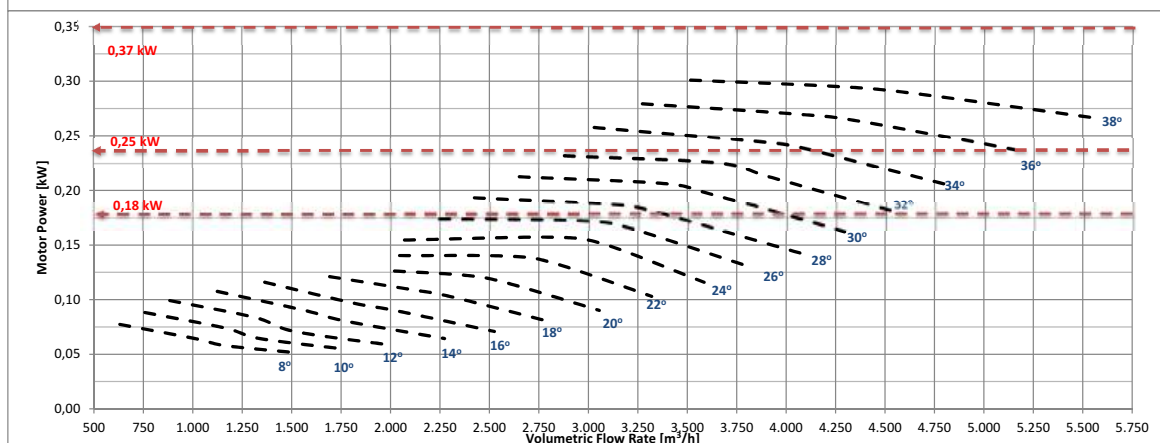
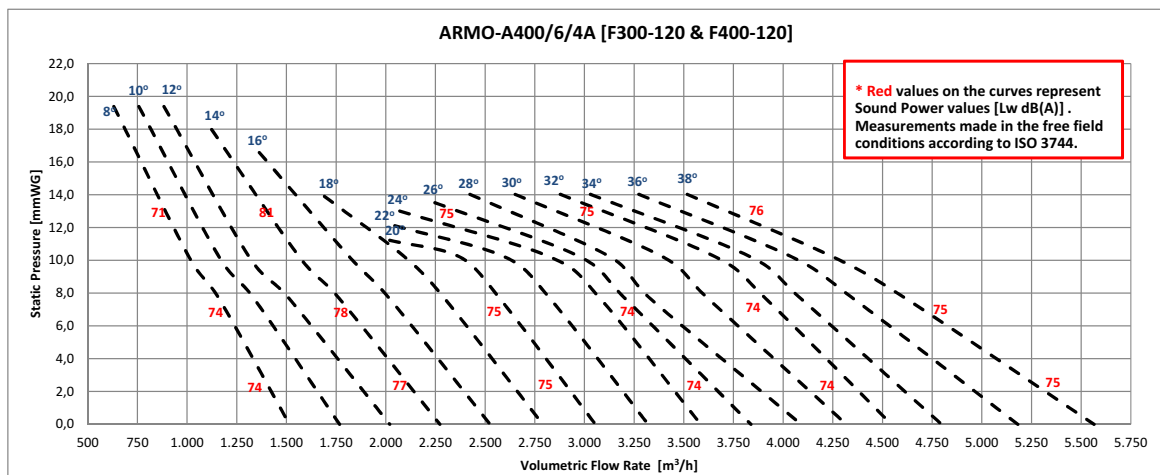
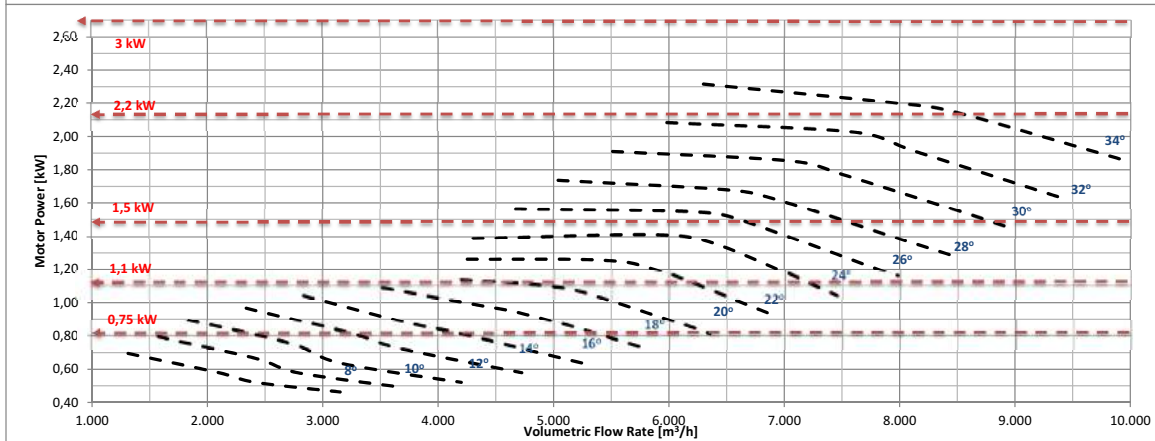
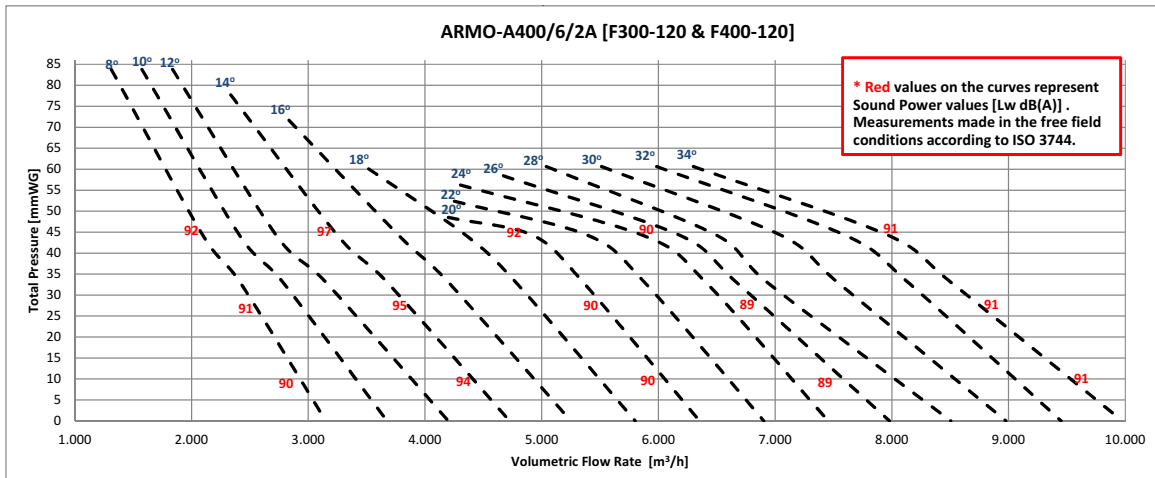

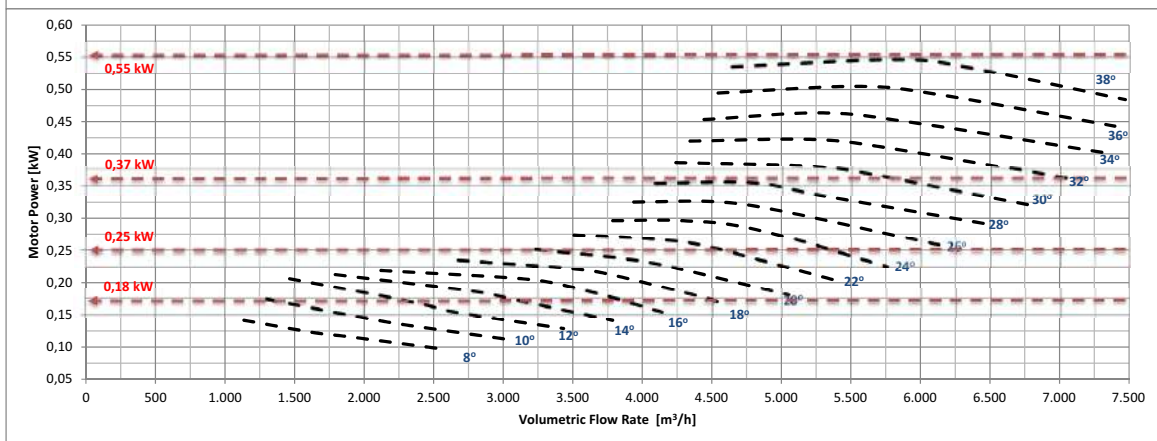
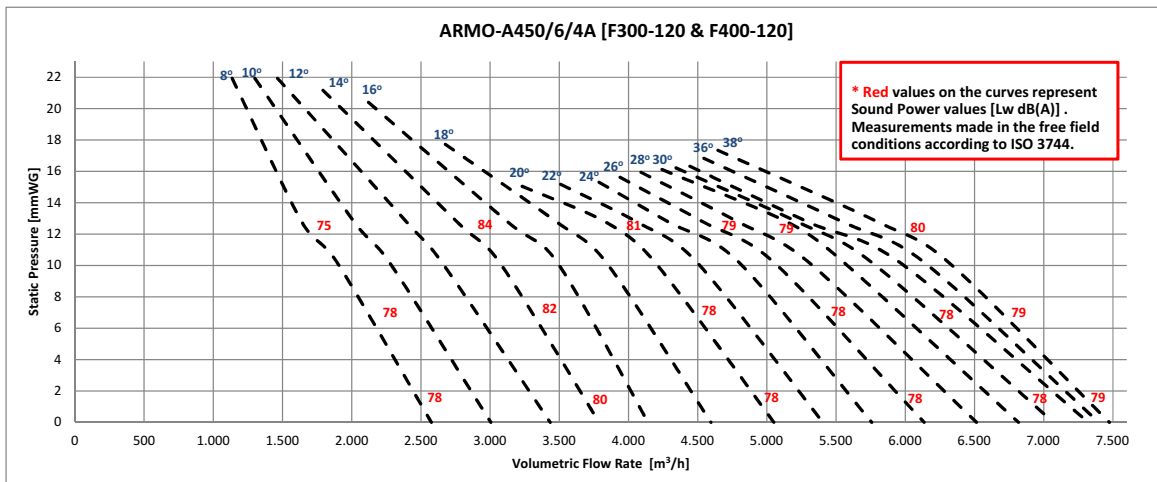
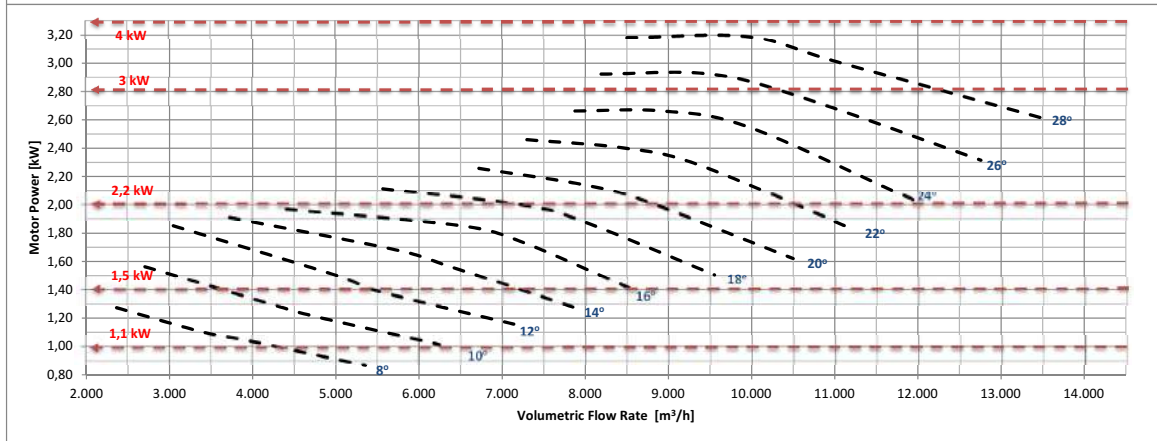
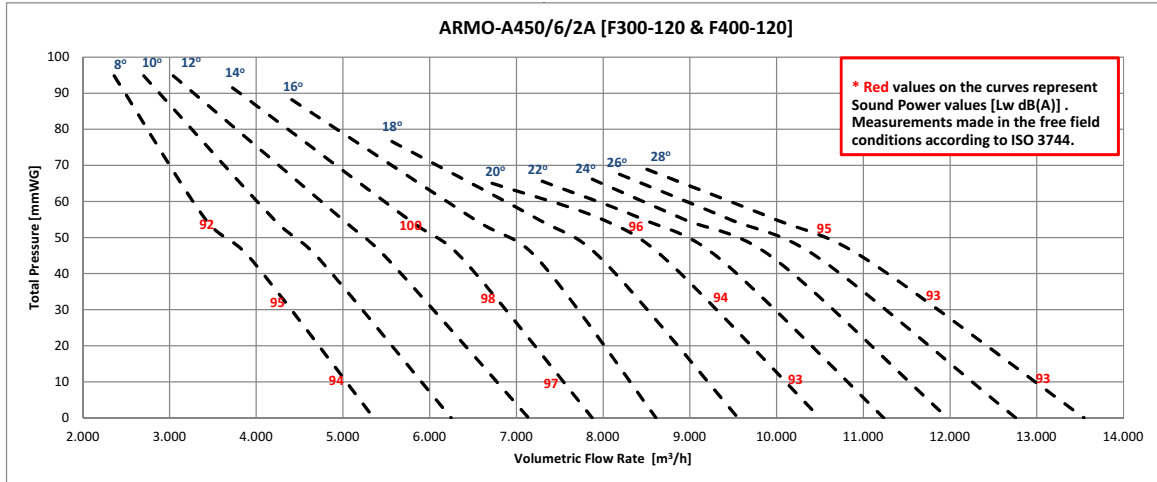

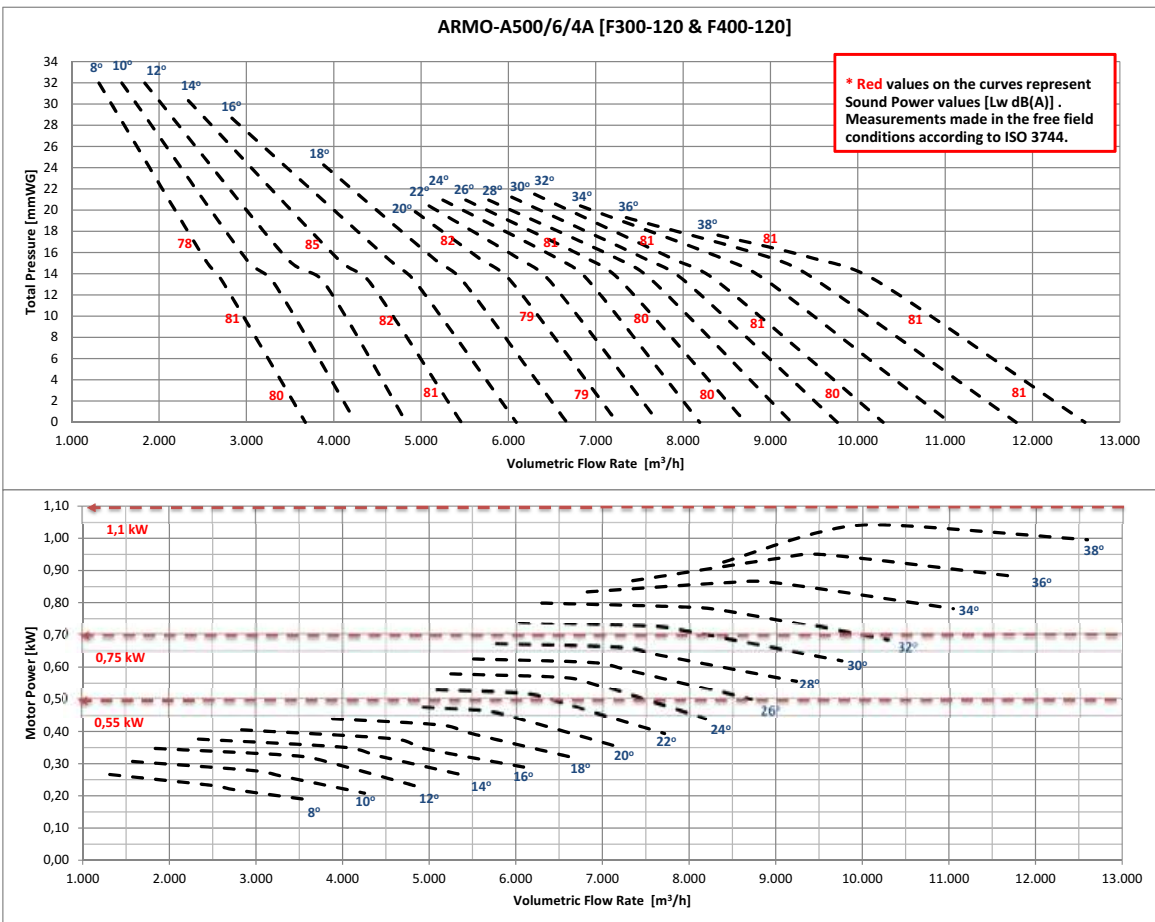
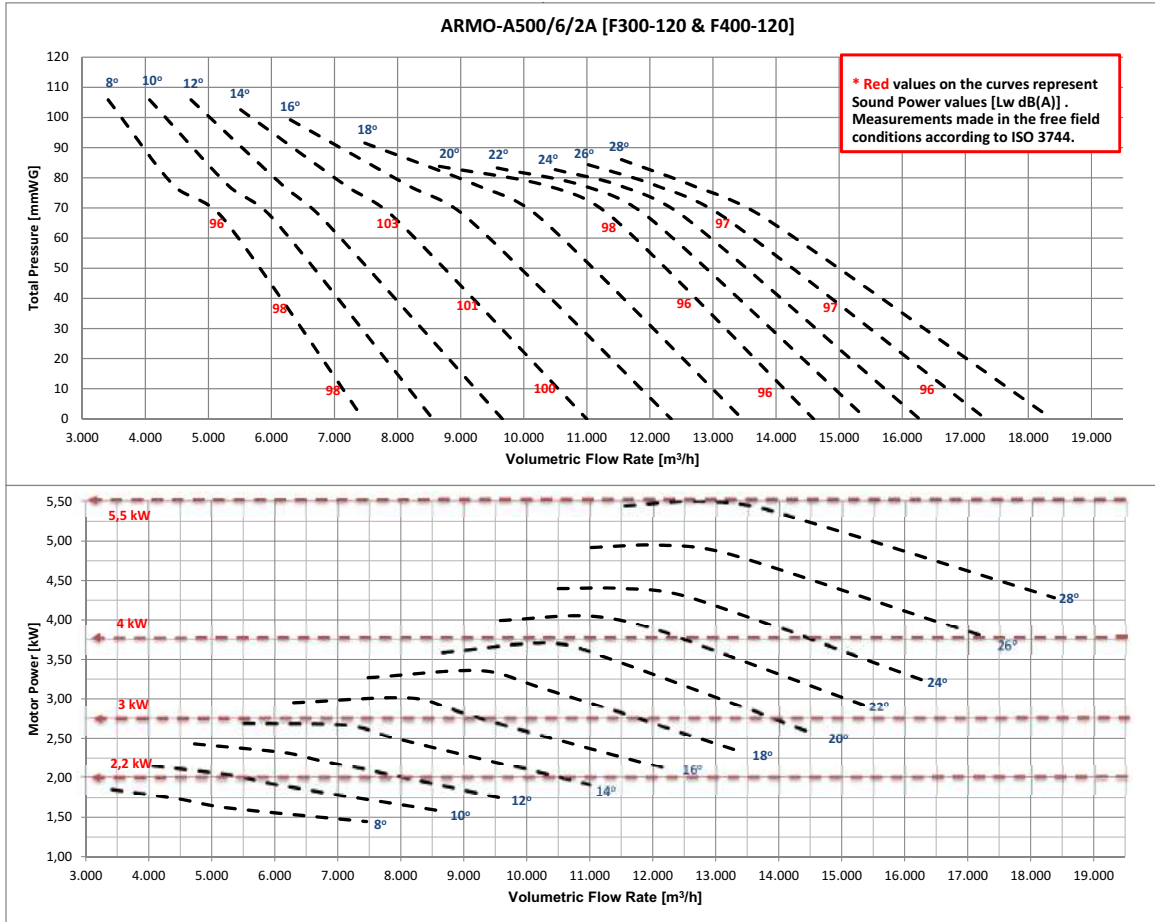

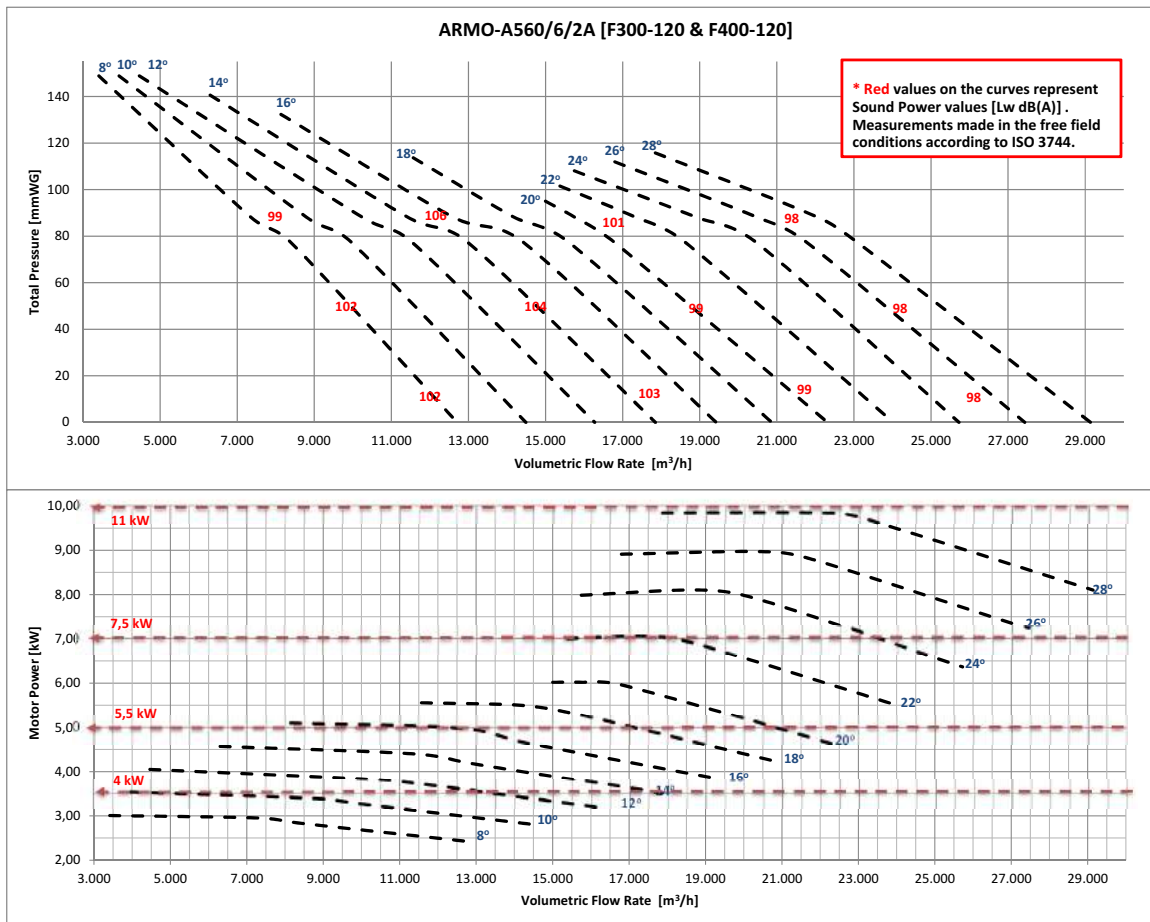
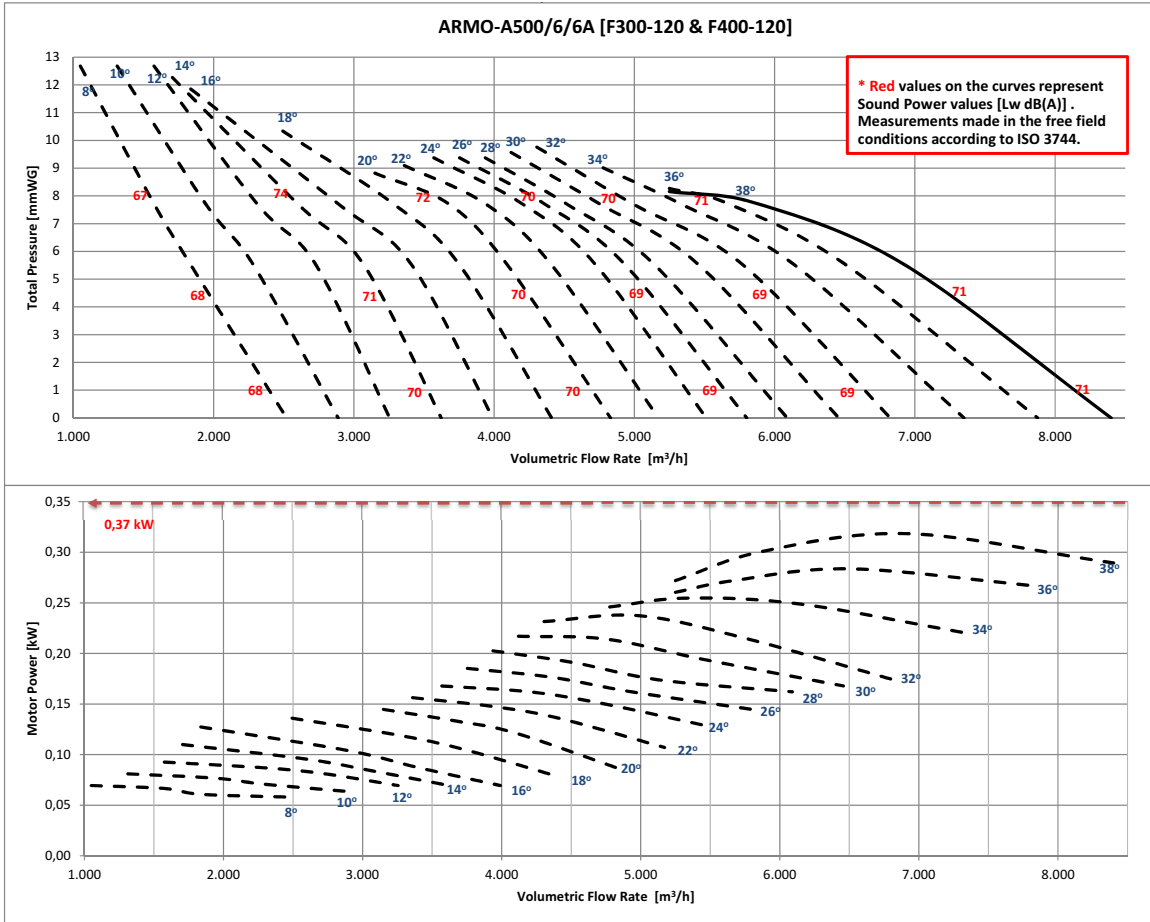

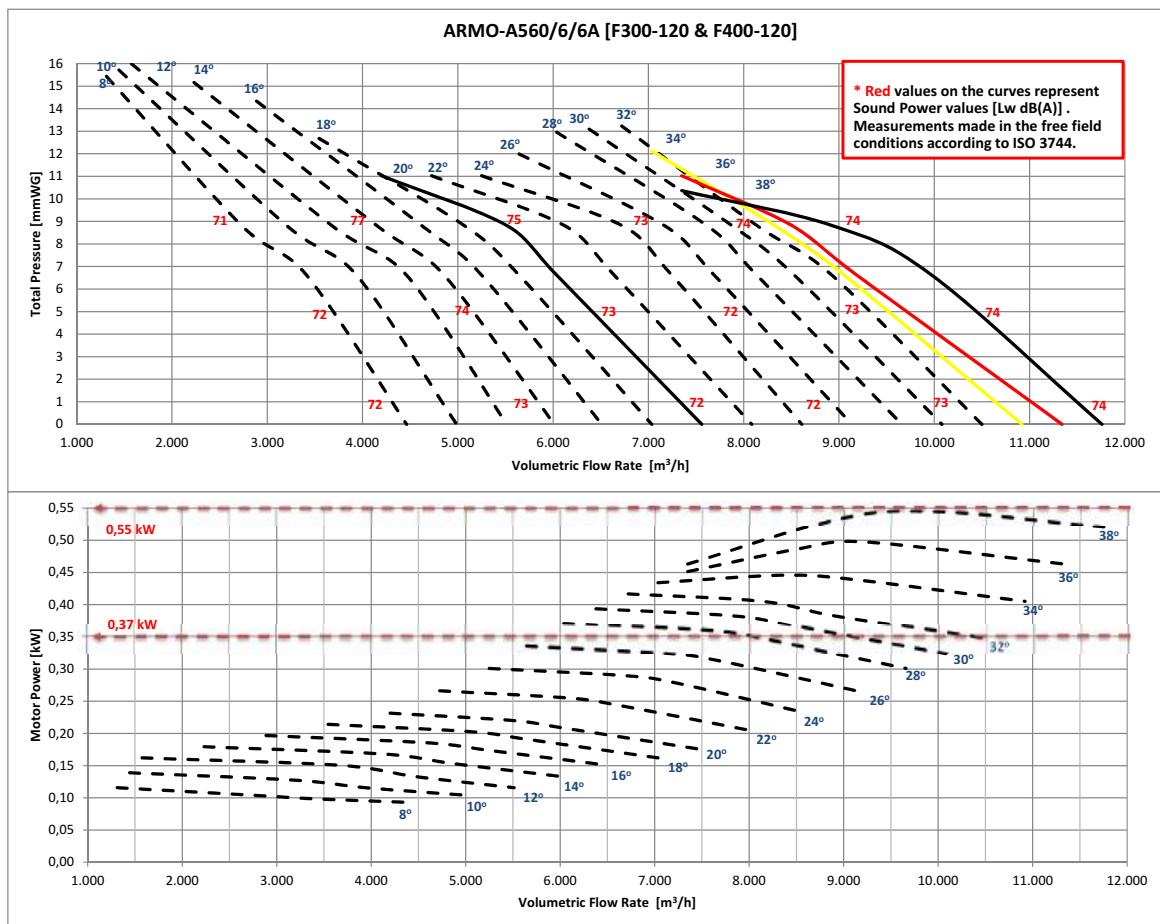
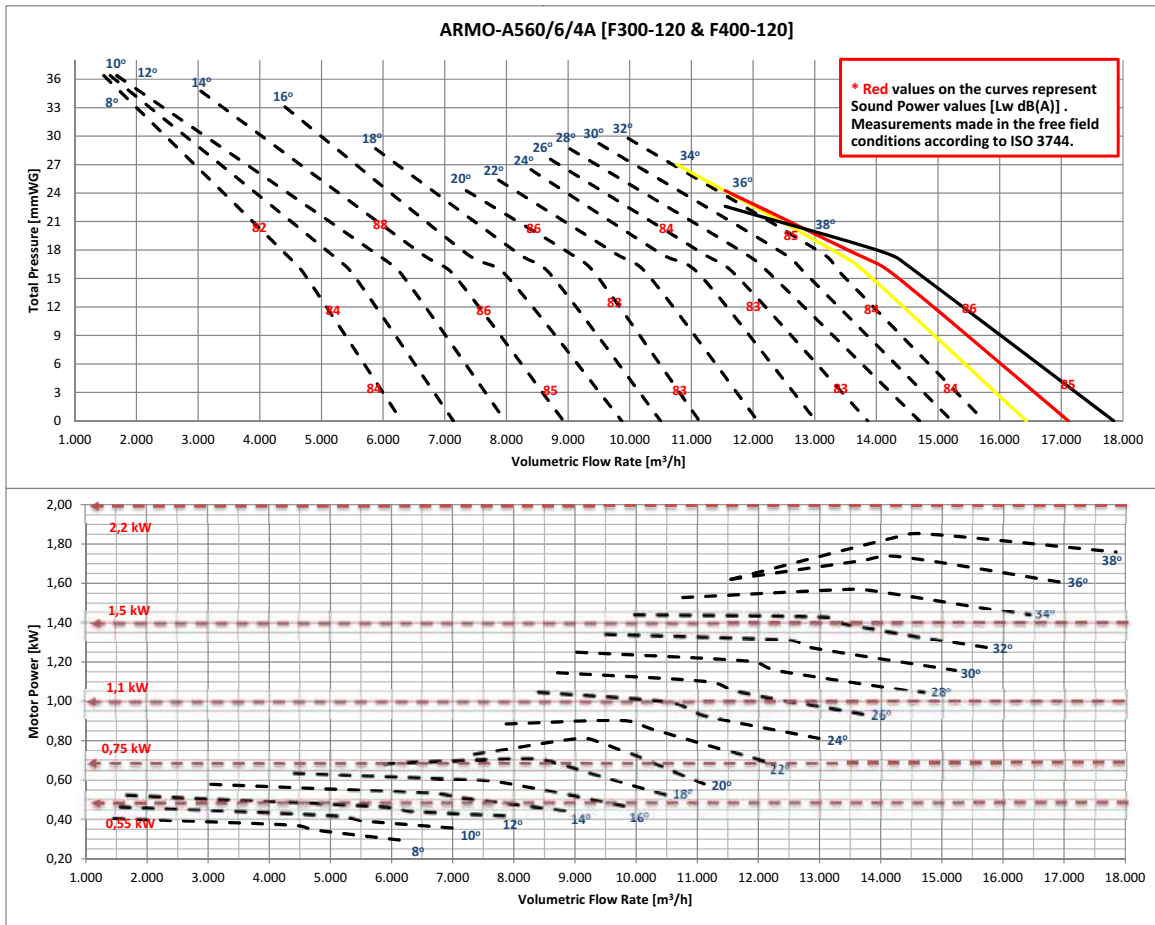

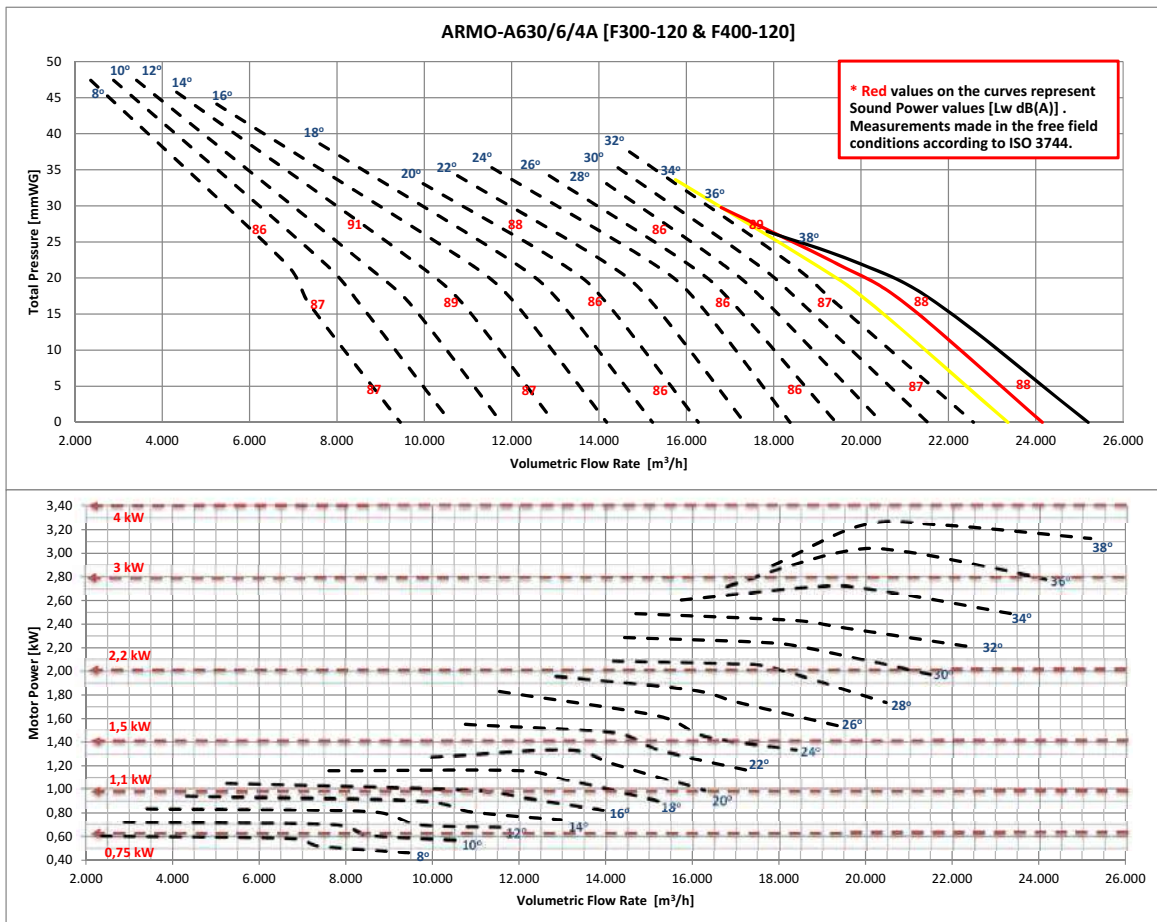
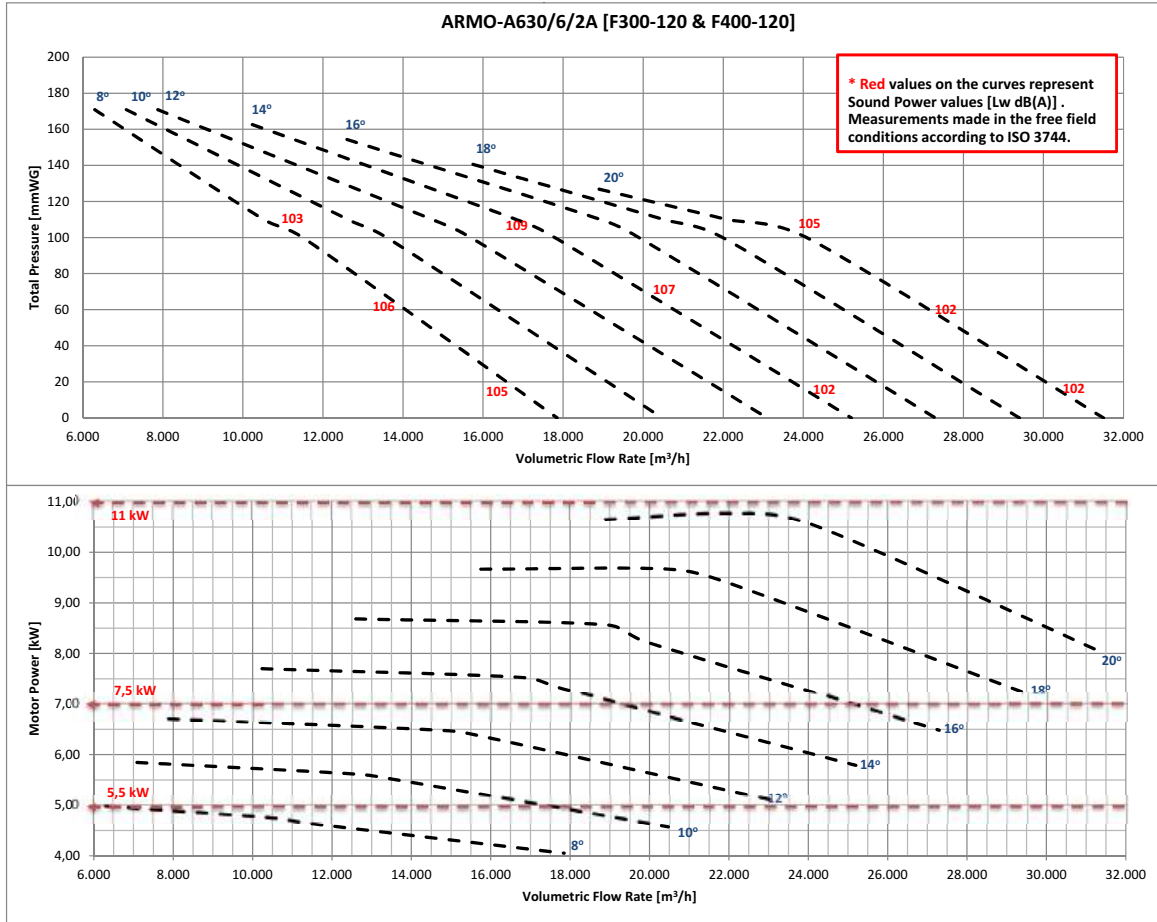

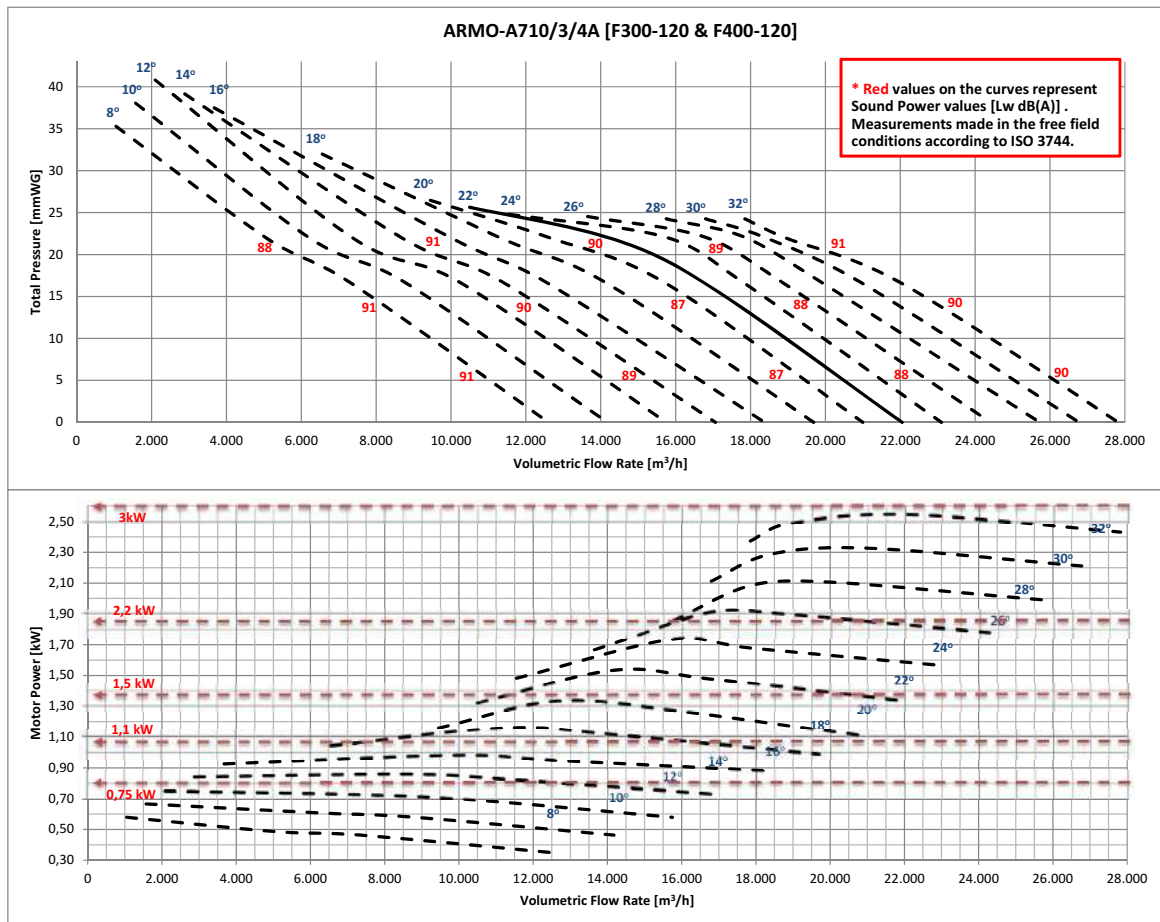
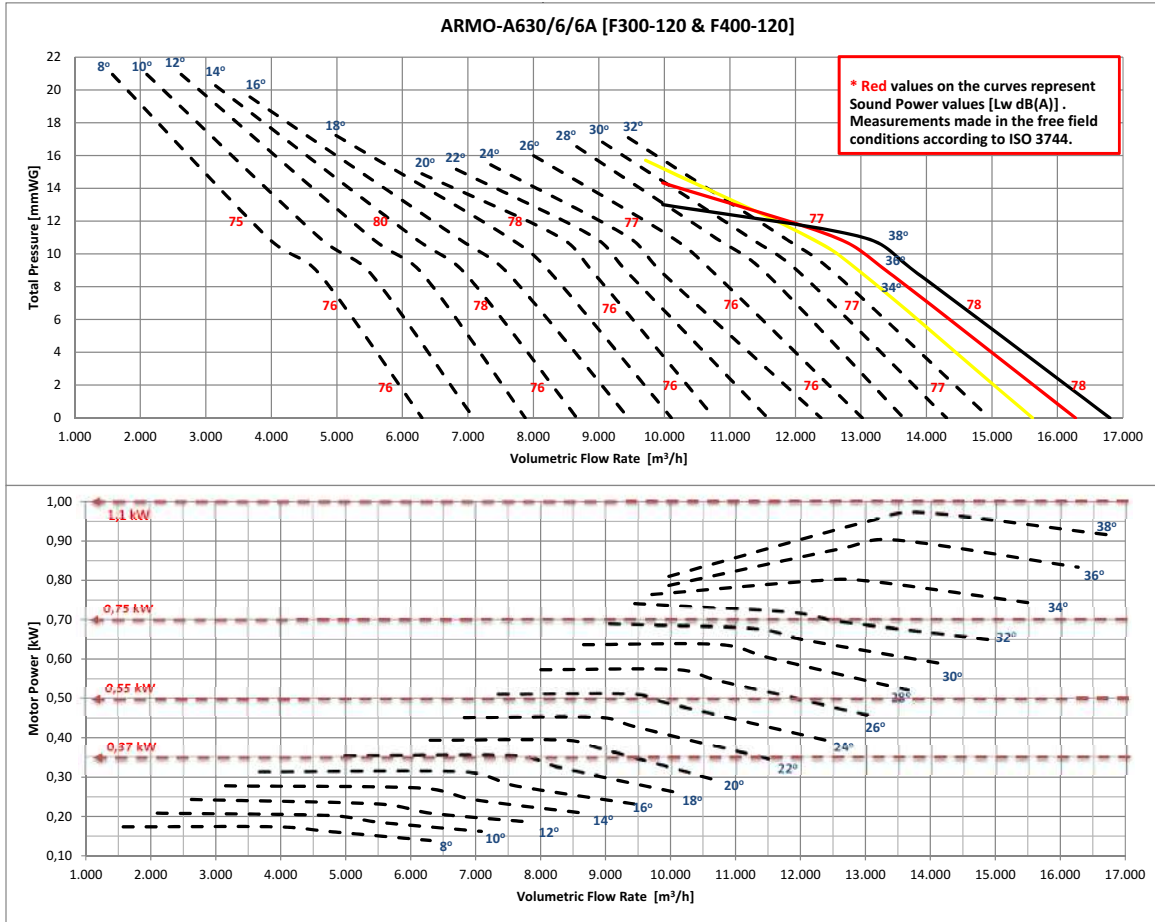

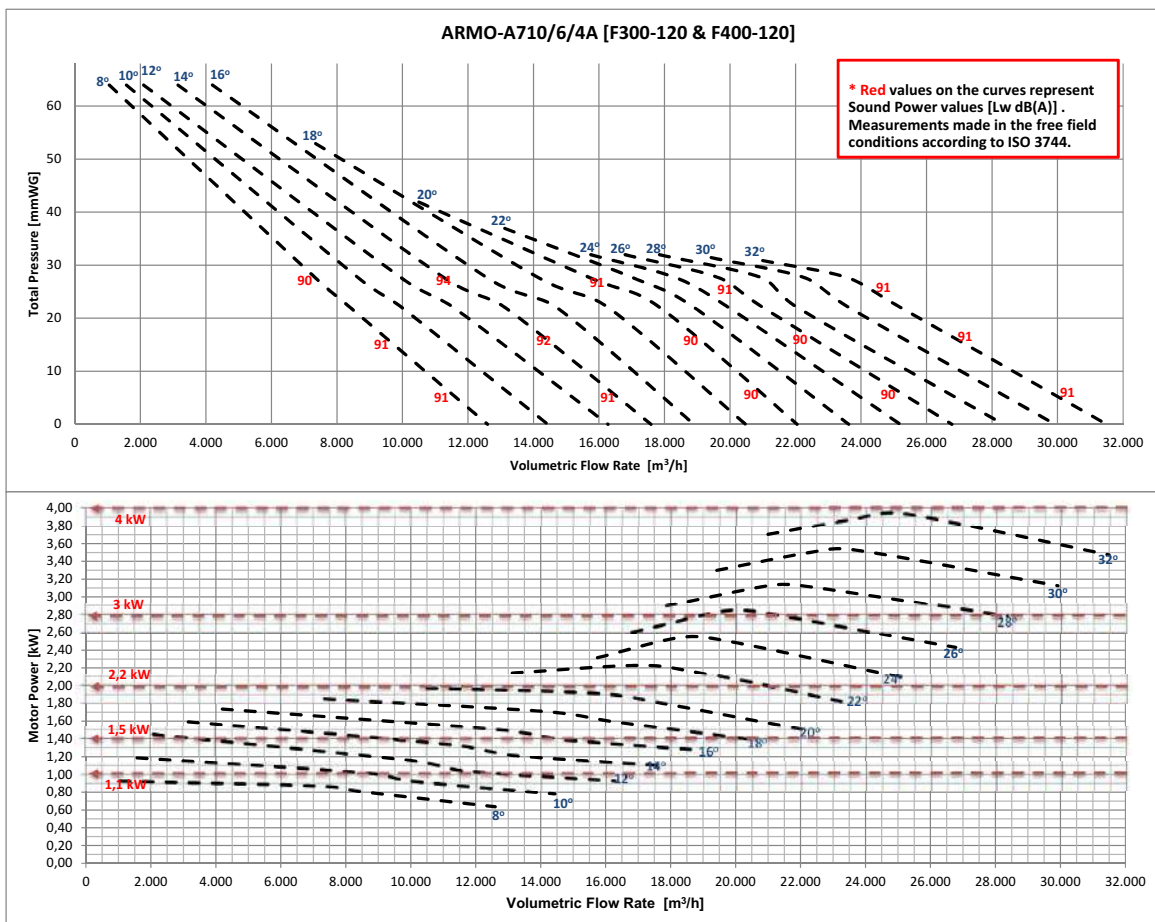
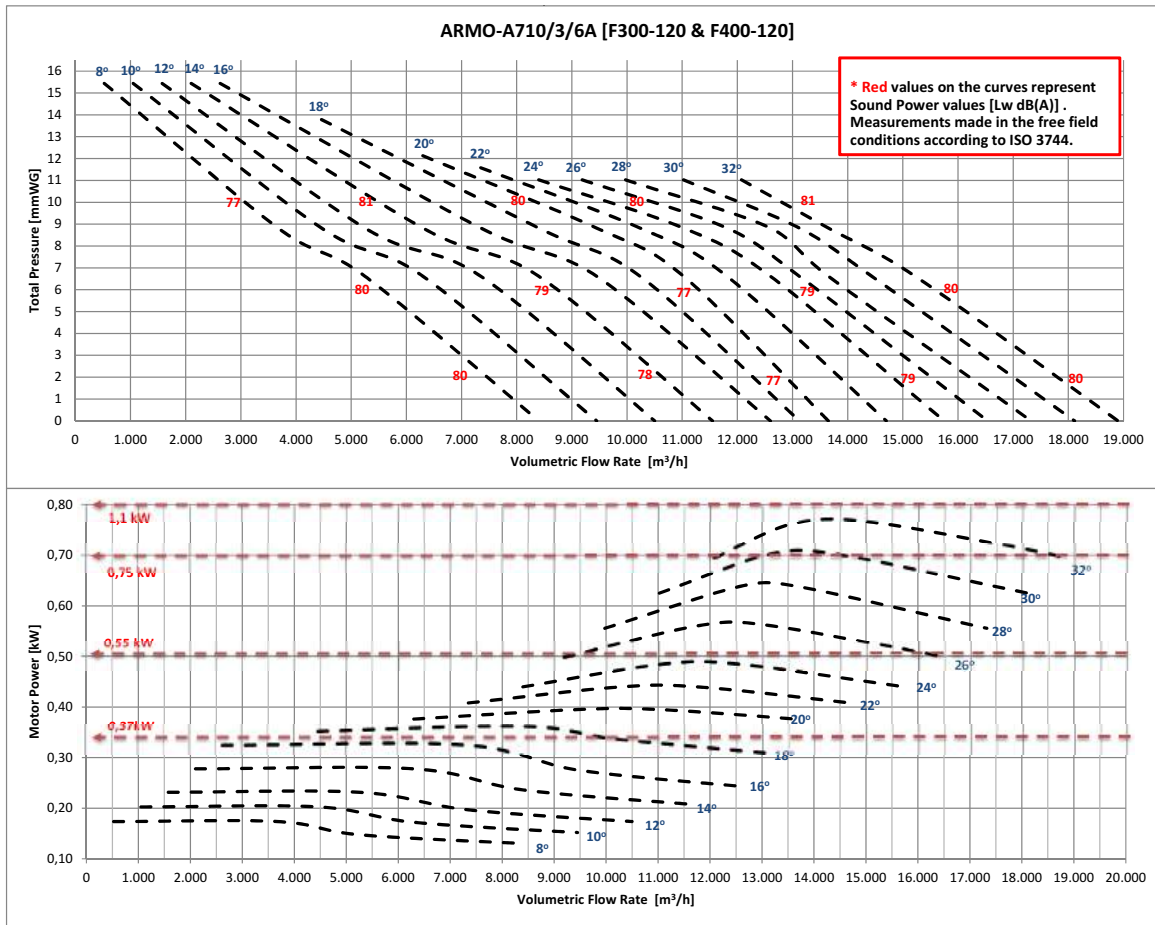

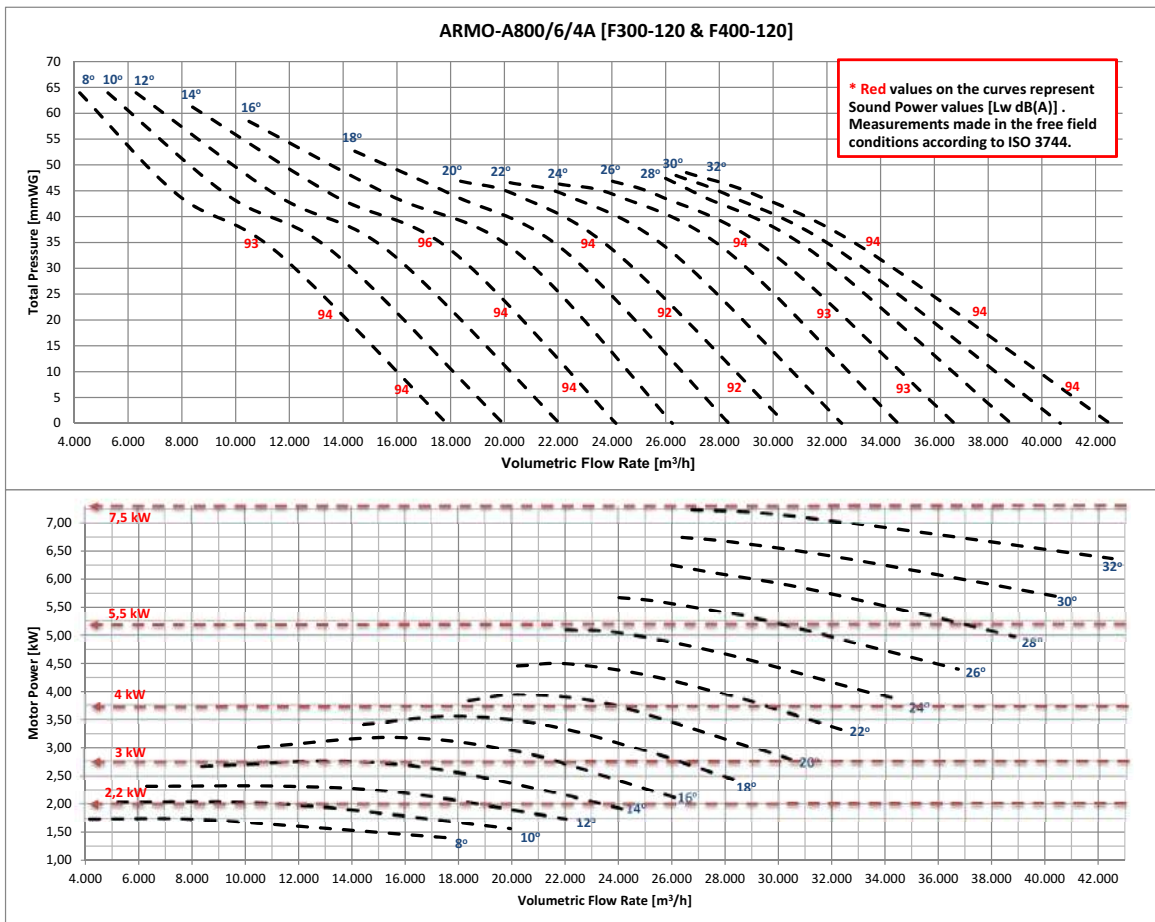
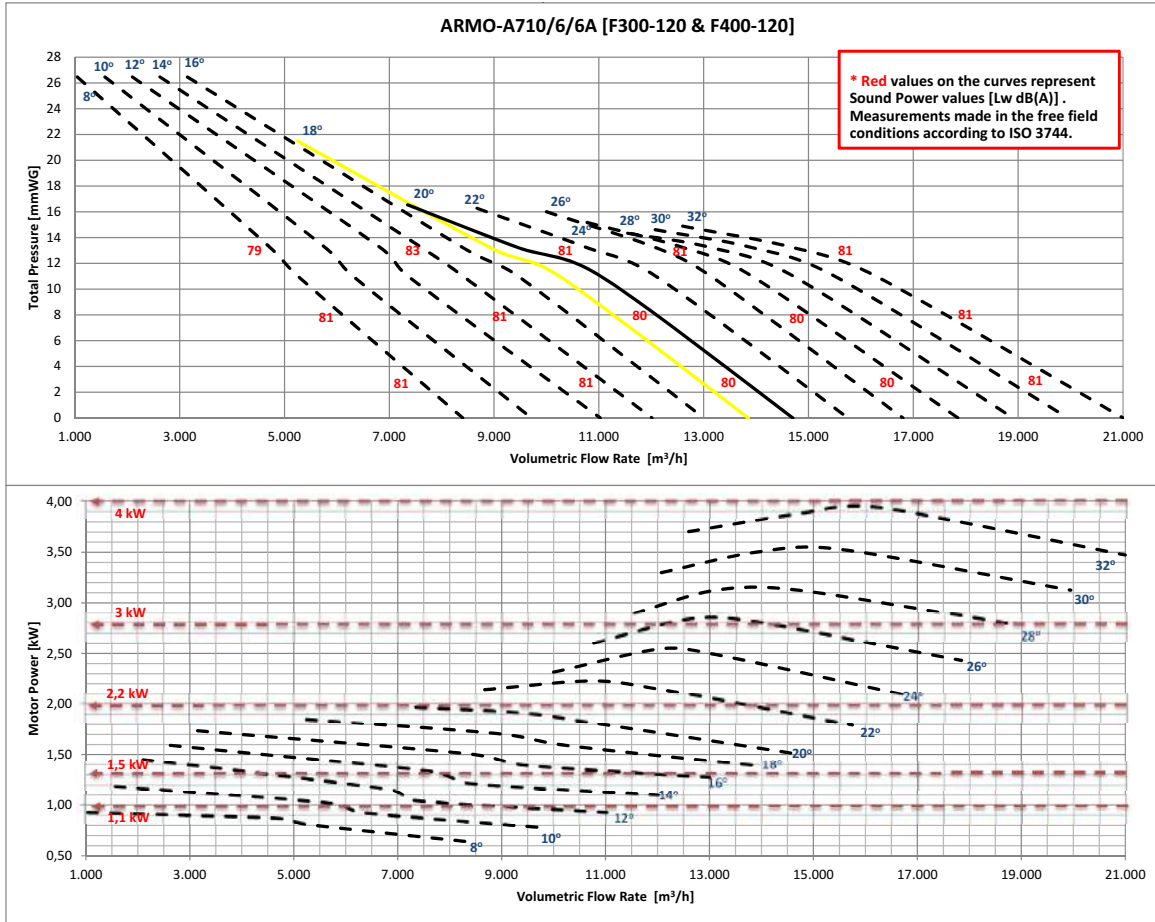

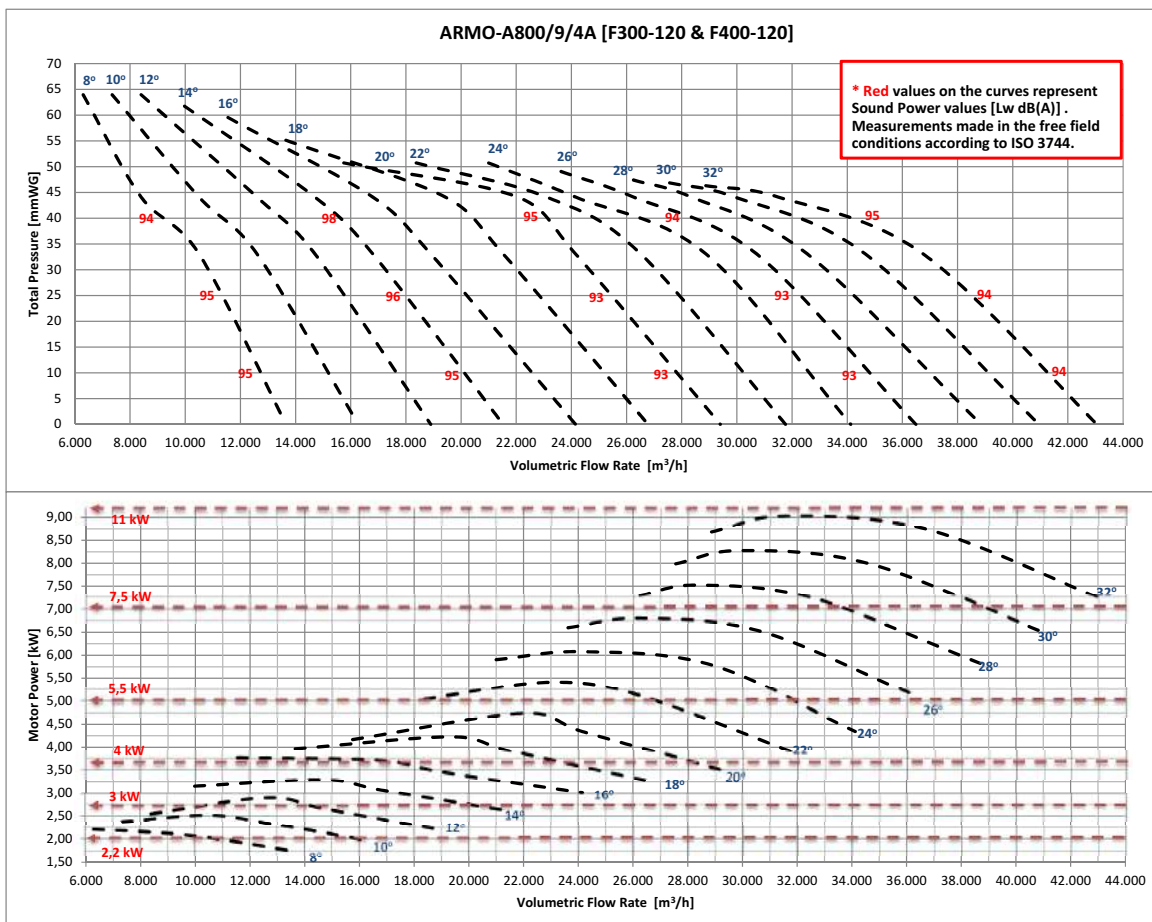
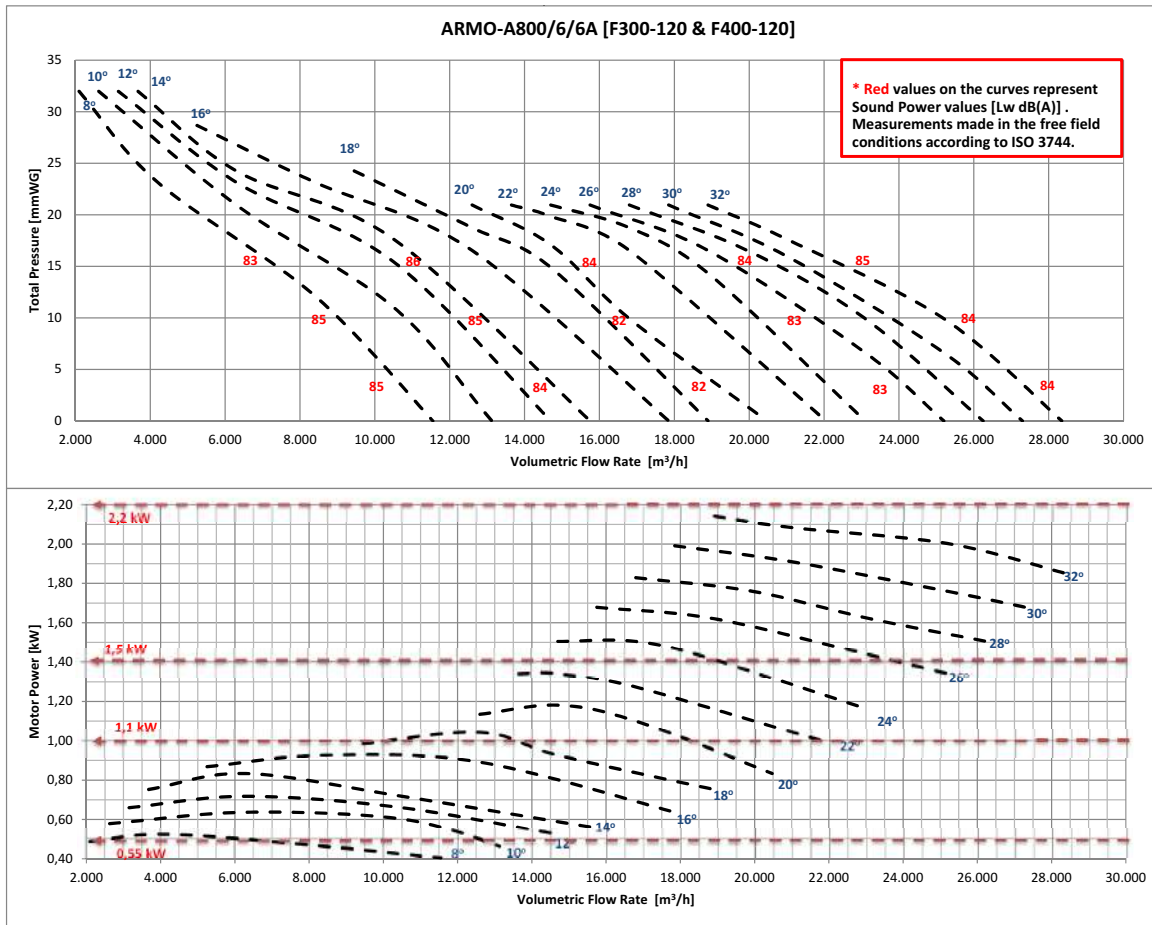

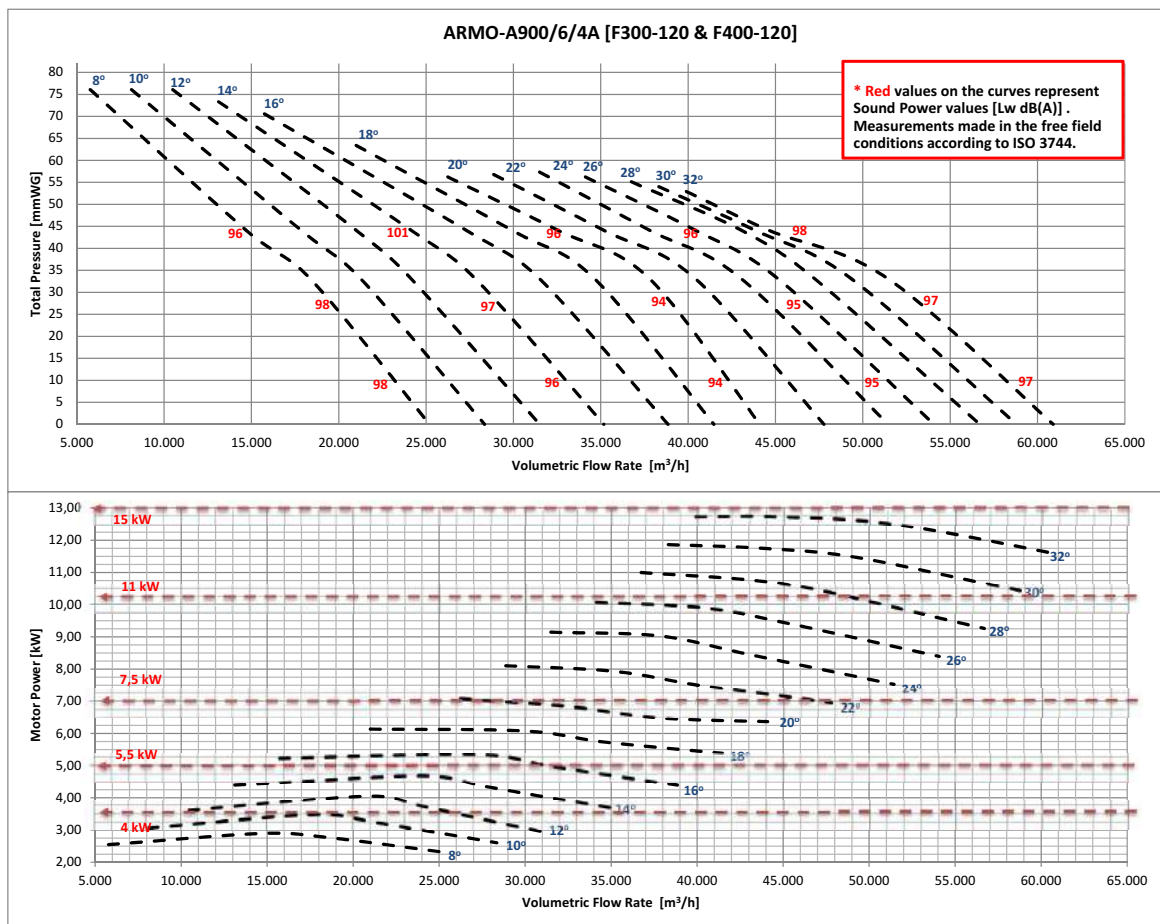
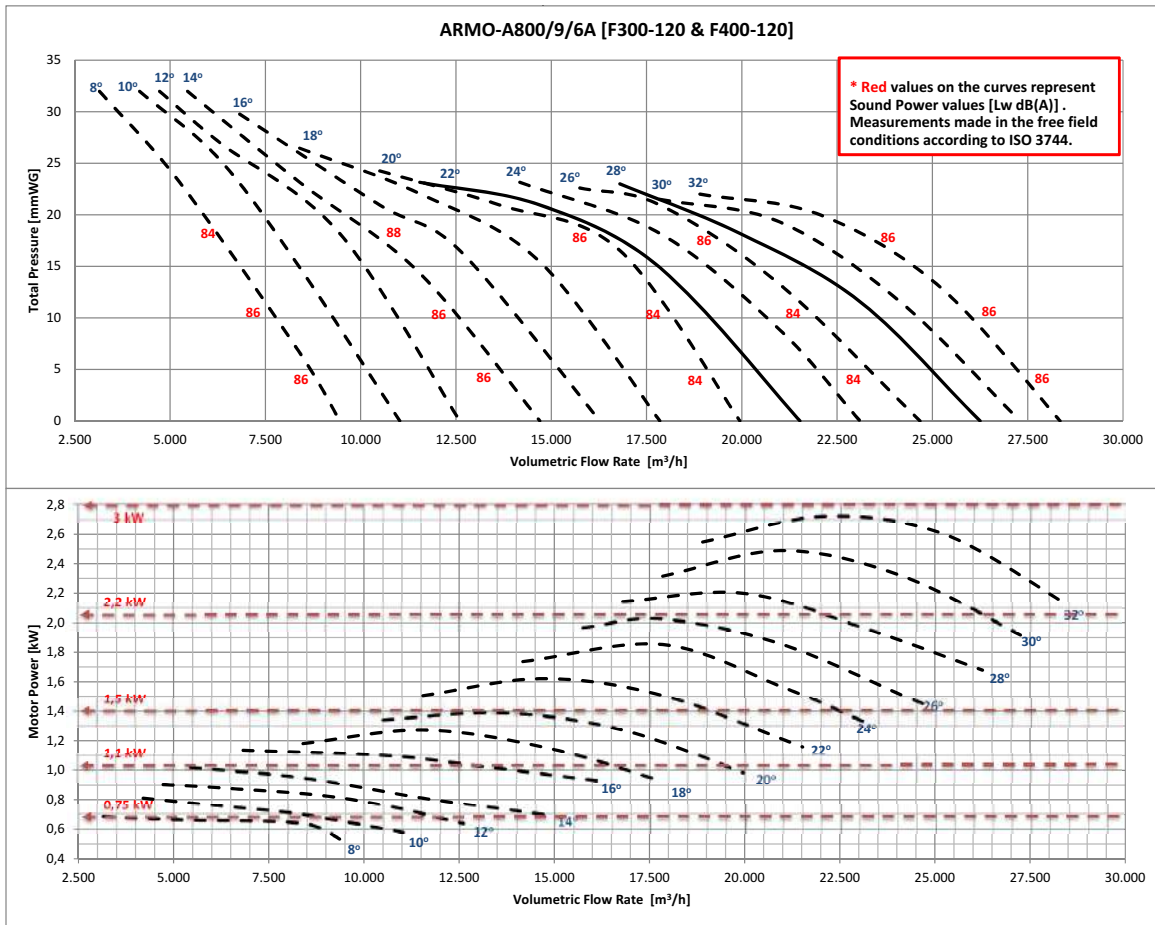

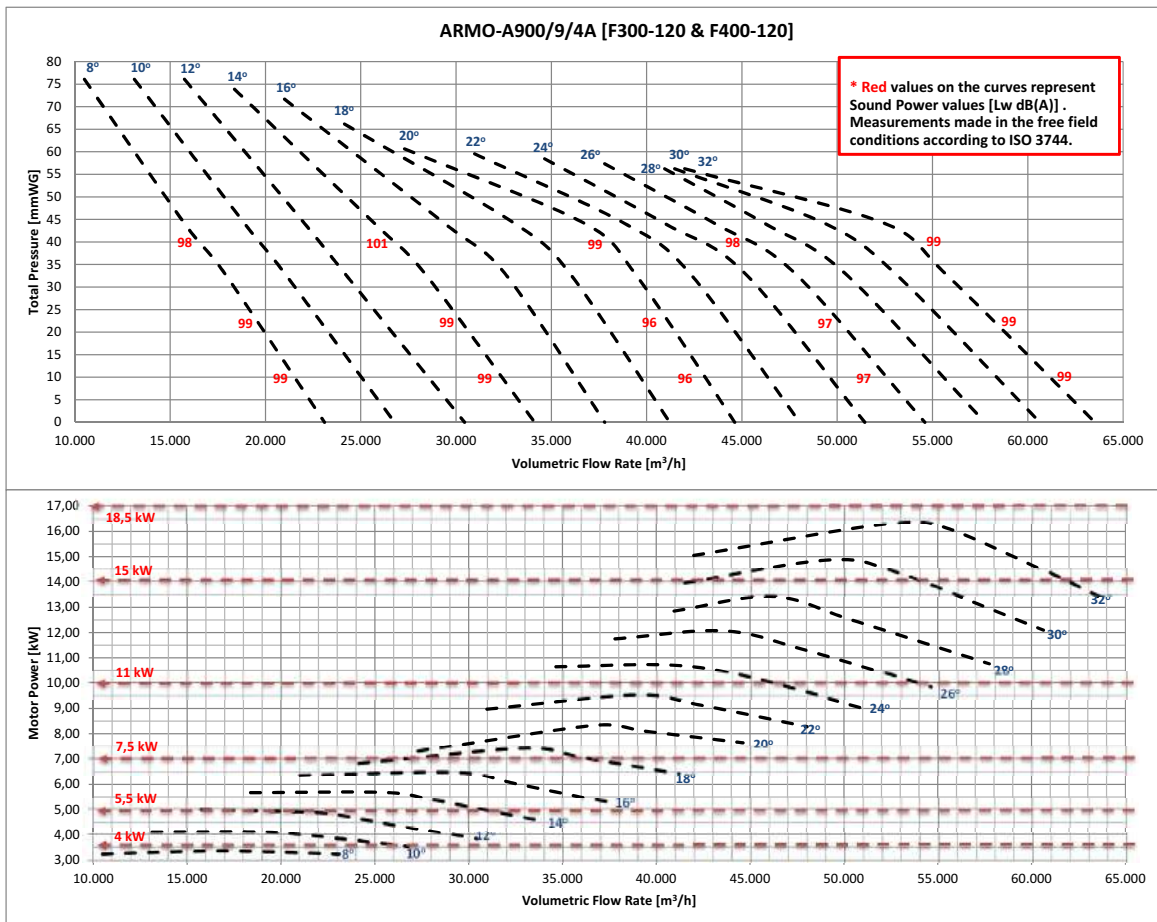
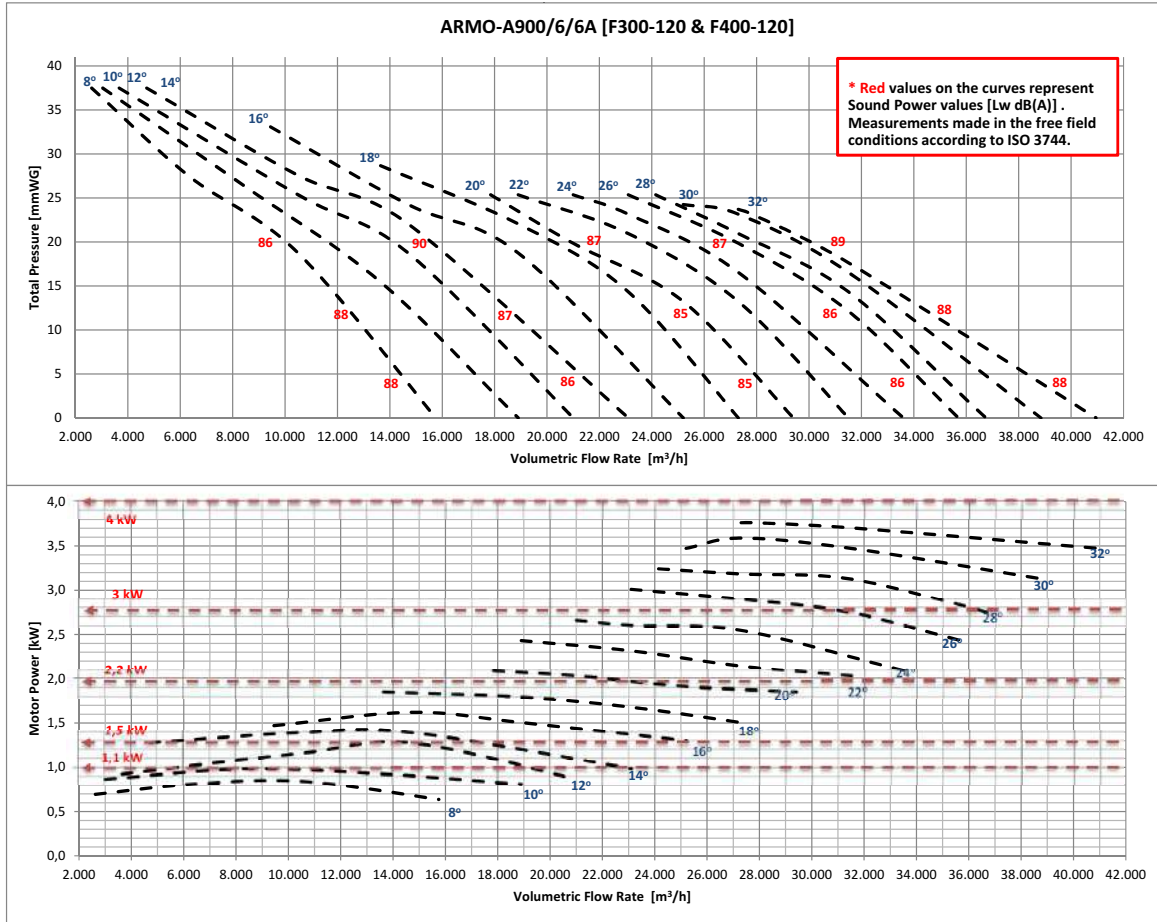

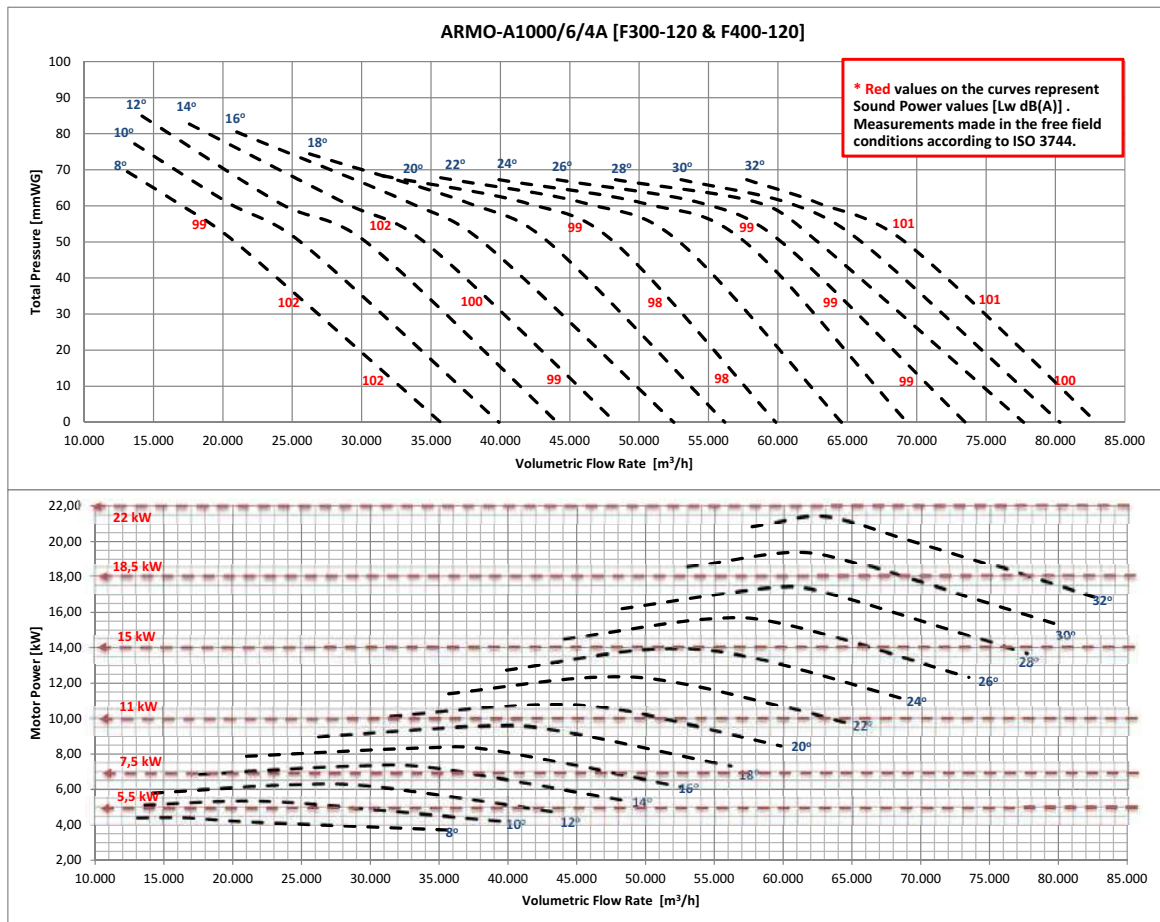
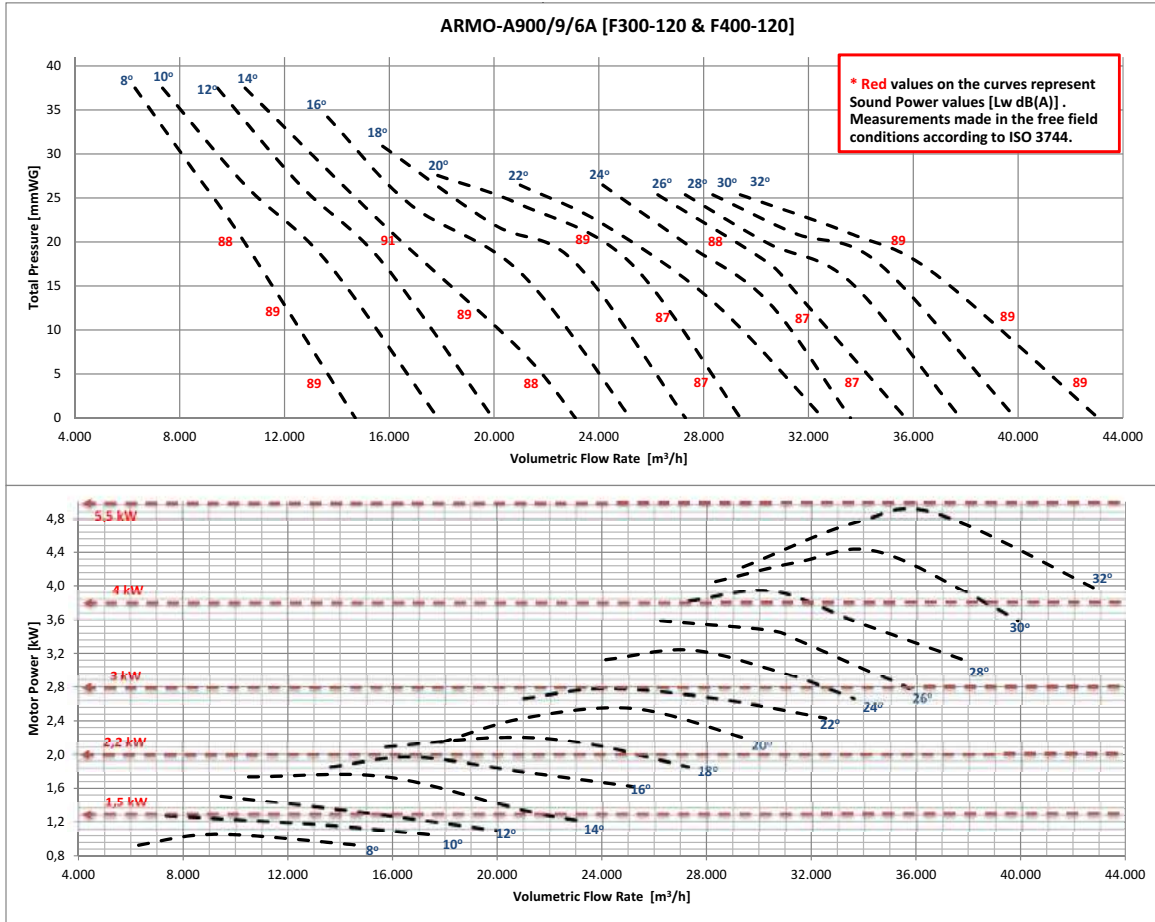

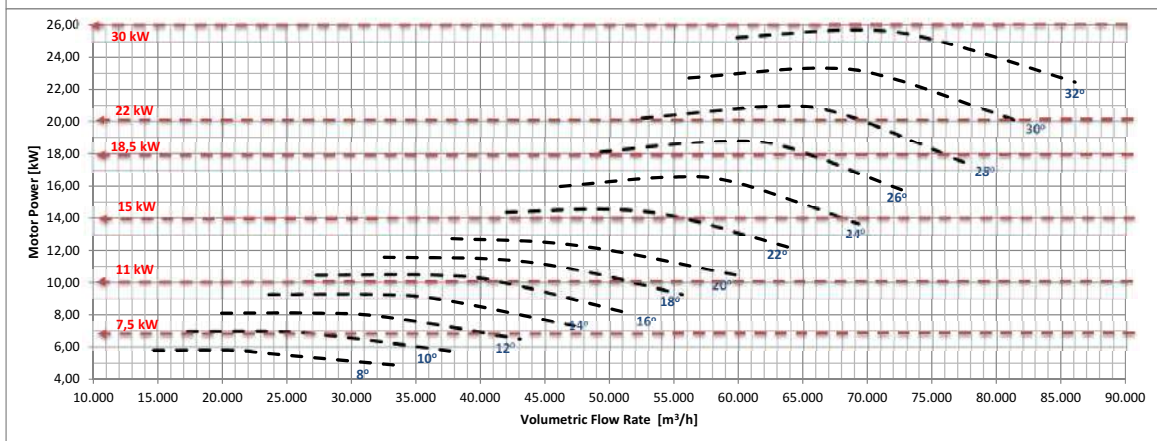
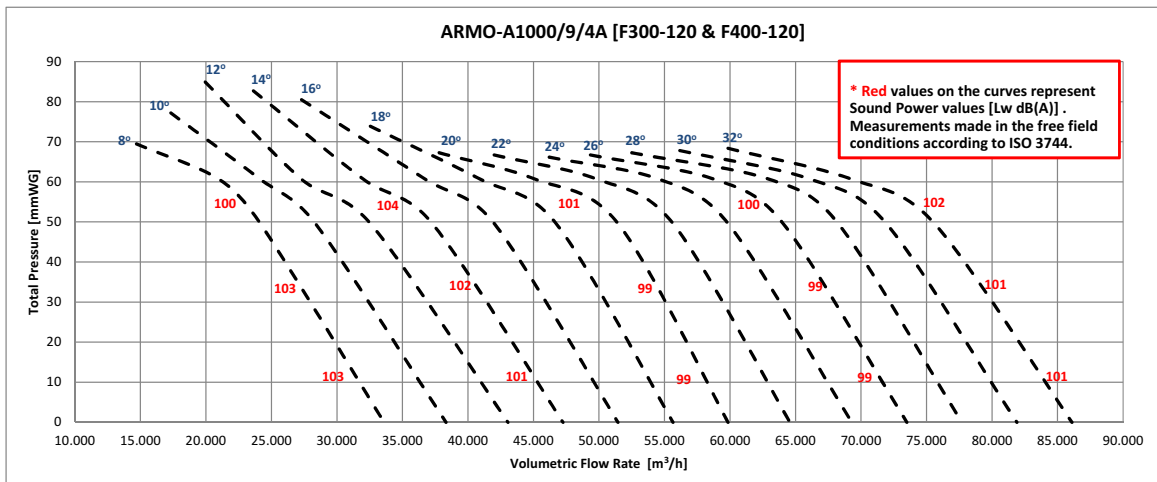
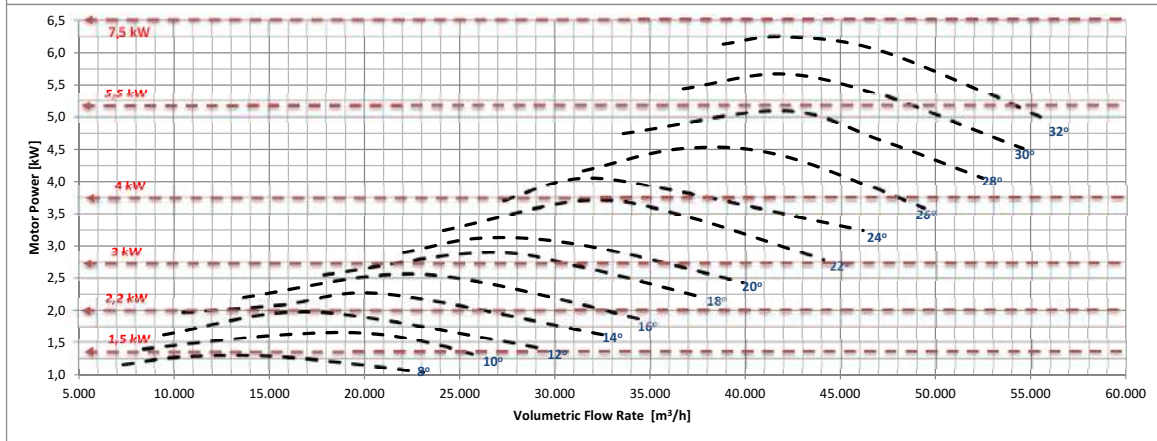
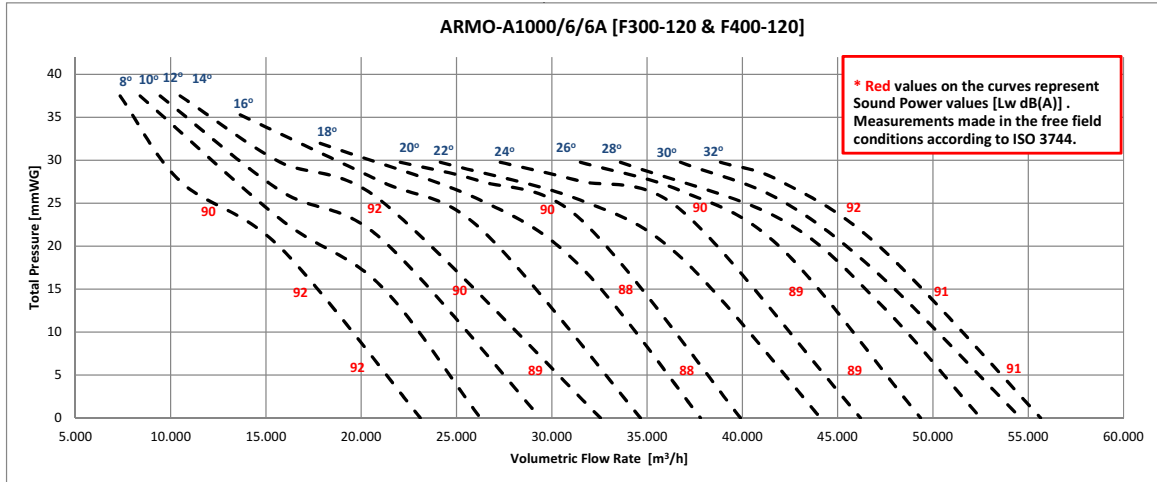

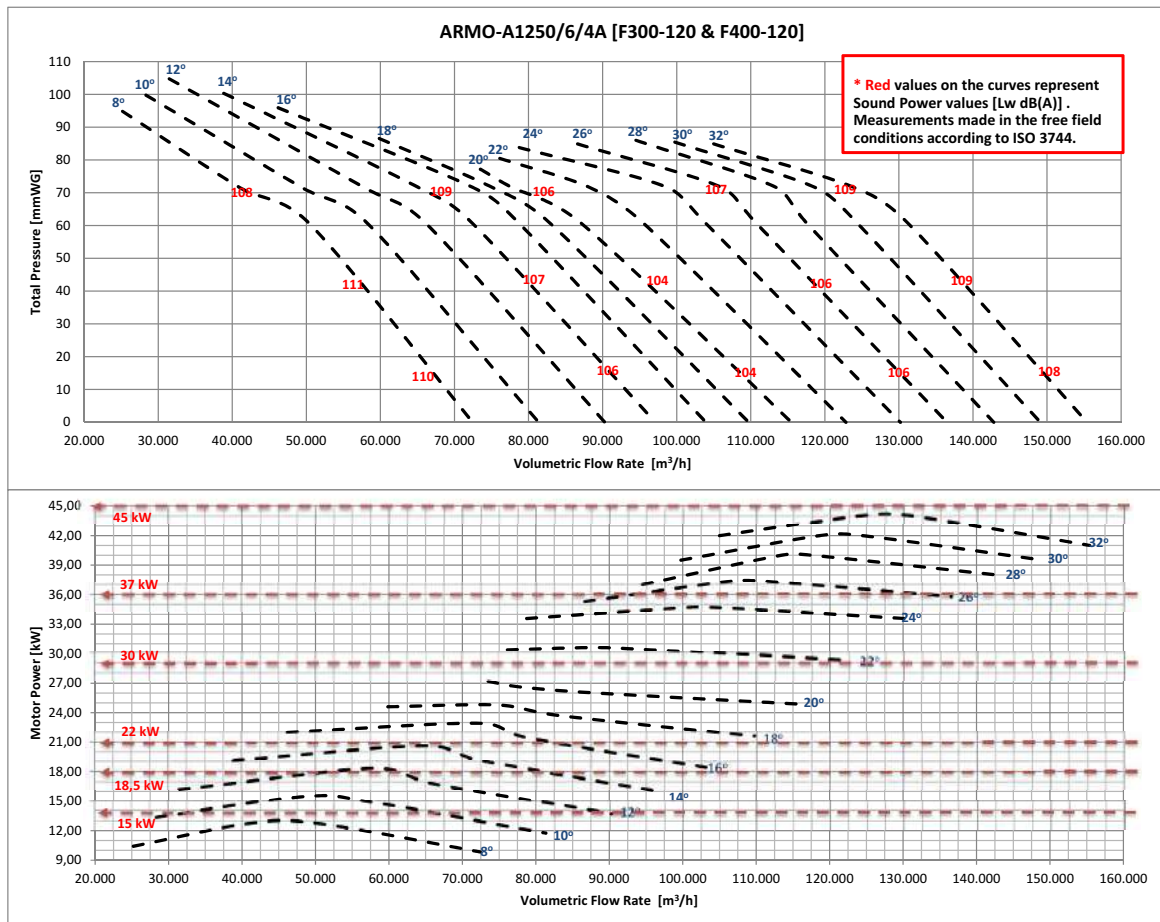
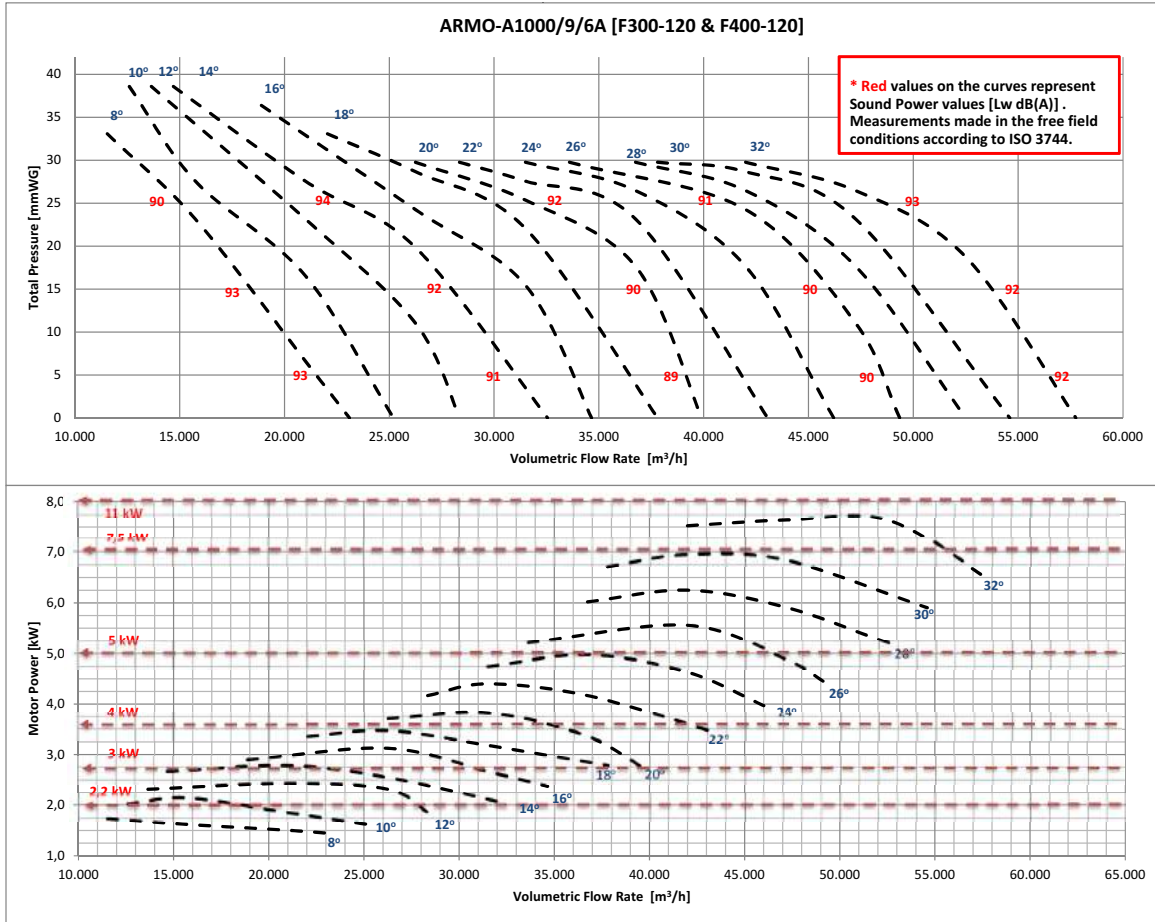

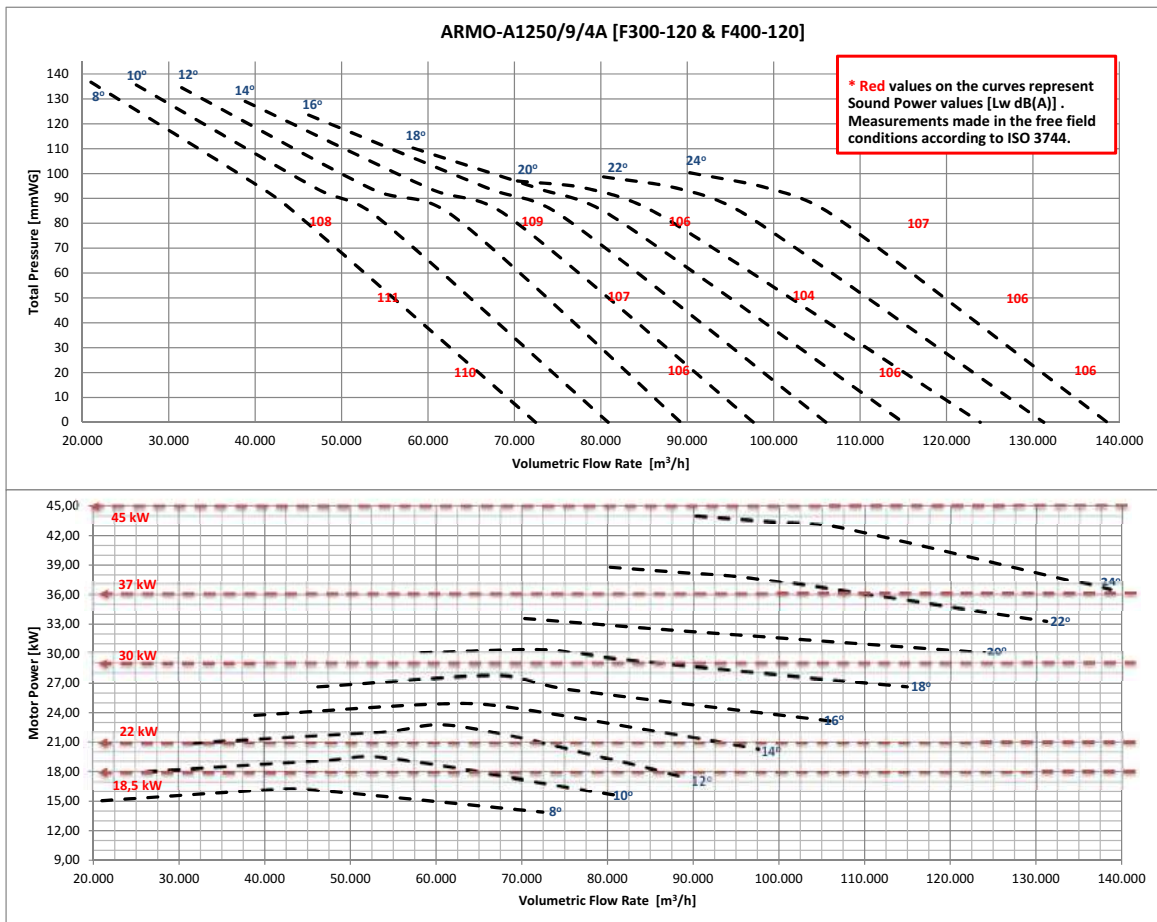
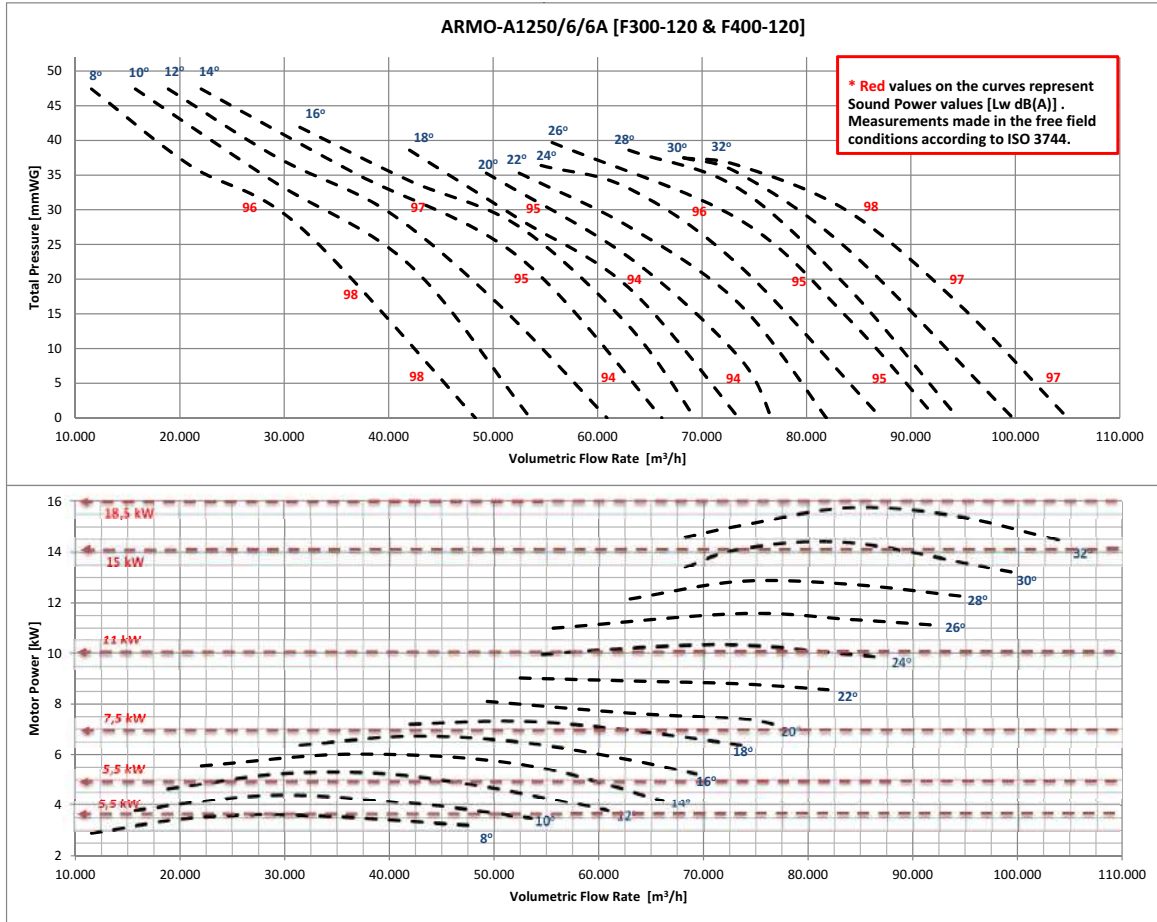

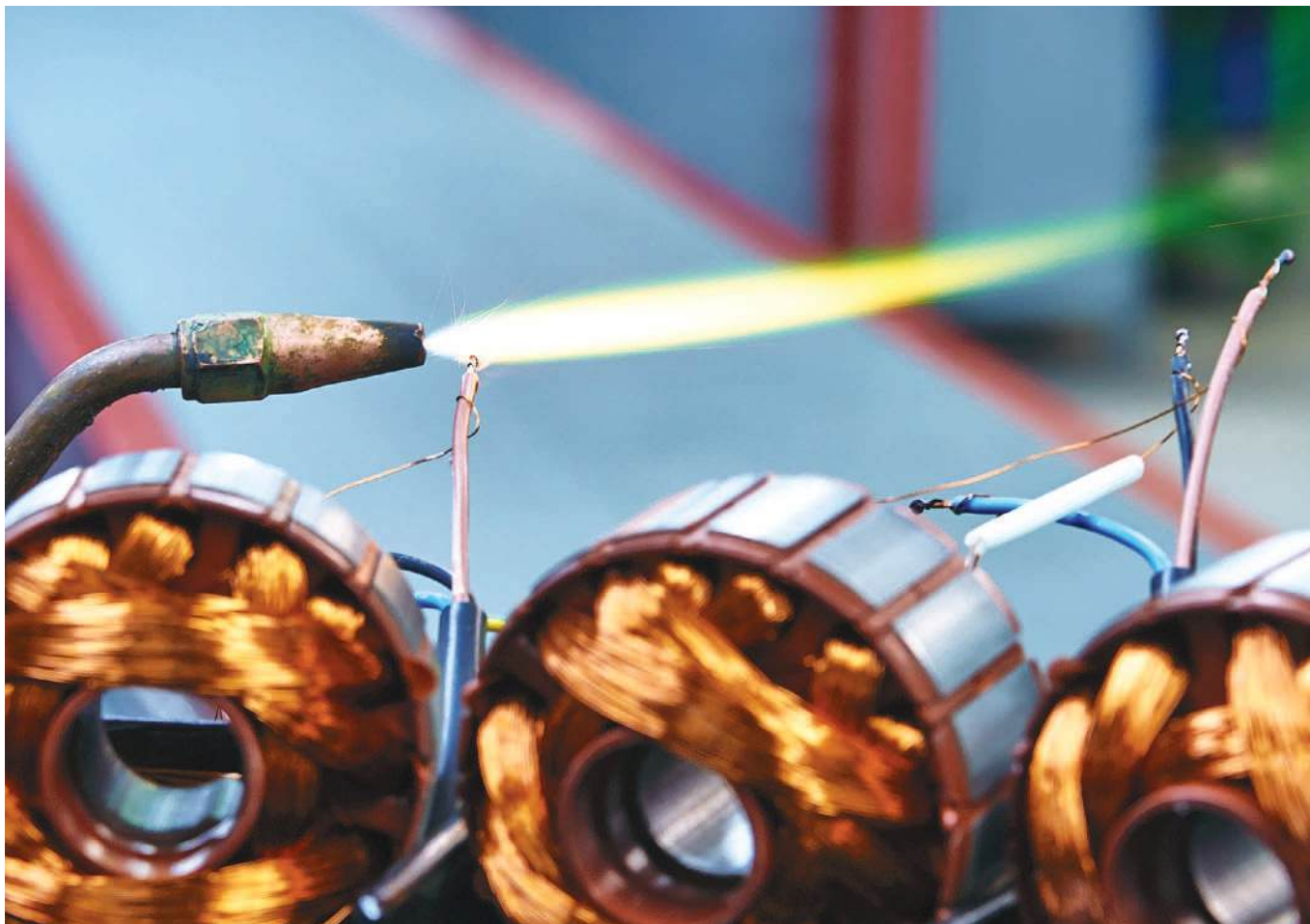
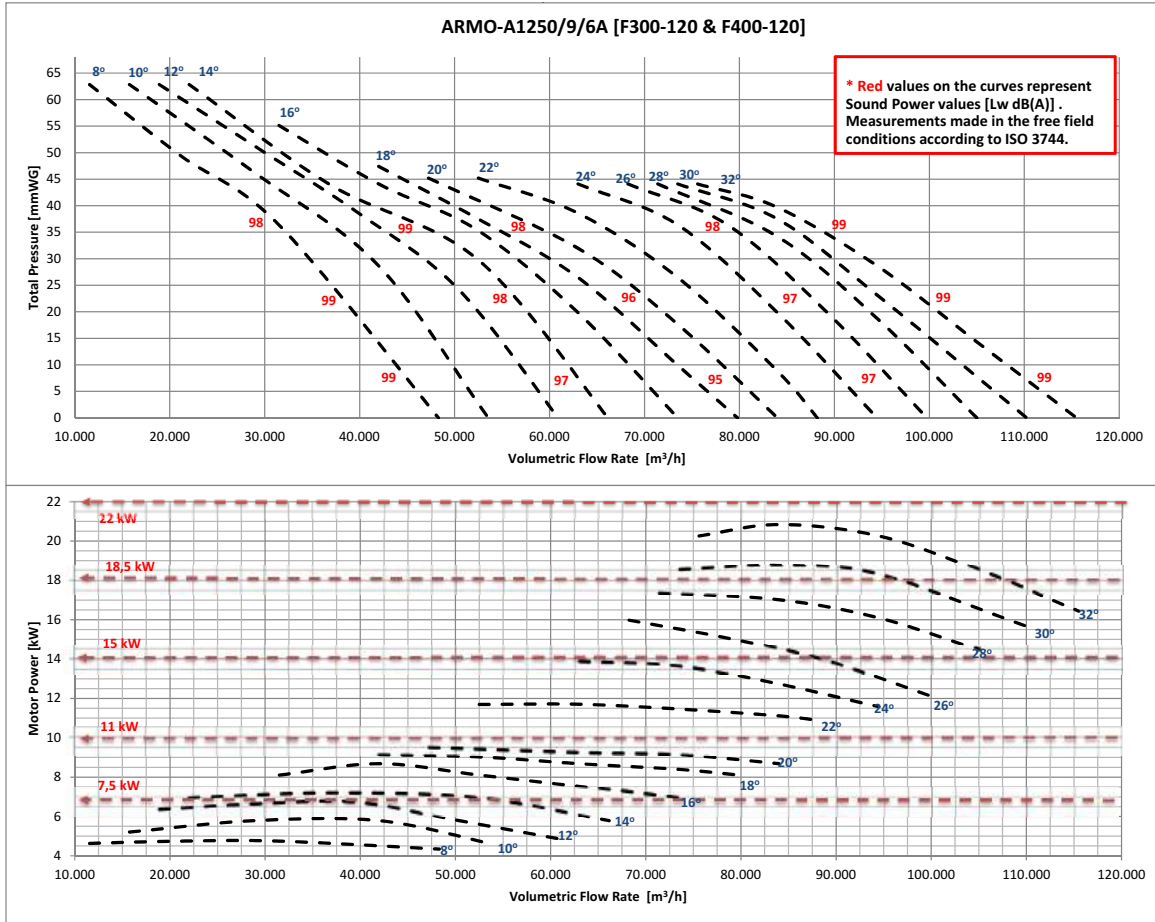





ARMO-C

SMOKE AND HEAT EXHAUST FANS / Cabinet



Box Axial fans are used in pressurization fan, fresh air fan and smoke exhaust fan applications. The box is fire resistant and designed according to the noise standard. Smoke evacuation fans are fire resistant.

- The fan part of the fan is dynamically balanced according to ISO 1940 and there is no eccentricity during the operation of the fan.

General Features

- It has EN 12101-3 and Ce certificates.
- 2 hours continuous operation at 400 C and 300C
- There is a wide product range from 400 mm to 1250 mm.

Body Features

- Fan body is steel sheet. Body is hot dip galvanized and corrosion resistant.
- It has short type body and long type body types.

Rotor Features

- Fire resistant aluminum alloy casting blades and fan hub.
- has the ability to work one-way and two-way. The blades are specially designed according to each direction type.
- There is no aerodynamic loss in the case of reversible wing type operation.
- Wings are airfoil and provide high aerodynamic performance in both unidirectional and bidirectional vanes.
- Wing angles are adjustable. In this way, smoke discharge fans can be demanded at different flow rates and pressures.

Motor Features

- Offers 2.4 and 6-pole motors
- The motors are IP 55 class and Class-H insulated.
- All electric motor models are approved for continuous operation (S1) and Emergency operation (S2).

Ease of Maintenance

A maintenance cover is provided to ensure easy maintenance.

Usage Areas

Stair pressurization fan, fresh air fan, smoke is used as exhaust fan.

Technical Drawing and Tables

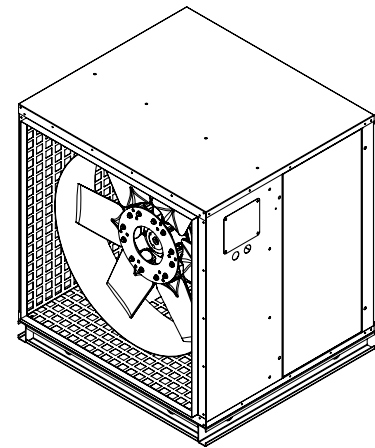
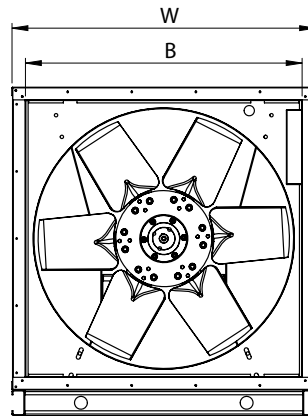
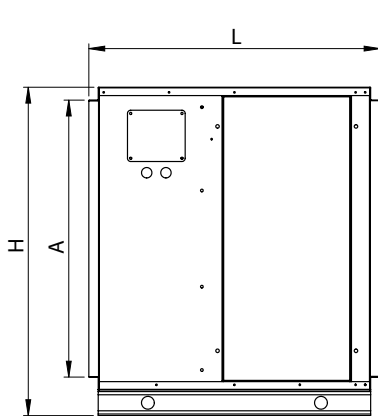

TYPE	L	W	H	A	B
ARMO-C 400	592	568	640	490	490
ARMO-C 450	592	568	640	490	490
ARMO-C 500	592	620	686	536	536
ARMO-C 560	745	707	775	624	624
ARMO-C 630	745	777	845	694	694
ARMO-C 710	910	857	925	774	774
ARMO-C 800	910	950	1025	865	865
ARMO-C 900	1065	1050	1125	965	965
ARMO-C 1000	1065	1150	1250	1069	1069
ARMO-C 1250	1065	1400	1500	1319	1319

Dimensions are in (mm)



2 POLE						
TYPE	SPEED	DIAMETER	POWER	CURRENT	AIR FLOW	WING ANGLE
	r.p.m	mm	kW	230V - 400V	m ³ /h	
ARMO-C / 400-6 / 0,75 - 2A	2900	400	0,75	1,6	5250	16°
ARMO-C / 400-6 / 1,1 - 2A	2900	400	1,1	2,3	6904	22°
ARMO-C / 400-6 / 1,5 - 2A	2900	400	1,5	3,4	8978	30°
ARMO-C / 400-6 / 2,2 - 2A	2900	400	2,2	4,48	9975	34°
ARMO-C / 450-6 / 1,1 - 2A	2900	450	1,1	2,3	6248	10°
ARMO-C / 450-6 / 1,5 - 2A	2900	450	1,5	3,4	8610	16°
ARMO-C / 450-6 / 2,2 - 2A	2900	450	2,2	4,48	11970	24°
ARMO-C / 450-6 / 3 - 2A	2900	450	3	6	13545	28°
ARMO-C / 500-6 / 2,2 - 2A	2900	500	2,2	4,48	11000	14°
ARMO-C / 500-6 / 3 - 2A	2900	500	3	6	14595	20°
ARMO-C / 500-6 / 4 - 2A	2900	500	4	7,4	17325	26°
ARMO-C / 500-6 / 5,5 - 2A	2900	500	5,5	11	18375	28°
ARMO-C / 560-6 / 4 - 2A	2900	560	4	7,4	17850	14°
ARMO-C / 560-6 / 5,5 - 2A	2900	560	5,5	11	22313	20°
ARMO-C / 560-6 / 7,5 - 2A	2800	560	7,5	13,6	25725	24°
ARMO-C / 630-6 / 5,5 - 2A	2900	630	5,5	11	20475	10°
ARMO-C / 630-6 / 7,5 - 2A	2800	630	7,5	13,6	27300	16°

4 POLE TYPE	SPEED	DIAMETER	POWER	CURRENT	AIR FLOW	WING ANGLE
	r.p.m	mm	kW	230V - 400V	m ³ /h	
ARMO-C / 500-6 / 0,55 - 4A	1415	500	0,55	1,6	8715	26
ARMO-C / 500-6 / 0,75 - 4A	1350	500	0,75	2,1	10290	32
ARMO-C / 500-6 / 1,1 - 4A	1400	500	1,1	2,6	12600	38
ARMO-C / 560-6 / 0,55 - 4A	1415	560	0,55	1,6	9870	16
ARMO-C / 560-6 / 0,75 - 4A	1350	560	0,75	2,1	12075	22
ARMO-C / 560-6 / 1,1 - 4A	1400	560	1,1	2,6	13860	26
ARMO-C / 560-6 / 1,5 - 4A	1405	560	1,5	3,5	15750	32
ARMO-C / 560-6 / 2,2 - 4A	1410	560	2,2	5	17850	38
ARMO-C / 630-6 / 0,75 - 4A	1350	630	0,75	2,1	10605	10
ARMO-C / 630-6 / 1,1 - 4A	1400	630	1,1	2,6	16275	20
ARMO-C / 630-6 / 1,5 - 4A	1405	630	1,5	3,5	18375	24
ARMO-C / 630-6 / 2,2 - 4A	1410	630	2,2	5	21525	30
ARMO-C / 630-6 / 3 - 4A	1410	630	3	6,6	24150	36
ARMO-C / 630-6 / 4 - 4A	1500	630	4	8,2	25200	38
ARMO-C / 710-3 / 0,75 - 4A	1350	710	0,75	2,1	14175	10
ARMO-C / 710-3 / 1,1 - 4A	1400	710	1,1	2,6	18375	16
ARMO-C / 710-3 / 1,5 - 4A	1405	710	1,5	3,5	21000	20
ARMO-C / 710-3 / 2,2 - 4A	1410	710	2,2	5	24413	26
ARMO-C / 710-3 / 3 - 4A	1410	710	3	6,6	27825	32
ARMO-C / 710-6 / 1,1 - 4A	1400	710	1,1	2,6	16275	12
ARMO-C / 710-6 / 1,5 - 4A	1405	710	1,5	3,5	20475	18
ARMO-C / 710-6 / 2,2 - 4A	1410	710	2,2	5	23625	22
ARMO-C / 710-6 / 3 - 4A	1410	710	3	6,6	28350	28
ARMO-C / 710-6 / 4 - 4A	1415	710	4	8,2	31500	32
ARMO-C / 800-6 / 2,2 - 4A	1410	800	2,2	5	24150	14
ARMO-C / 800-6 / 3 - 4A	1410	800	3	6,6	30450	20
ARMO-C / 800-6 / 4 - 4A	1415	800	4	8,2	32550	22
ARMO-C / 800-6 / 5,5 - 4A	1430	800	5,5	11,2	38850	28
ARMO-C / 800-6 / 7,5 - 4A	1440	800	7,5	15,4	42525	32
ARMO-C / 800-9 / 2,2 - 4A	1410	800	2,2	5	16275	10
ARMO-C / 800-9 / 3 - 4A	1410	800	3	6,6	21525	14
ARMO-C / 800-9 / 4 - 4A	1415	800	4	8,2	29400	20
ARMO-C / 800-9 / 5,5 - 4A	1430	800	5,5	11,2	36488	26
ARMO-C / 800-9 / 7,5 - 4A	1440	800	7,5	15,4	40950	30
ARMO-C / 800-9 / 11 - 4A	1450	800	11	21	43050	32
ARMO-C / 900-6 / 4 - 4A	1415	900	4	8,2	31500	12
ARMO-C / 900-6 / 5,5 - 4A	1430	900	5,5	11,2	38850	16
ARMO-C / 900-6 / 7,5 - 4A	1440	900	7,5	15,4	47775	22
ARMO-C / 900-6 / 11 - 4A	1450	900	11	21	56700	28
ARMO-C / 900-6 / 15 - 4A	1450	900	15	29,3	60900	32
ARMO-C / 900-9 / 4 - 4A	1415	900	4	8,2	26775	10
ARMO-C / 900-9 / 5,5 - 4A	1430	900	5,5	11,2	34125	14
ARMO-C / 900-9 / 7,5 - 4A	1440	900	7,5	15,4	41213	18
ARMO-C / 900-9 / 11 - 4A	1450	900	11	21	54600	26
ARMO-C / 900-9 / 15 - 4A	1450	900	15	29,3	63525	32
ARMO-C / 1000-6 / 5,5 - 4A	1430	1000	5,5	11,2	38850	12
ARMO-C / 1000-6 / 7,5 - 4A	1440	1000	7,5	15,4	47775	18
ARMO-C / 1000-6 / 11 - 4A	1450	1000	11	21	56700	22
ARMO-C / 1000-6 / 15 - 4A	1450	1000	15	29,3	60900	28
ARMO-C / 1000-6 / 18,5 - 4A	1455	1000	18,5	34,5	56700	32
ARMO-C / 1000-9 / 7,5 - 4A	1440	1000	7,5	15,4	43050	12
ARMO-C / 1000-9 / 11 - 4A	1450	1000	11	21	55650	18
ARMO-C / 1000-9 / 15 - 4A	1450	1000	15	29,3	69300	24
ARMO-C / 1000-9 / 18,5 - 4A	1455	1000	18,5	34,5	77700	28
ARMO-C / 1000-9 / 22 - 4A	1460	1000	22	42,5	81900	30
ARMO-C / 1000-9 / 30 - 4A	1460	1000	30	55	86100	32
ARMO-C / 1250-6 / 15 - 4A	1450	1250	15	29,3	90300	12
ARMO-C / 1250-6 / 18,5 - 4A	1455	1250	18,5	34,5	103950	16
ARMO-C / 1250-6 / 22 - 4A	1460	1250	22	42,5	109725	18
ARMO-C / 1250-6 / 30 - 4A	1460	1250	30	55	122850	22
ARMO-C / 1250-6 / 37 - 4A	1470	1250	37	67	136500	26
ARMO-C / 1250-6 / 45 - 4A	1475	1250	45	80	155400	32
ARMO-C / 1250-9 / 18,5 - 4A	1455	1250	18,5	34,5	89250	12
ARMO-C / 1250-9 / 22 - 4A	1460	1250	22	42,5	97650	14
ARMO-C / 1250-9 / 30 - 4A	1460	1250	30	55	114975	18
ARMO-C / 1250-9 / 37 - 4A	1470	1250	37	67	131250	22
ARMO-C / 1250-9 / 45 - 4A	1475	1250	45	80	138600	24

6 POLE TYPE	SPEED	DIAMETER	POWER	CURRENT	AIR FLOW	WING ANGLE
	r.p.m	mm	kW	230V - 400V	m ³ /h	
ARMO-C / 500-6 / 0,37 - 6A	900	500	0,37	1,1	8400	38
ARMO-C / 560-6 / 0,37 - 6A	900	560	0,37	1,1	10500	32
ARMO-C / 560-6 / 0,55 - 6A	930	560	0,55	1,5	11760	38
ARMO-C / 630-6 / 0,37 - 6A	900	630	0,37	1,1	11576	22
ARMO-C / 630-6 / 0,55 - 6A	930	630	0,55	1,5	13650	28
ARMO-C / 630-6 / 0,75 - 6A	945	630	0,75	2	14963	32
ARMO-C / 630-6 / 1,1 - 6A	945	630	1,1	2,9	16800	38
ARMO-C / 710-3 / 0,37 - 6A	900	710	0,37	1,1	13125	18
ARMO-C / 710-3 / 0,55 - 6A	930	710	0,55	1,5	16538	26
ARMO-C / 710-3 / 0,75 - 6A	945	710	0,75	2	18900	32
ARMO-C / 710-6 / 1,1 - 6A	945	710	1,1	2,9	11025	12
ARMO-C / 710-6 / 1,5 - 6A	945	710	1,5	3,6	13000	16
ARMO-C / 710-6 / 2,2 - 6A	950	710	2,2	5,4	13750	22
ARMO-C / 710-6 / 3 - 6A	950	710	3	6,9	18900	28
ARMO-C / 710-6 / 4 - 6A	955	710	4	9	21000	32
ARMO-C / 800-6 / 0,55 - 6A	930	800	0,55		13125	10
ARMO-C / 800-6 / 1,1 - 6A	945	800	1,1	2,9	22050	22
ARMO-C / 800-6 / 1,5 - 6A	945	800	1,5	3,6	25200	26
ARMO-C / 800-6 / 2,2 - 6A	950	800	2,2	5,4	28350	32
ARMO-C / 800-9 / 0,75 - 6A	945	800	0,75	2	14700	14
ARMO-C / 800-9 / 1,1 - 6A	945	800	1,1	2,9	19950	20
ARMO-C / 800-9 / 1,5 - 6A	945	800	1,5	3,6	23100	24
ARMO-C / 800-9 / 2,2 - 6A	950	800	2,2	5,4	27300	30
ARMO-C / 800-9 / 3 - 6A	950	800	3	6,9	28350	32
ARMO-C / 900-6 / 1,1 - 6A	945	900	1,1	2,9	23100	14
ARMO-C / 900-6 / 1,5 - 6A	945	900	1,5	3,6	25200	16
ARMO-C / 900-6 / 2,2 - 6A	950	900	2,2	5,4	31500	22
ARMO-C / 900-6 / 3 - 6A	950	900	3	6,9	36750	28
ARMO-C / 900-6 / 4 - 6A	955	900	4	9	40950	32
ARMO-C / 900-9 / 1,5 - 6A	945	900	1,5	3,6	23100	14
ARMO-C / 900-9 / 2,2 - 6A	950	900	2,2	5,4	27300	20
ARMO-C / 900-9 / 3 - 6A	950	900	3	6,9	35700	24
ARMO-C / 900-9 / 4 - 6A	955	900	4	9	39900	30
ARMO-C / 900-9 / 5,5 - 6A	985	900	5,5	12,3	43050	32
ARMO-C / 1000-6 / 1,5 - 6A	945	1000	1,5	3,6	26250	10
ARMO-C / 1000-6 / 2,2 - 6A	950	1000	2,2	5,4	34650	16
ARMO-C / 1000-6 / 3 - 6A	950	1000	3	6,9	44100	22
ARMO-C / 1000-6 / 4 - 6A	955	1000	4	9	49350	26
ARMO-C / 1000-6 / 5,5 - 6A	985	1000	5,5	12,3	55650	32
ARMO-C / 1000-9 / 2,2 - 6A	950	1000	2,2	5,4	32550	14
ARMO-C / 1000-9 / 3 - 6A	950	1000	3	6,9	39900	20
ARMO-C / 1000-9 / 4 - 6A	955	1000	4	9	43050	22
ARMO-C / 1000-9 / 5,5 - 6A	985	1000	5,5	12,3	52500	28
ARMO-C / 1000-9 / 7,5 - 6A	960	1000	7,5	15	57750	32
ARMO-C / 1250-6 / 4 - 6A	955	1250	4	9	60900	12
ARMO-C / 1250-6 / 5,5 - 6A	985	1250	5,5	12,3	63300	16
ARMO-C / 1250-6 / 7,5 - 6A	960	1250	7,5	15	76650	20
ARMO-C / 1250-6 / 11 - 6A	960	1250	11	22	92400	26
ARMO-C / 1250-6 / 15 - 6A	965	1250	15	29	105000	32
ARMO-C / 1250-9 / 7,5 - 6A	960	1250	7,5	15	73500	16
ARMO-C / 1250-9 / 11 - 6A	960	1250	11	22	88200	22
ARMO-C / 1250-9 / 15 - 6A	965	1250	15	29	105000	28
ARMO-C / 1250-9 / 18,5 - 6A	970	1250	18,5	36,5	115500	32

Accessories



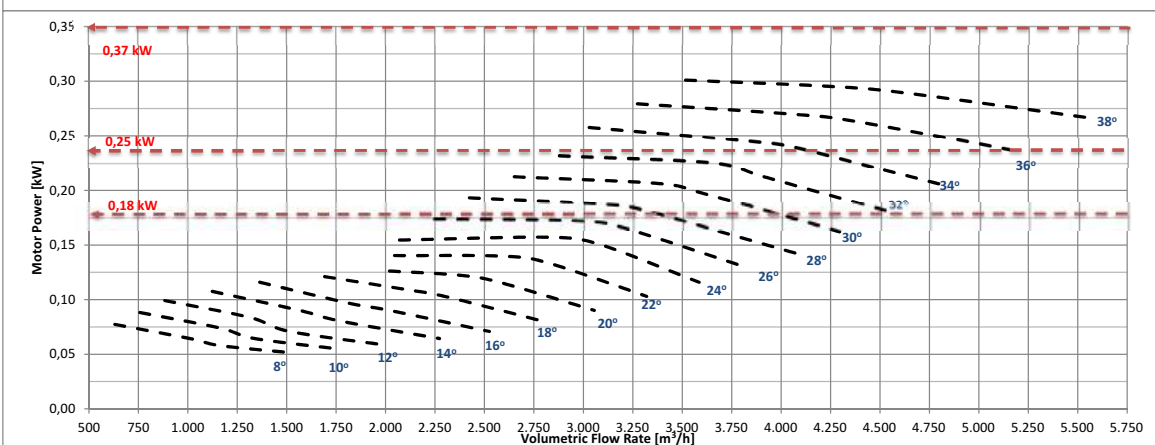
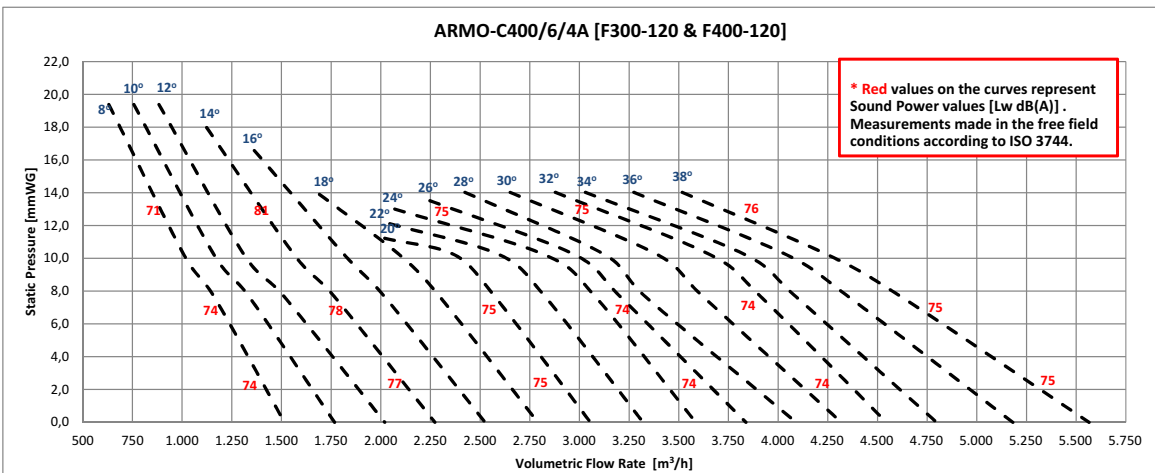
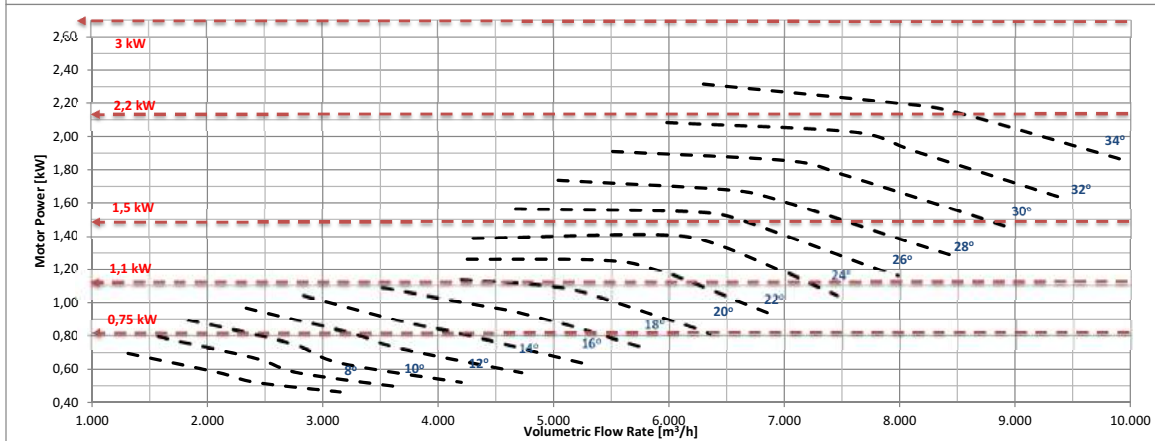
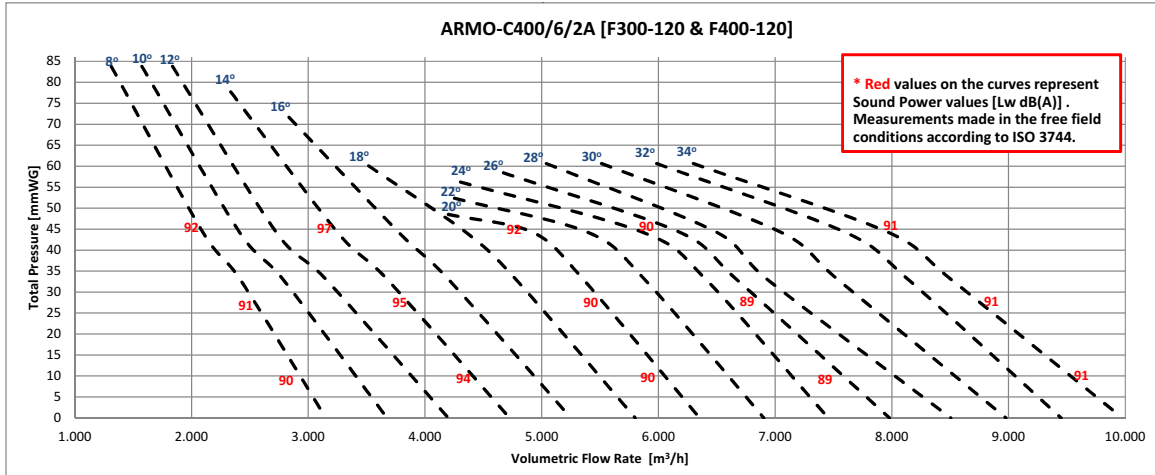

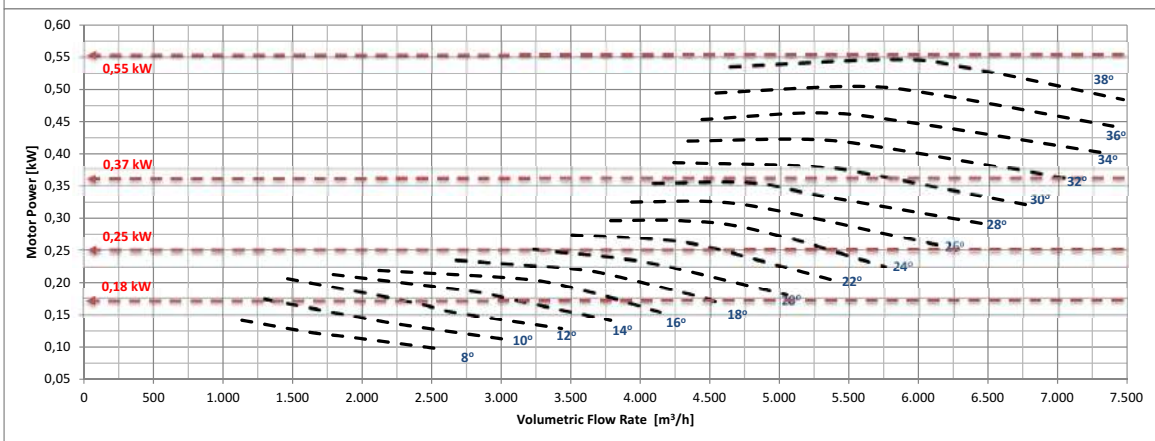
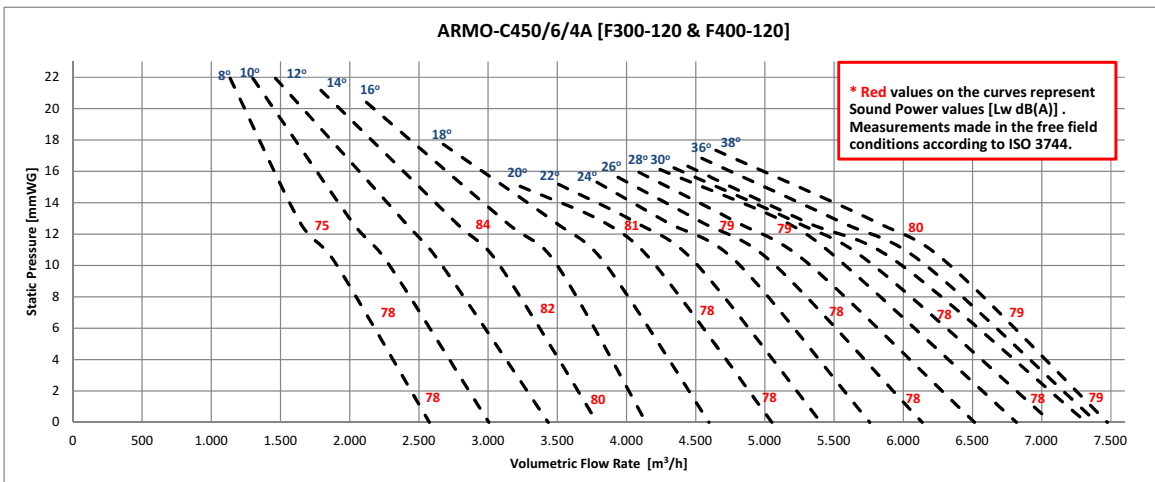
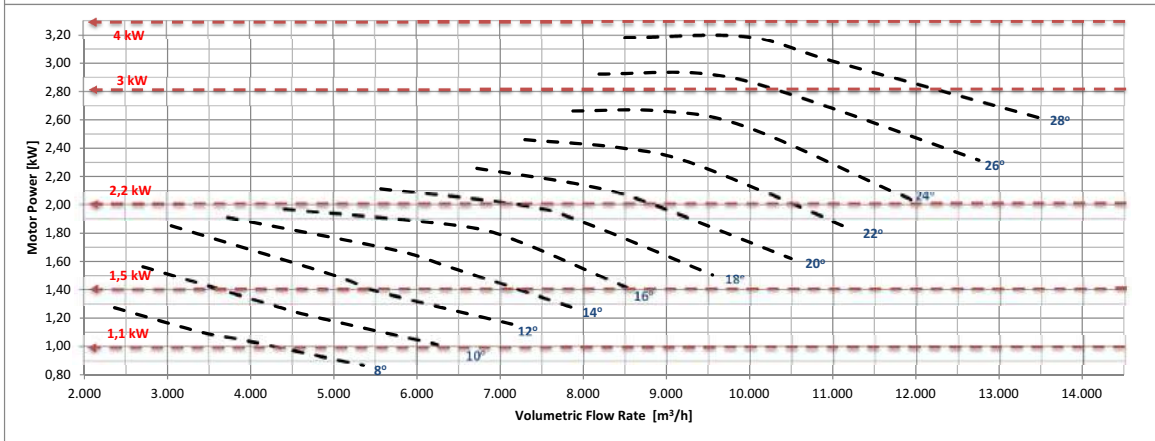
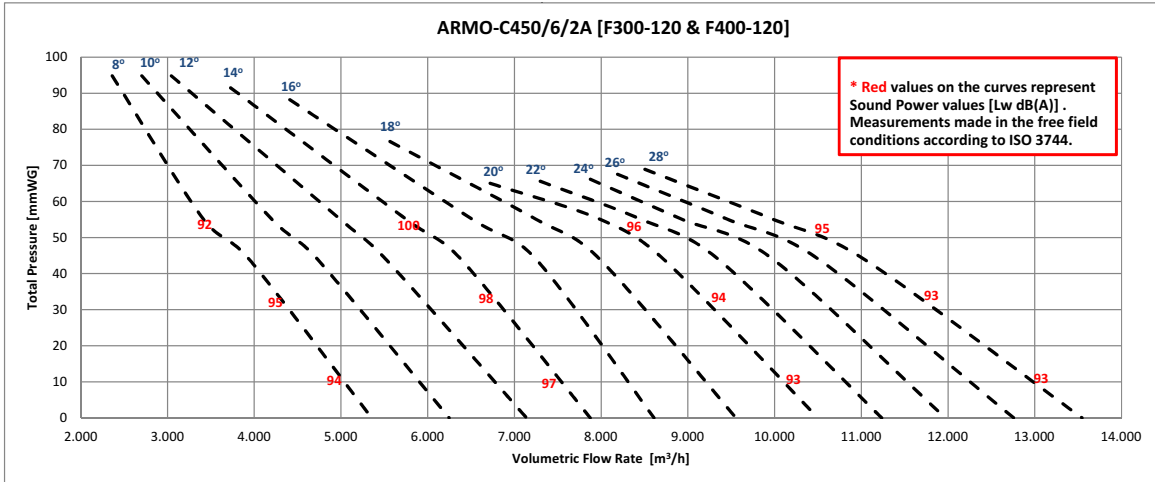

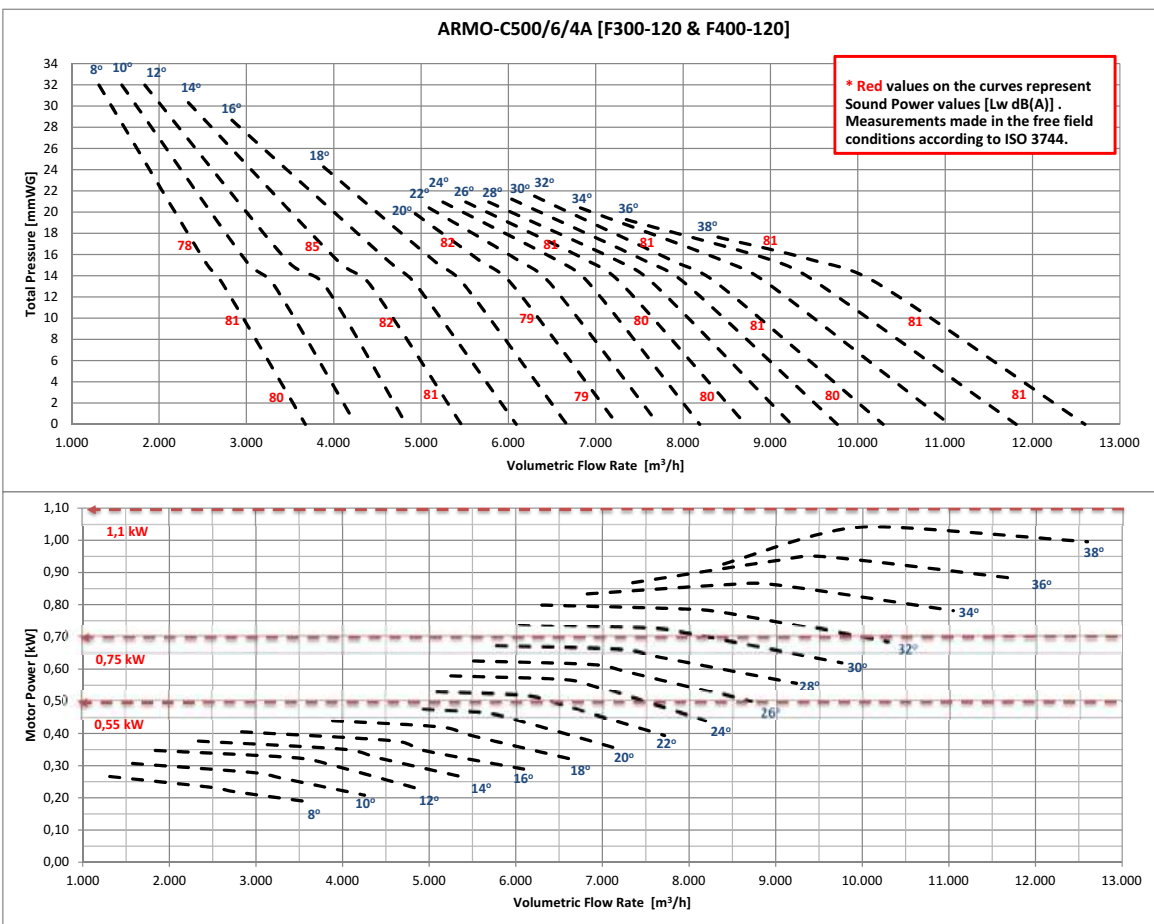
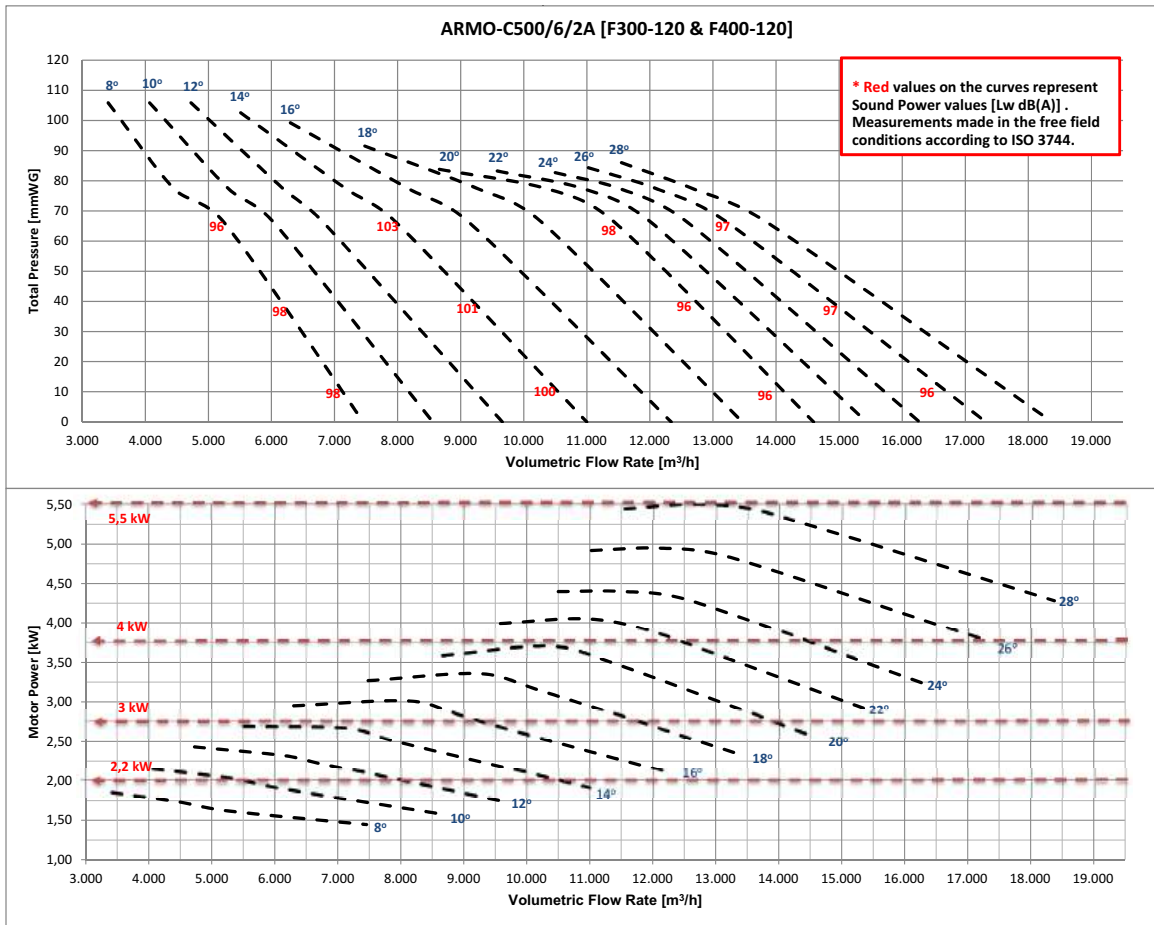

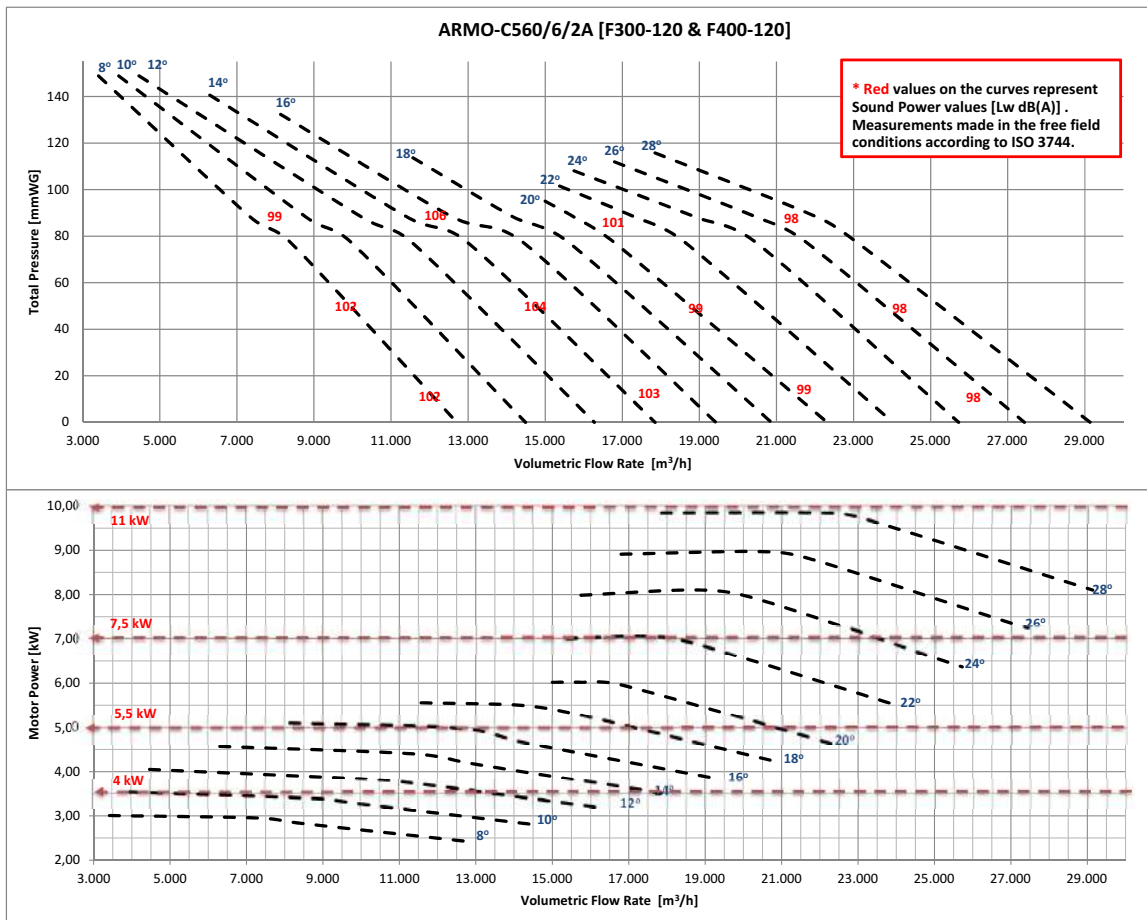
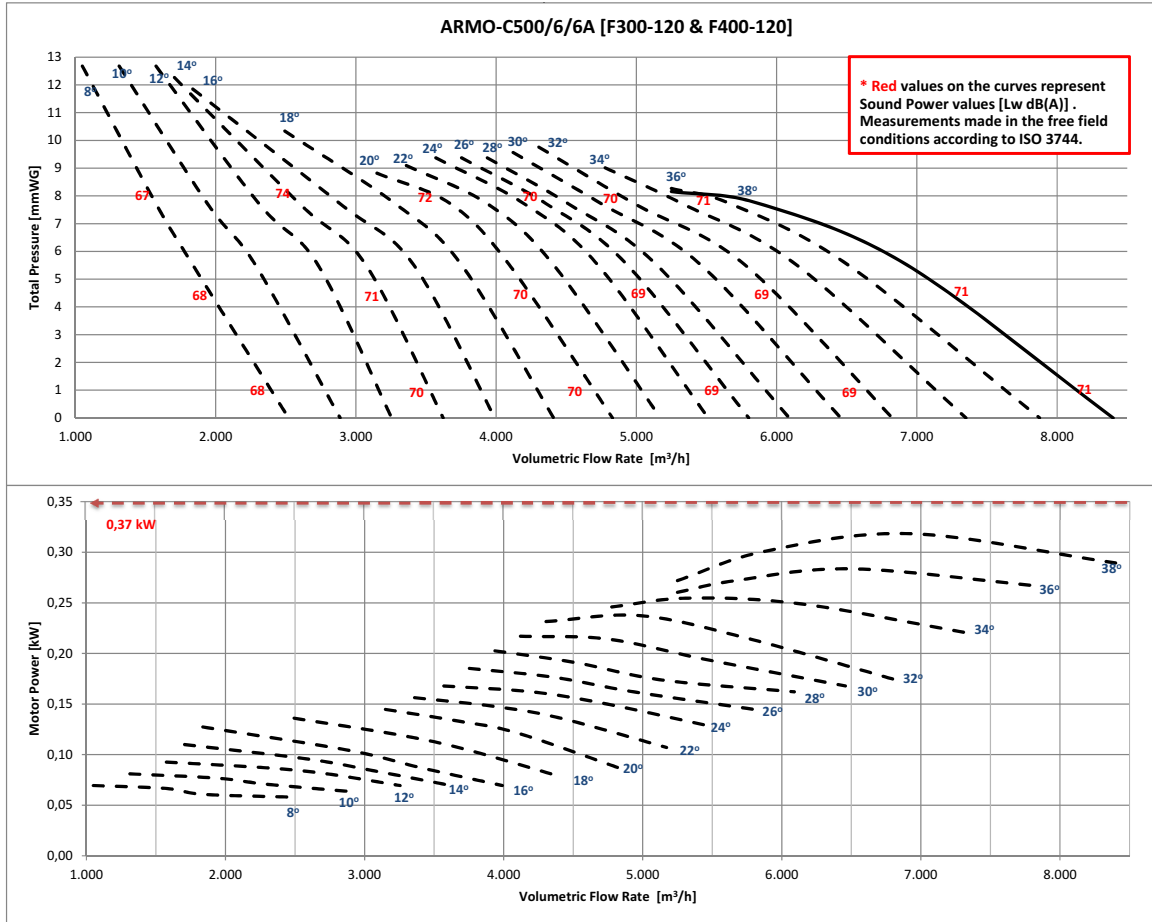

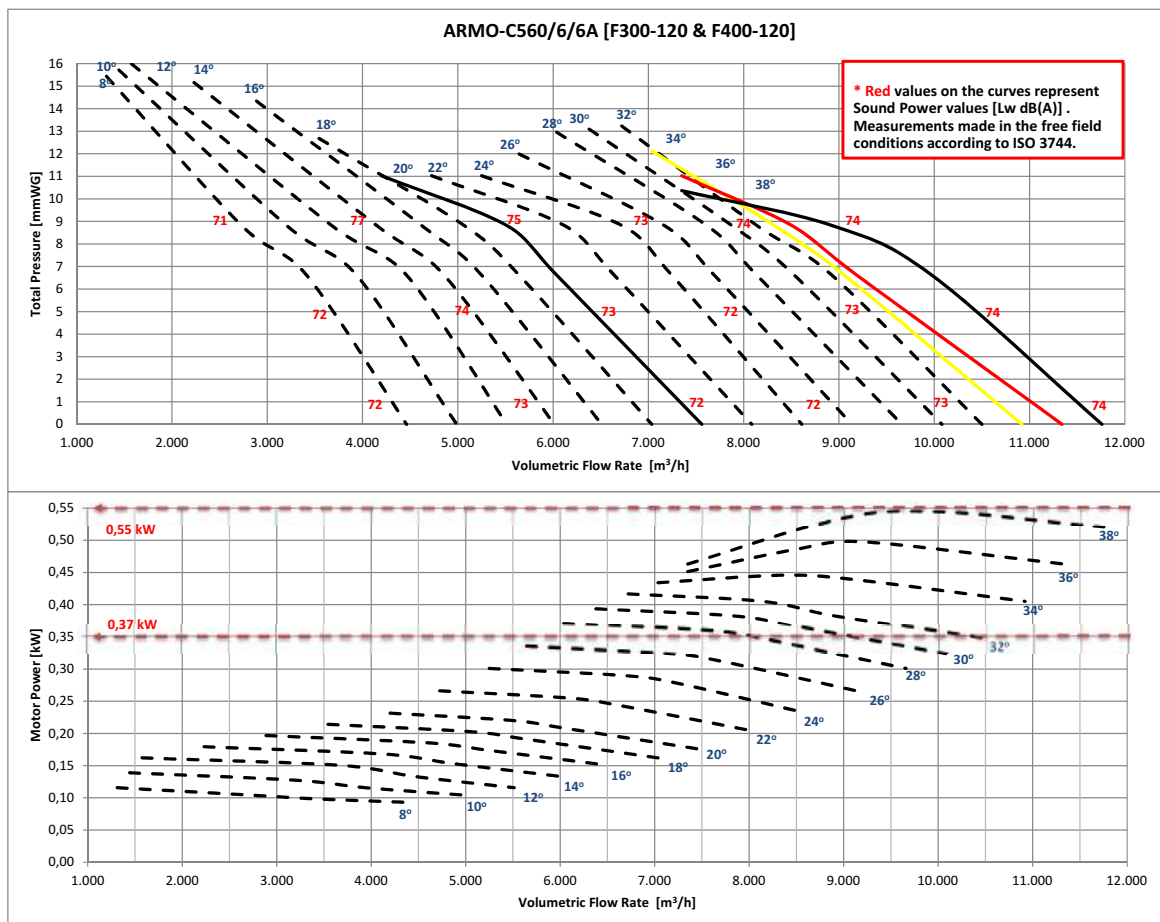
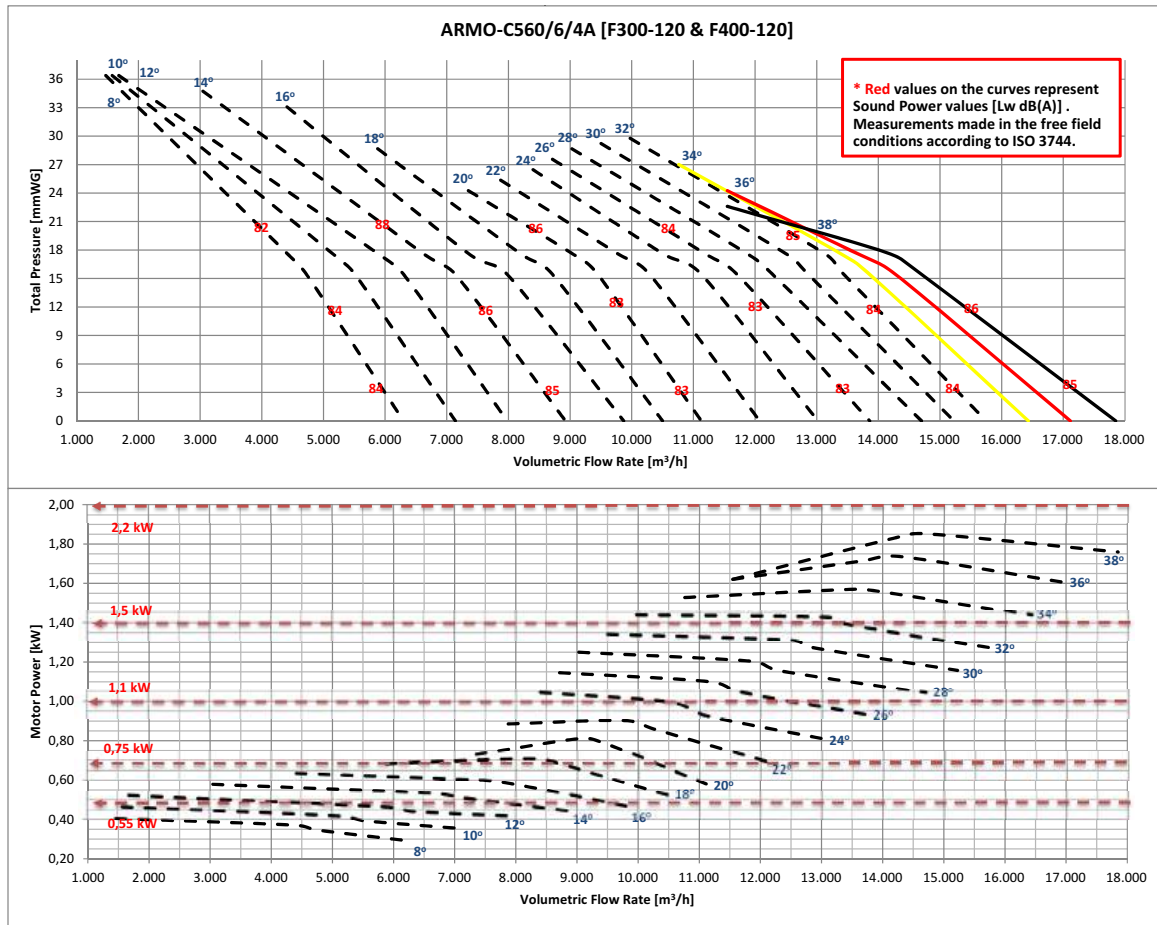

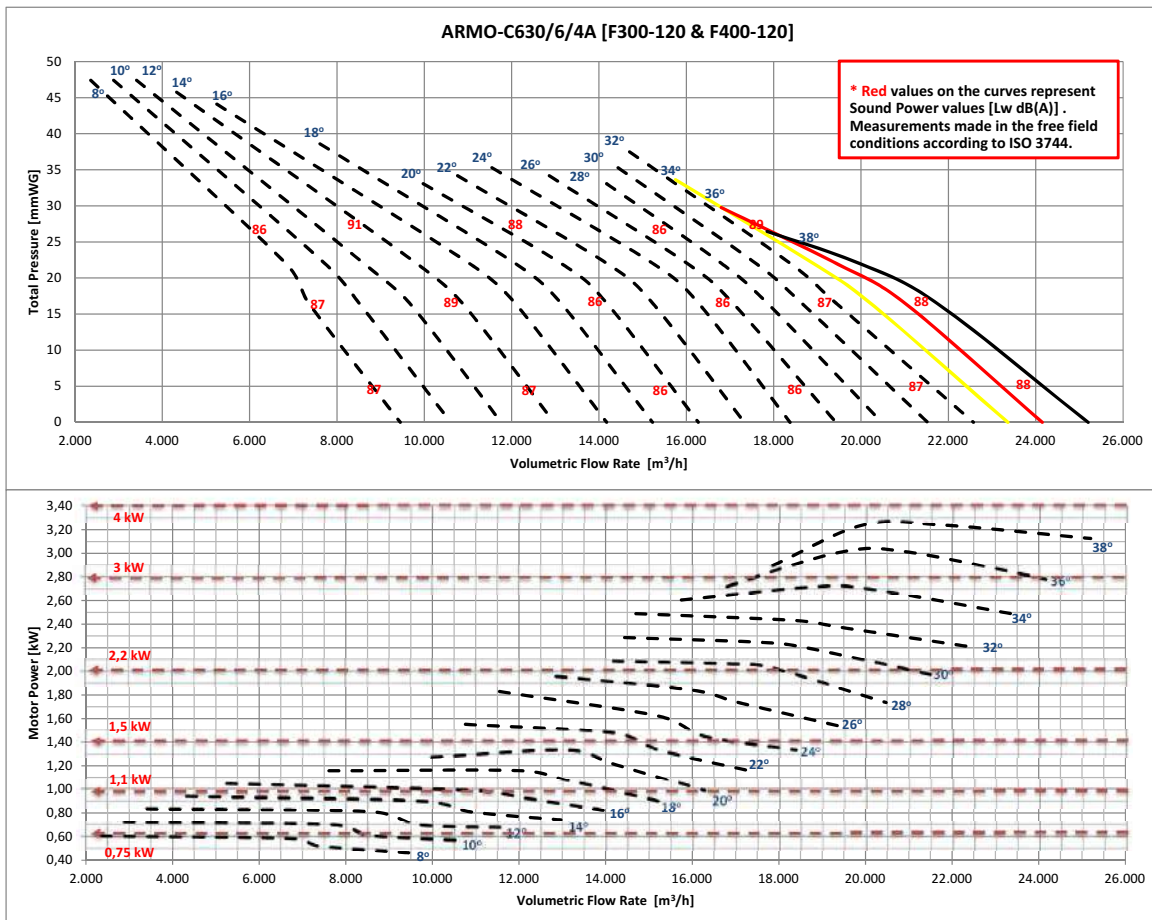
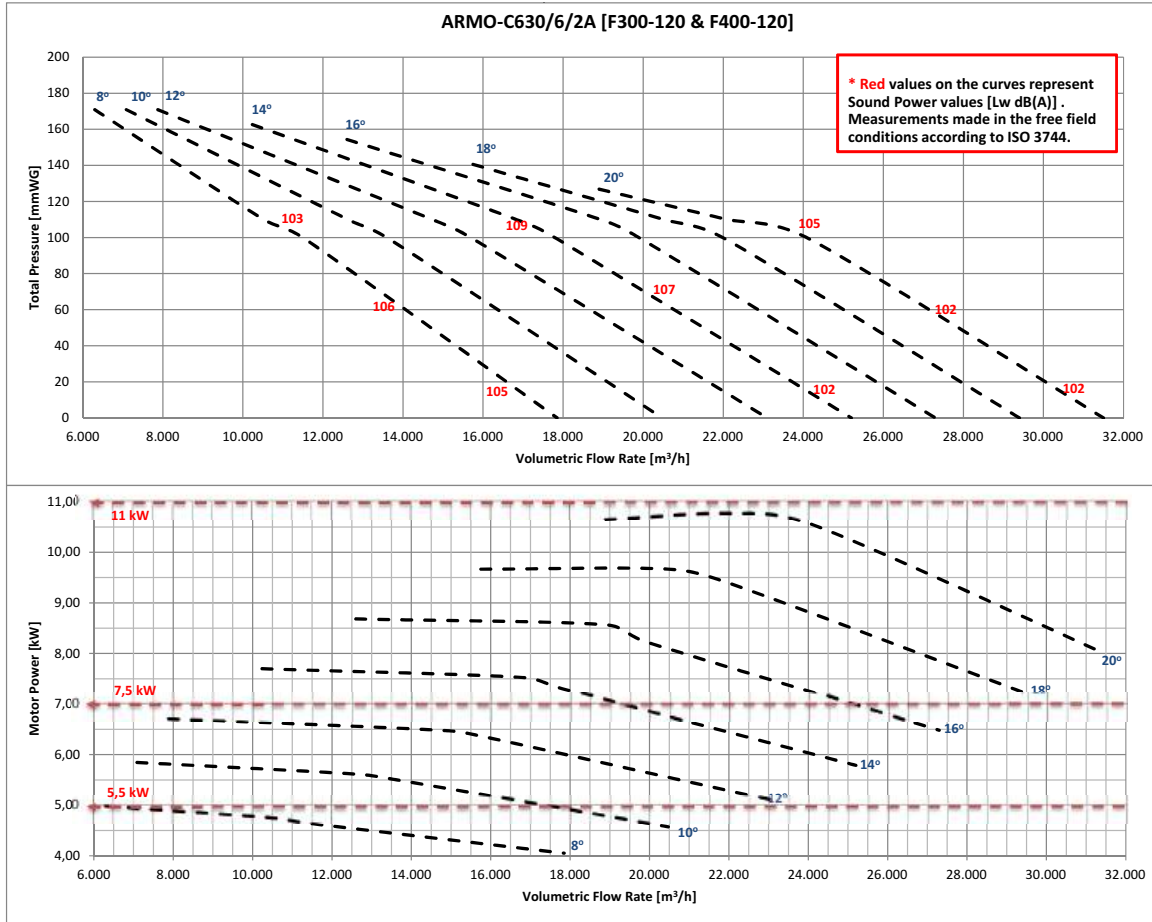

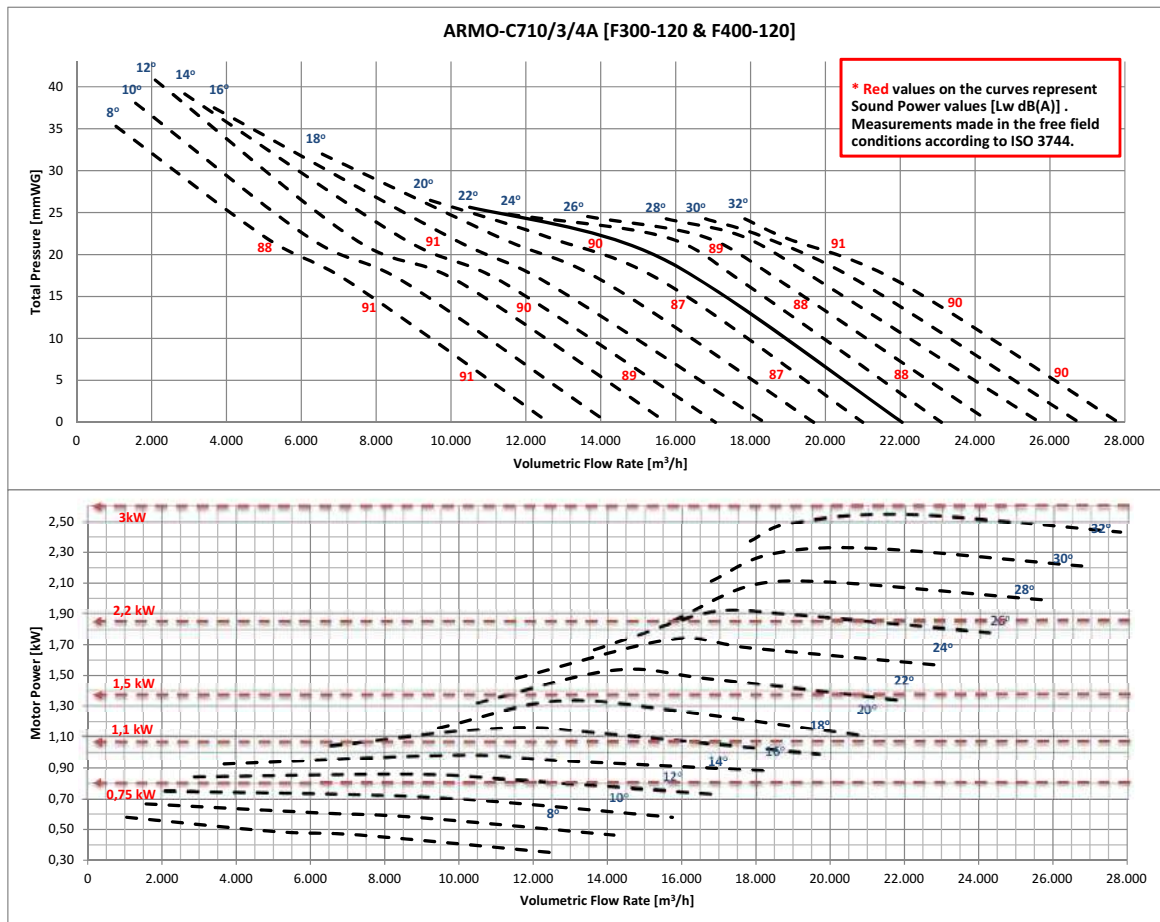
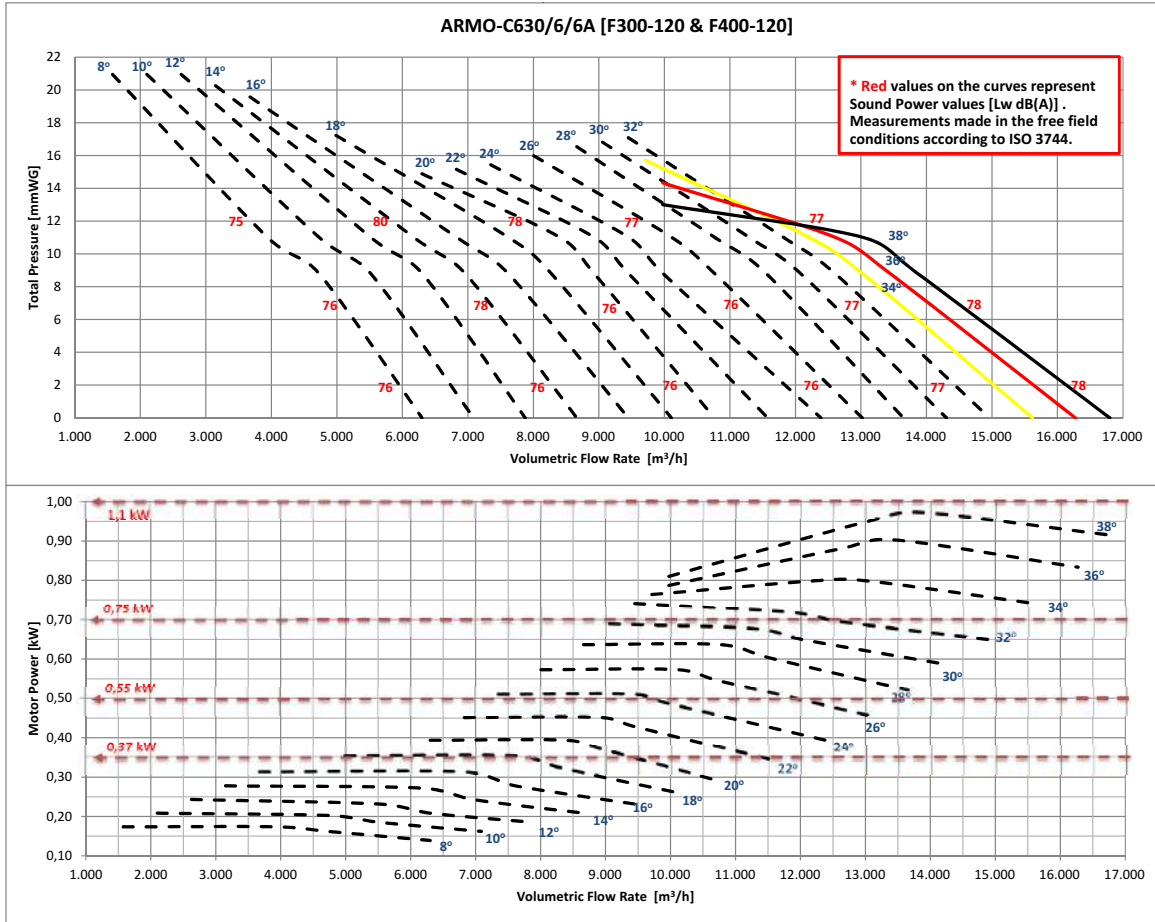

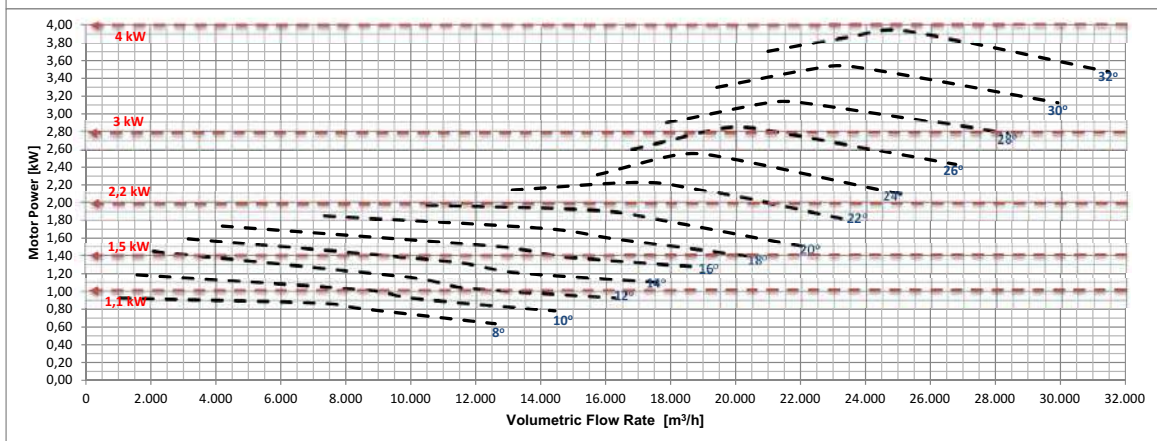
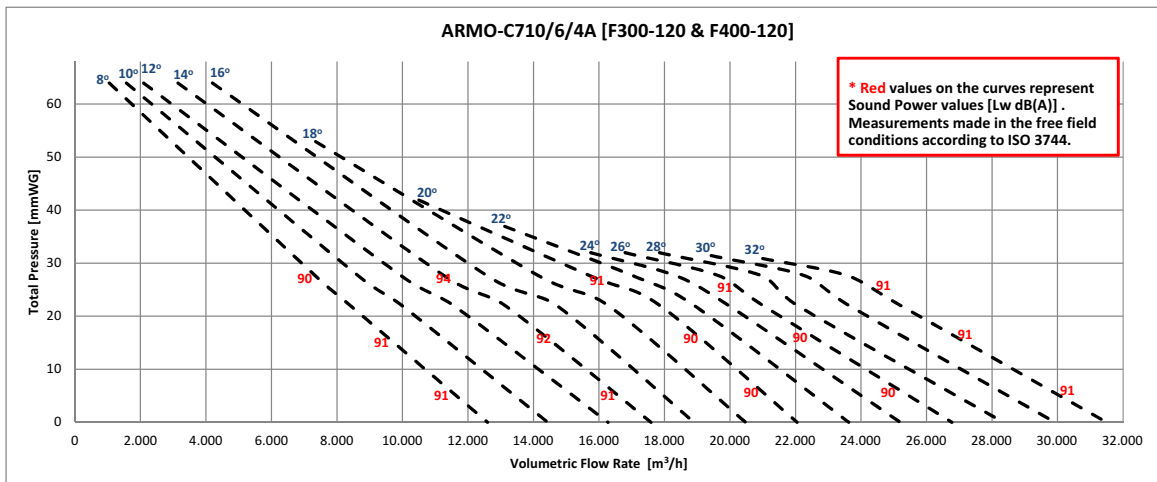
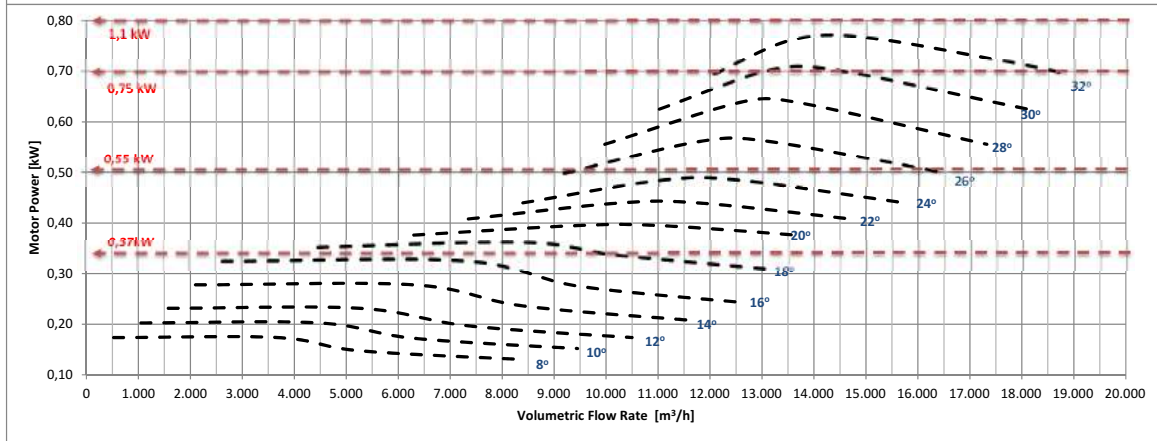
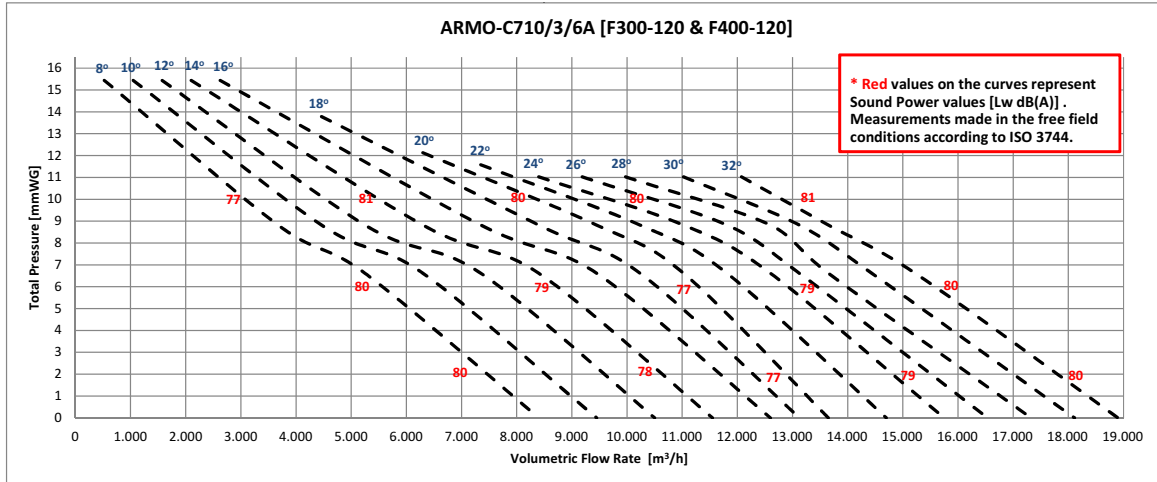

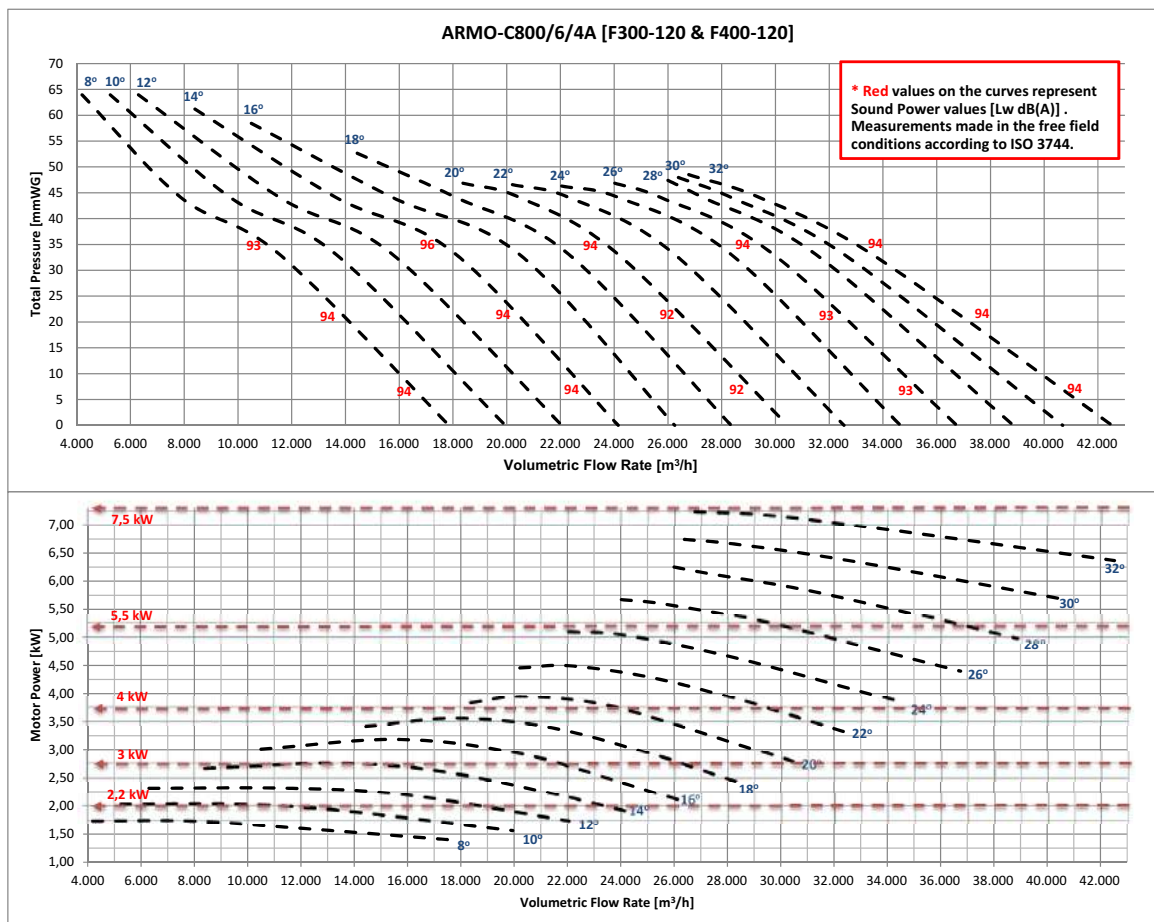
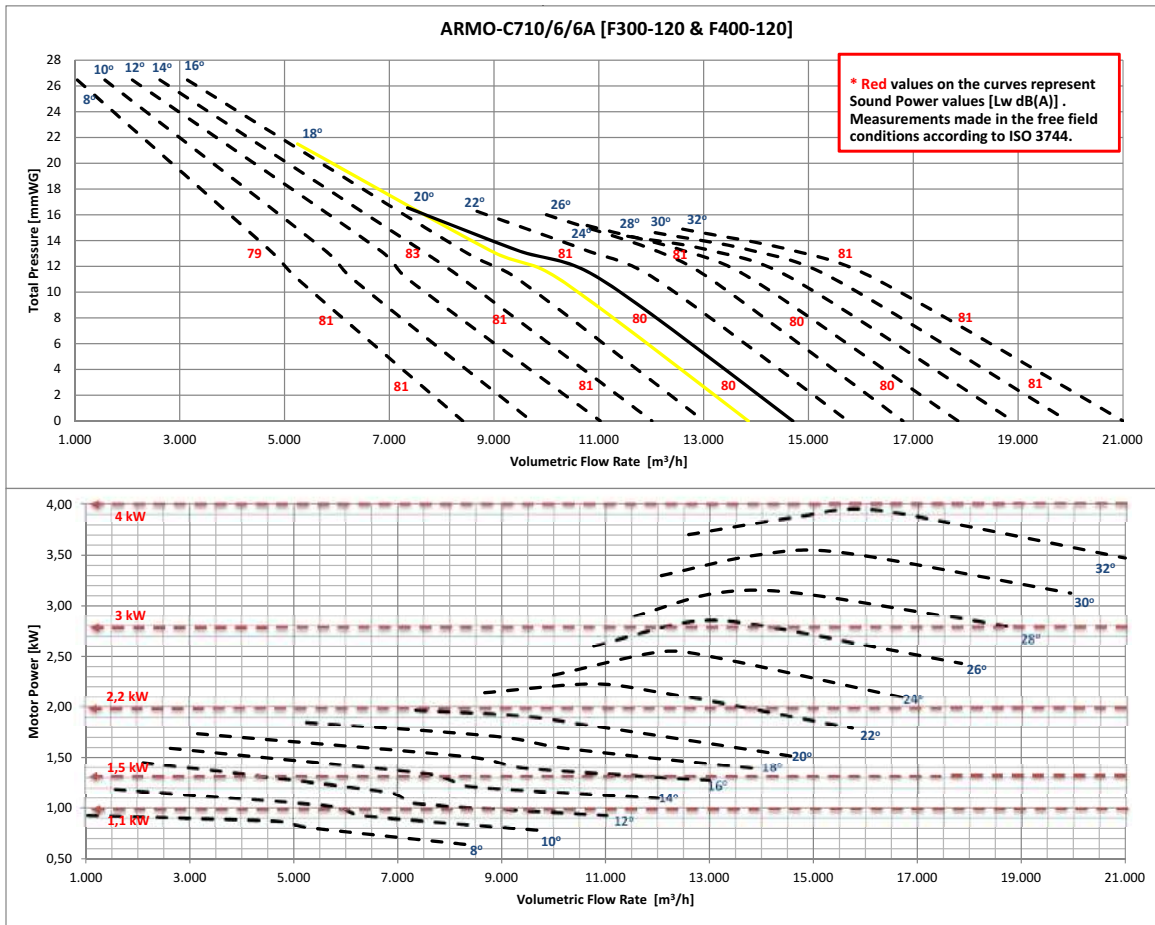

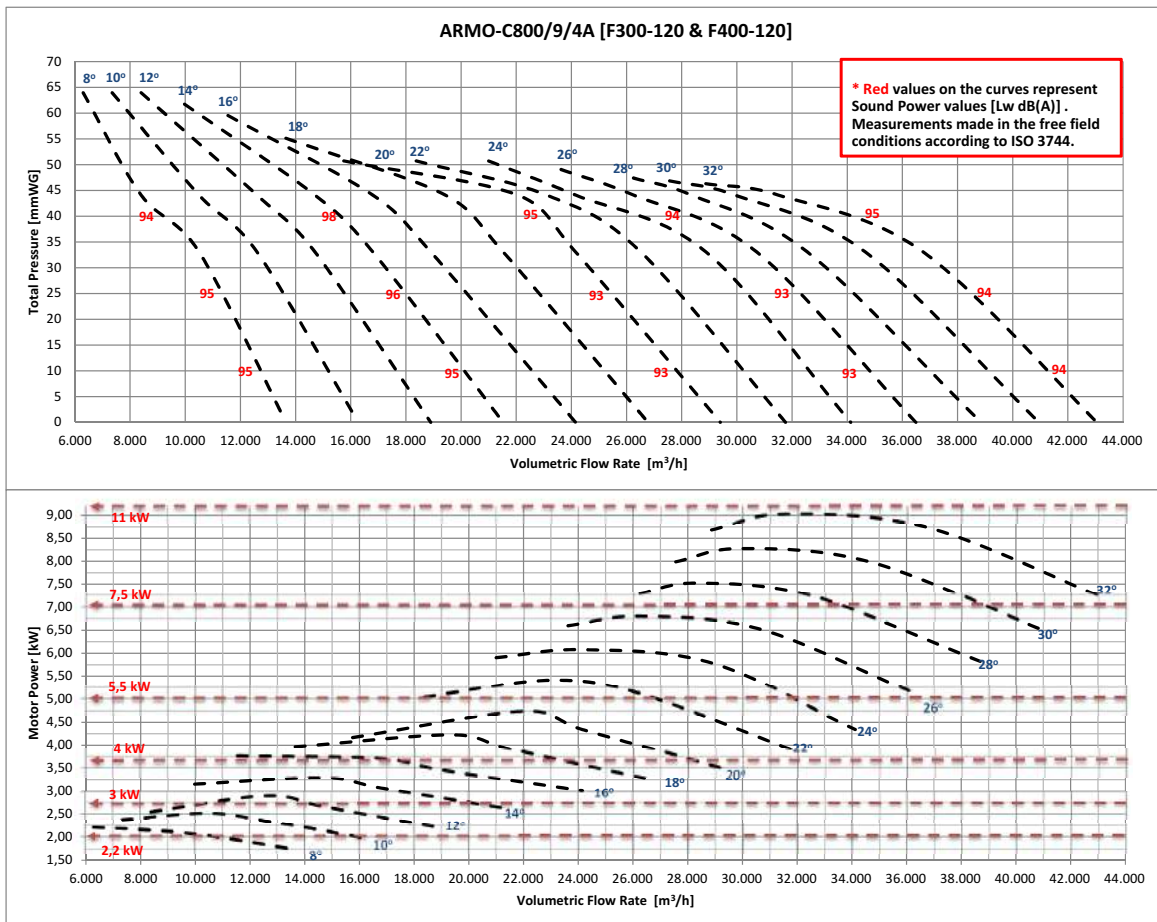
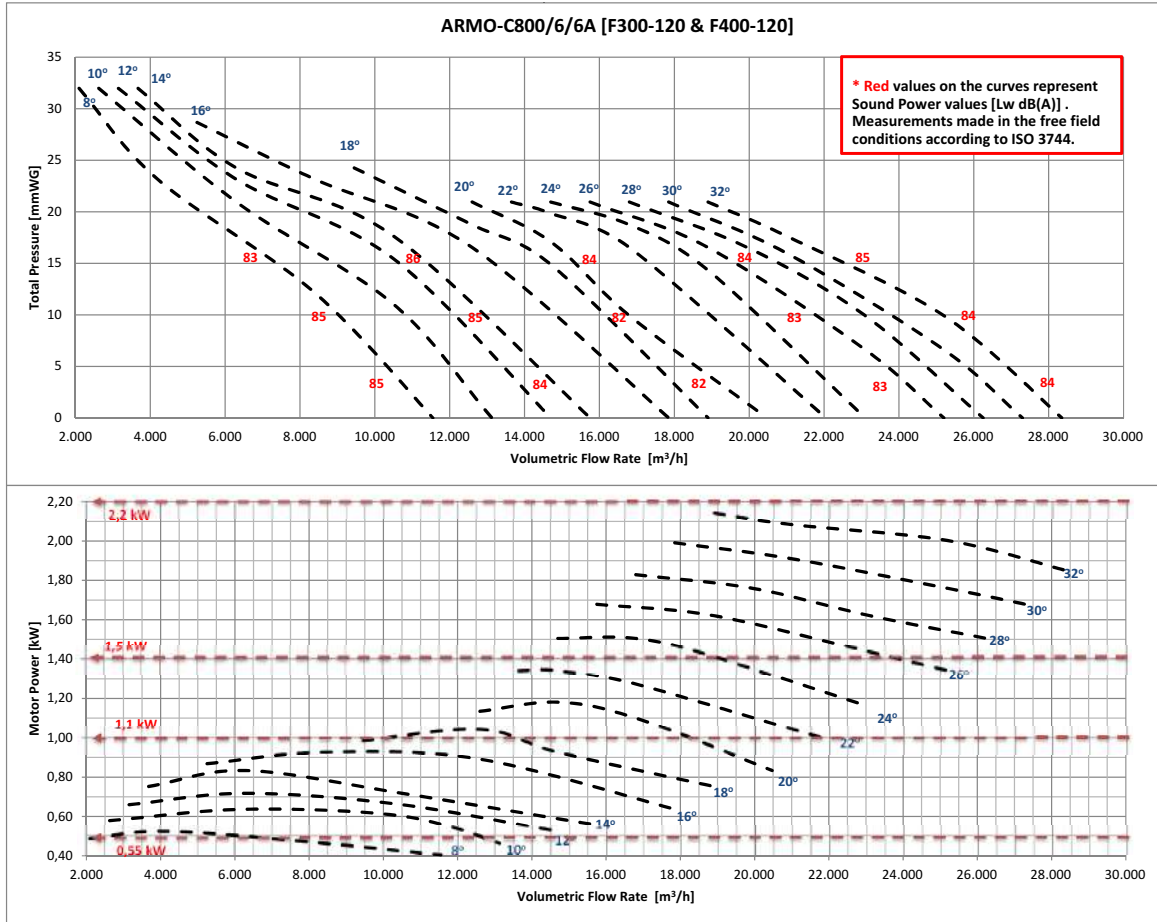

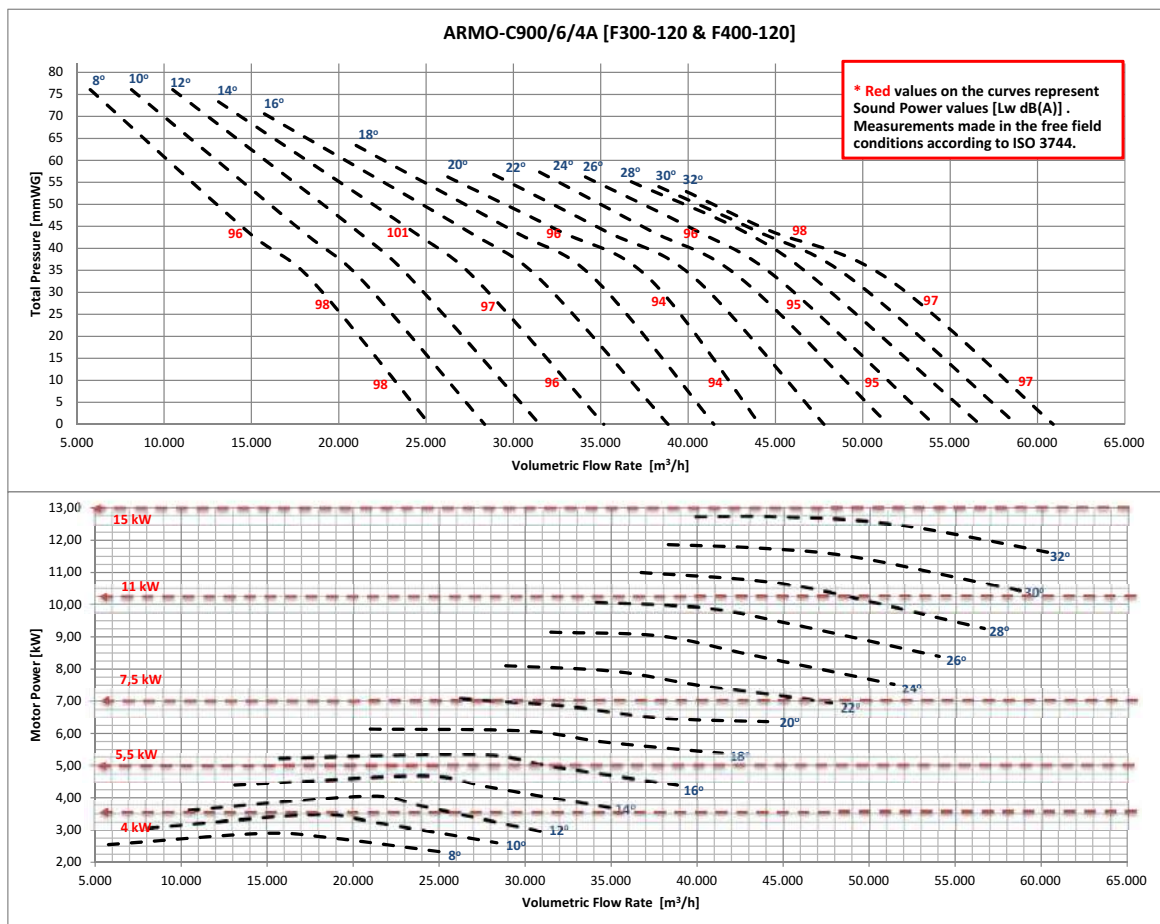
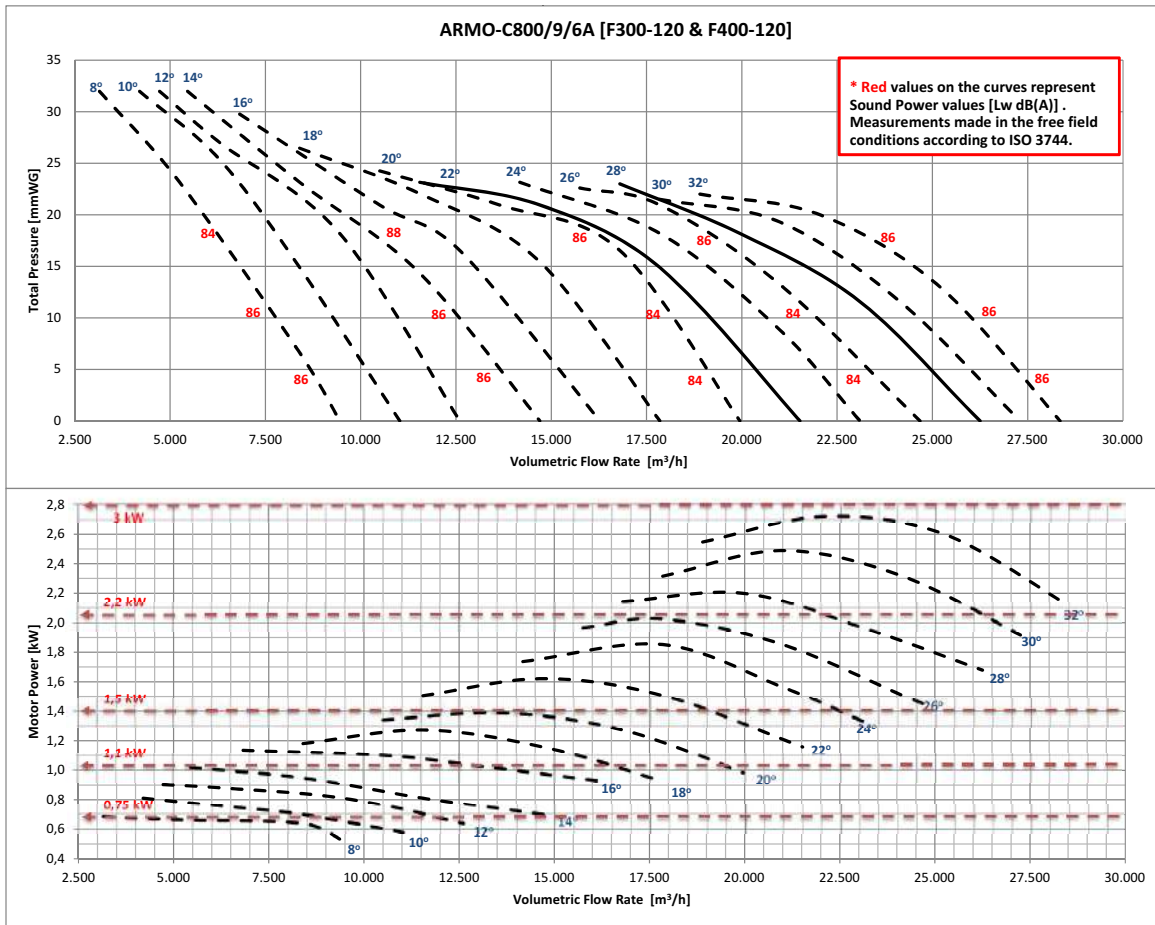

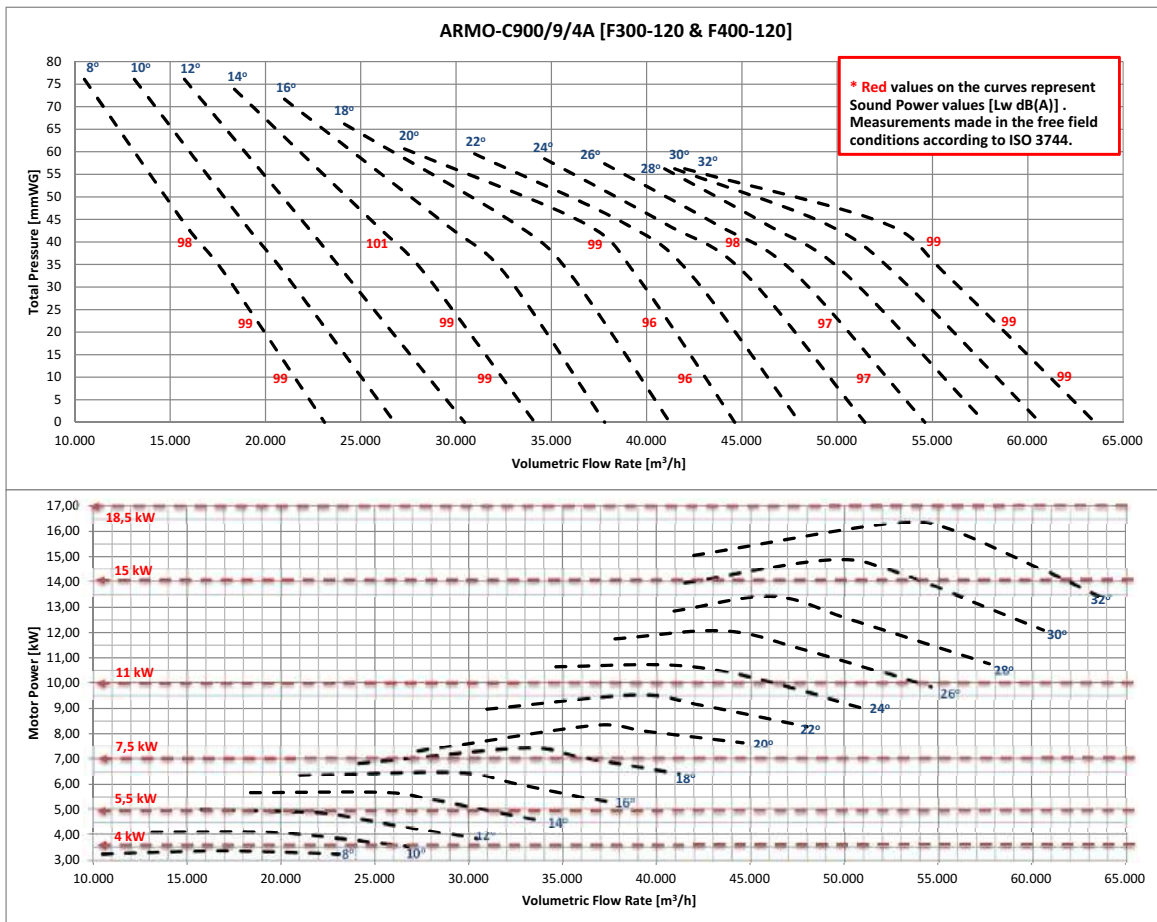
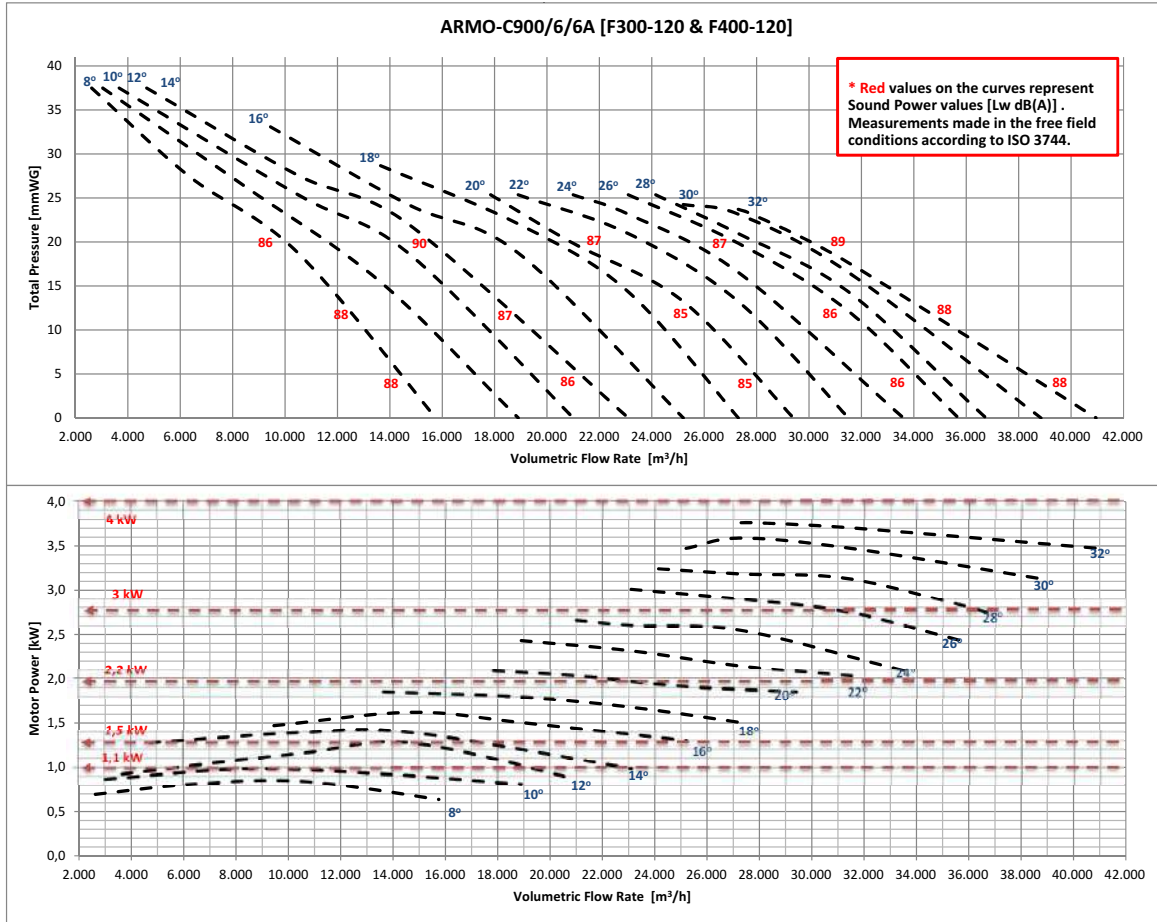

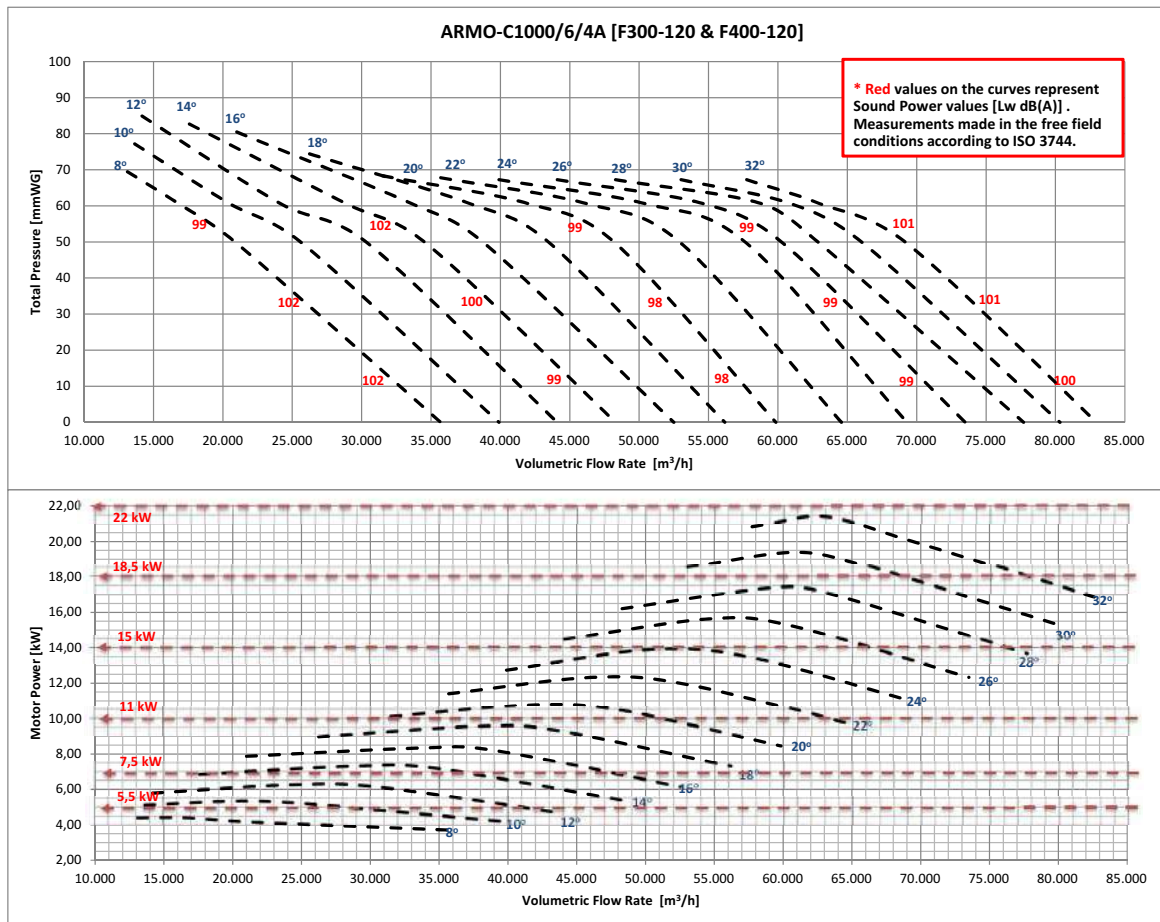
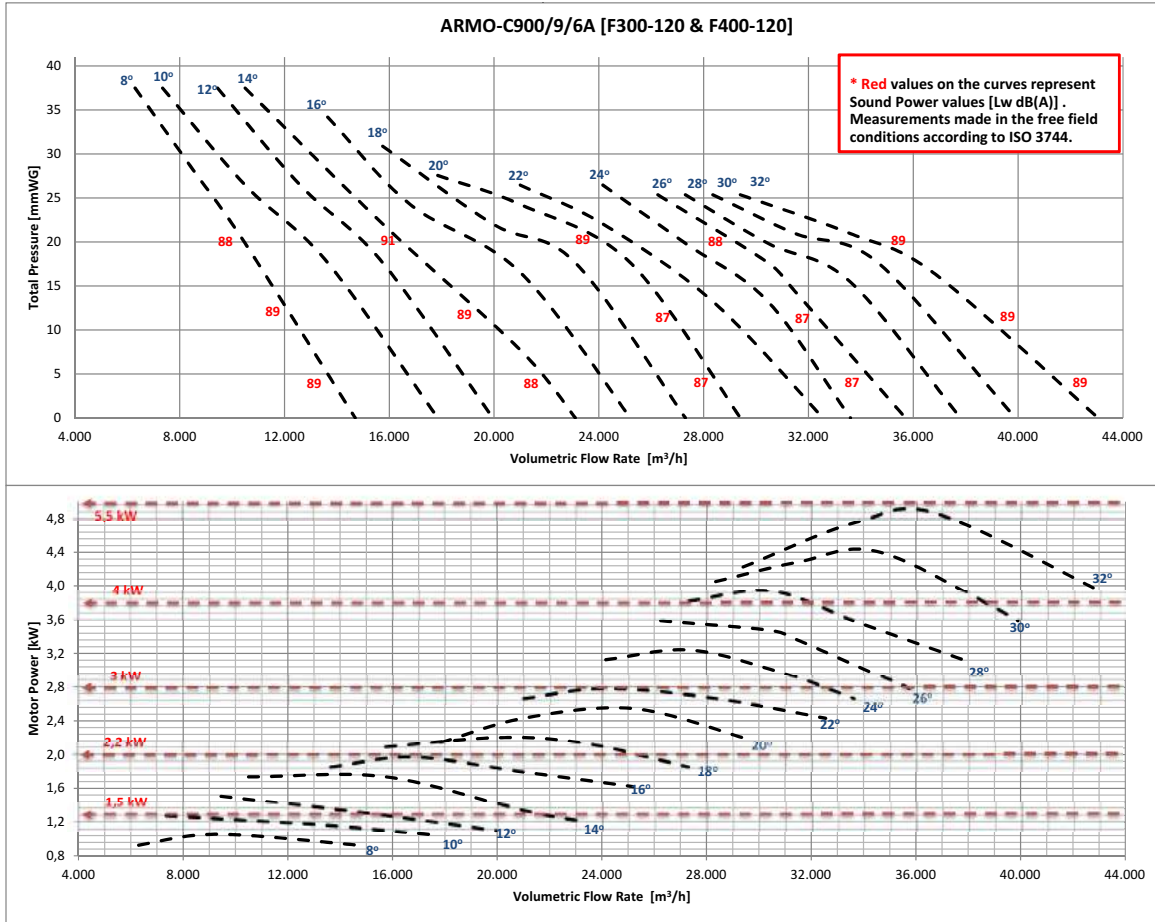

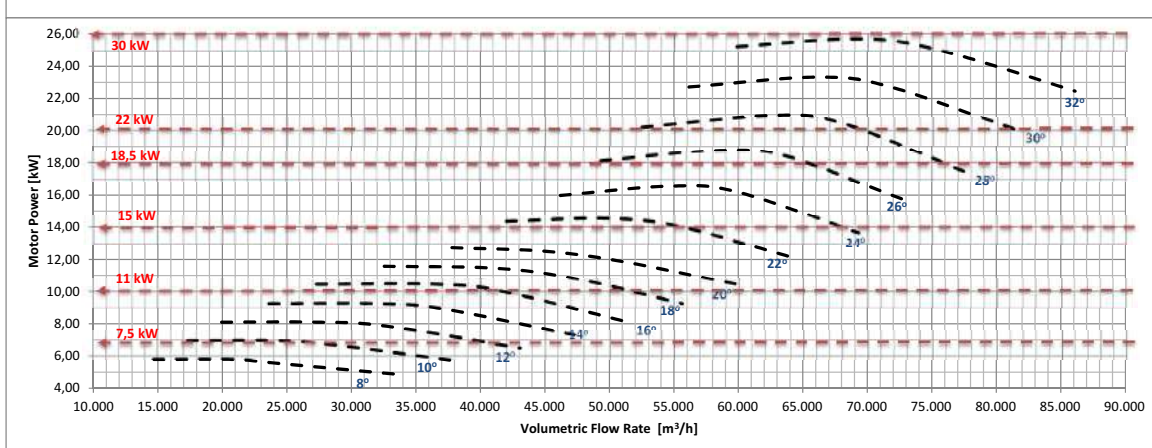
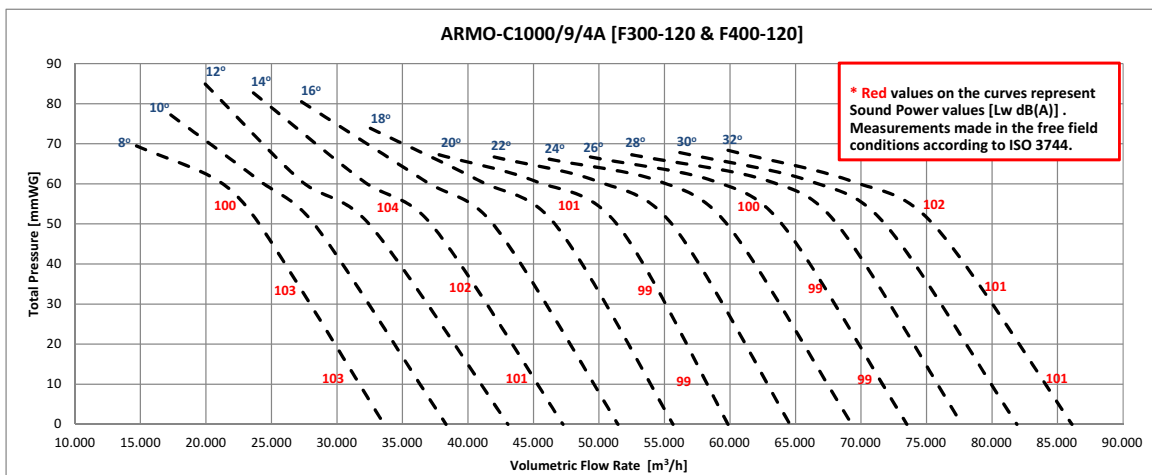
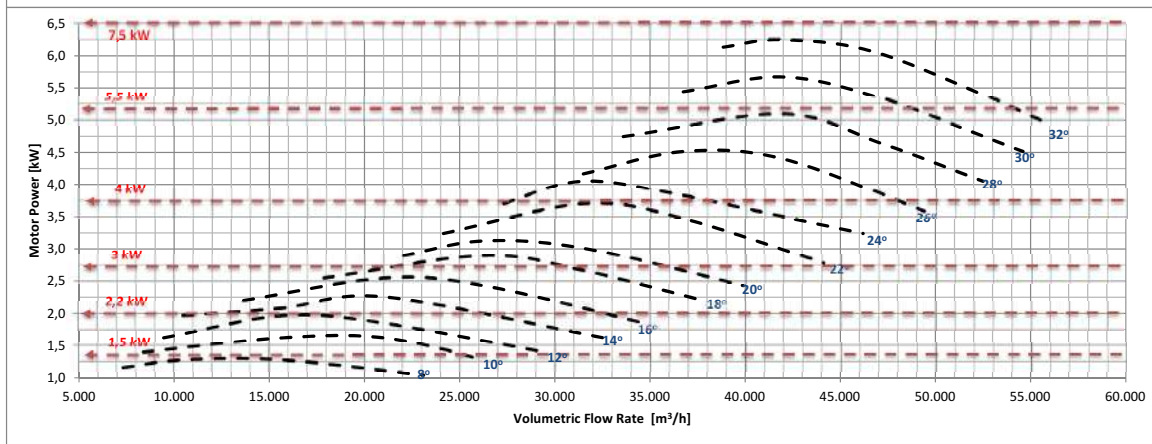
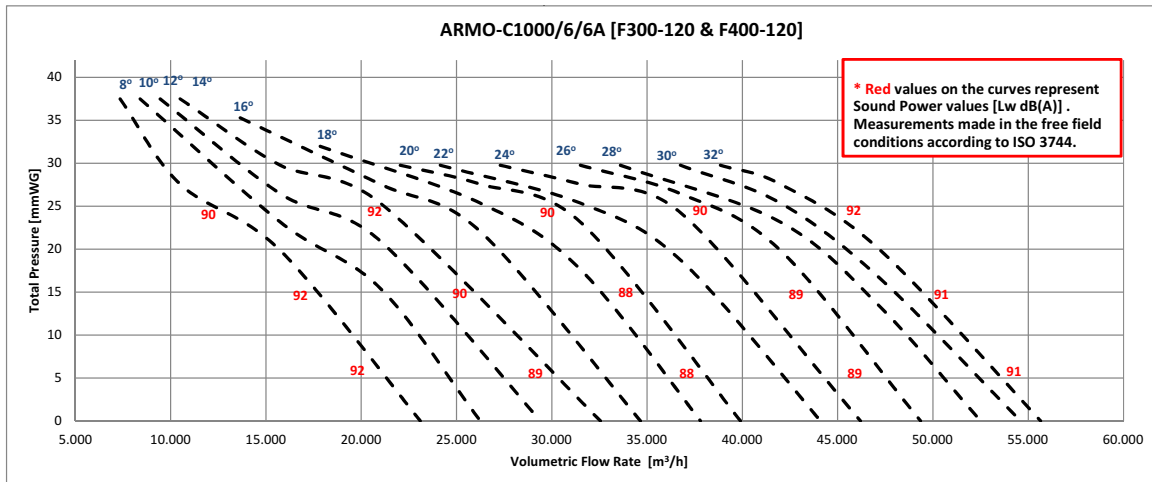

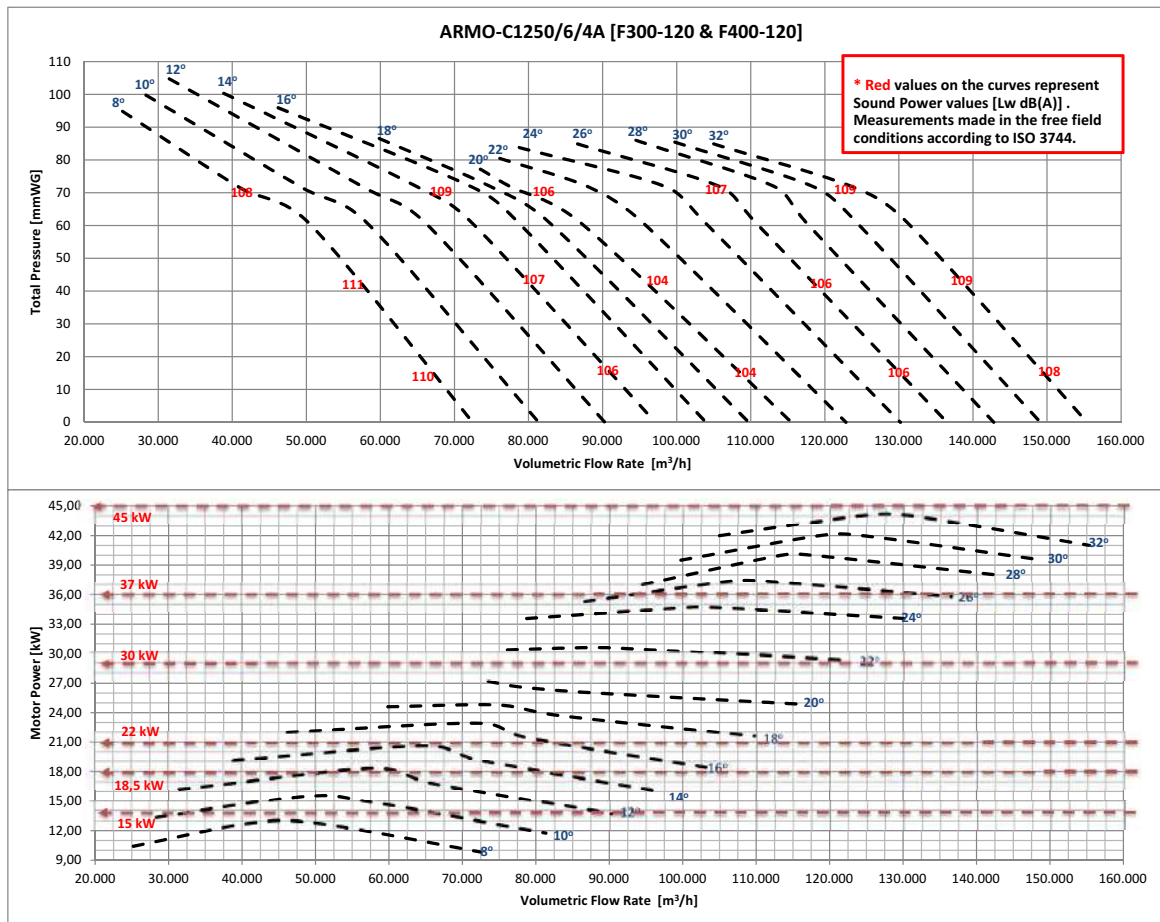
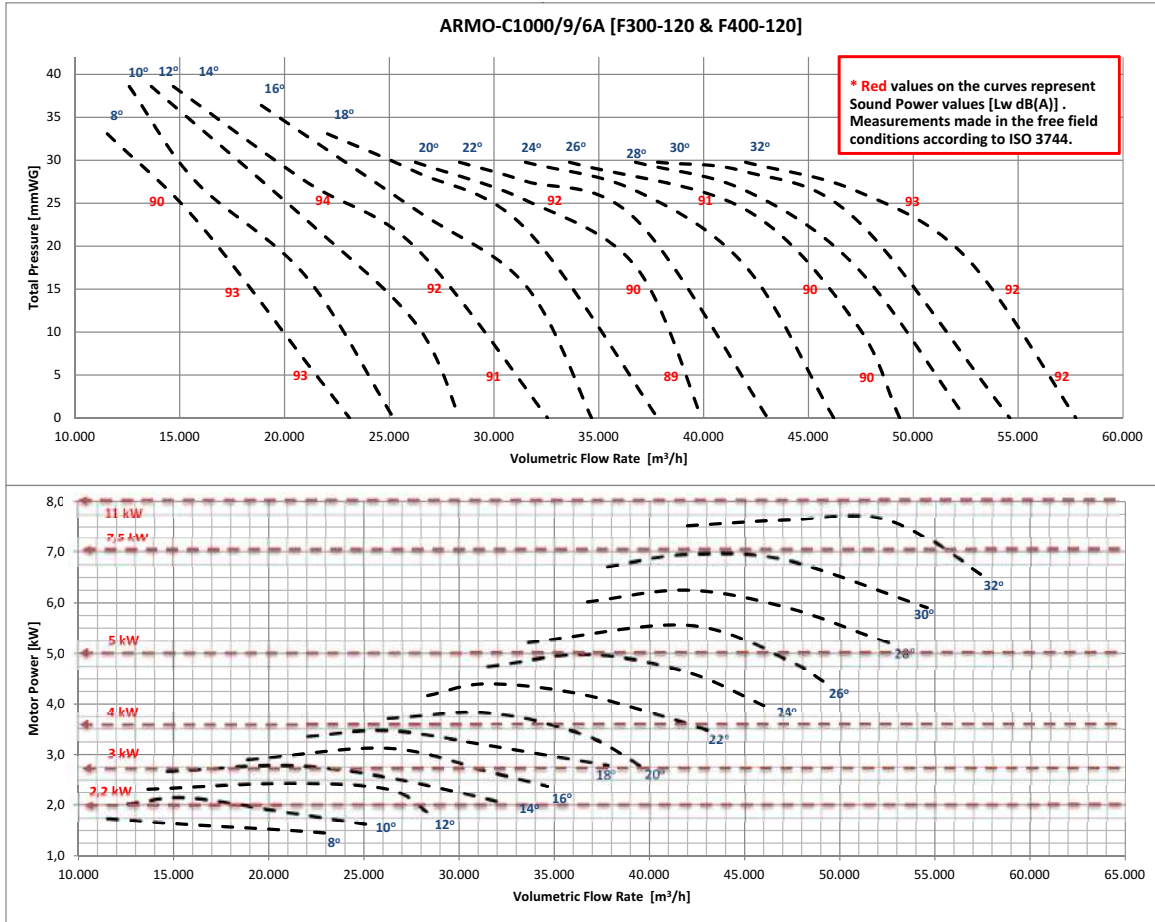

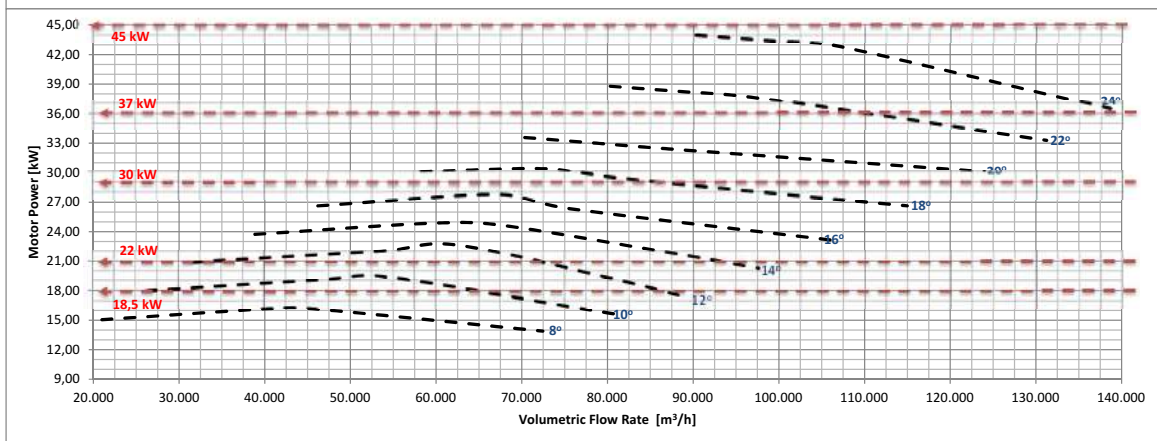
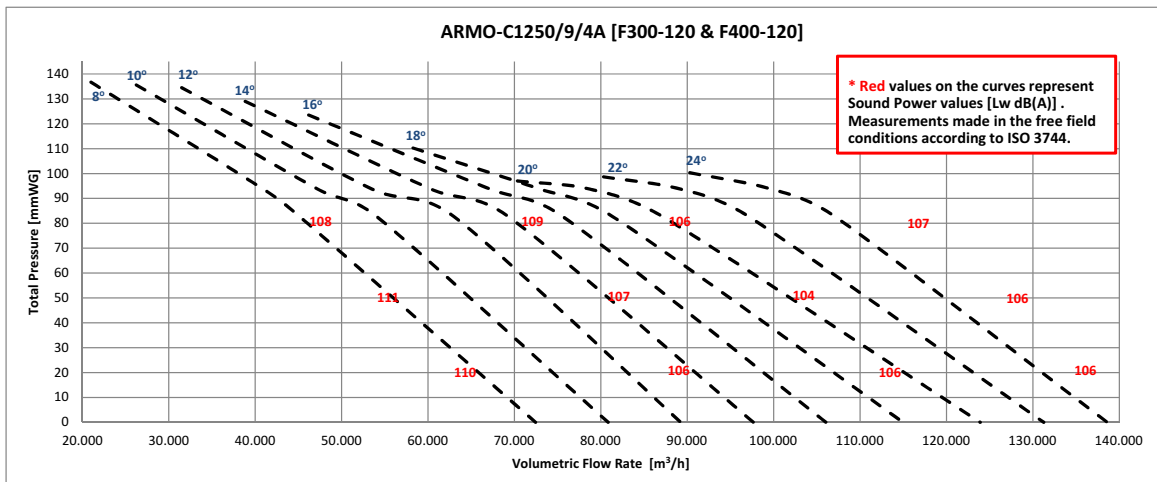
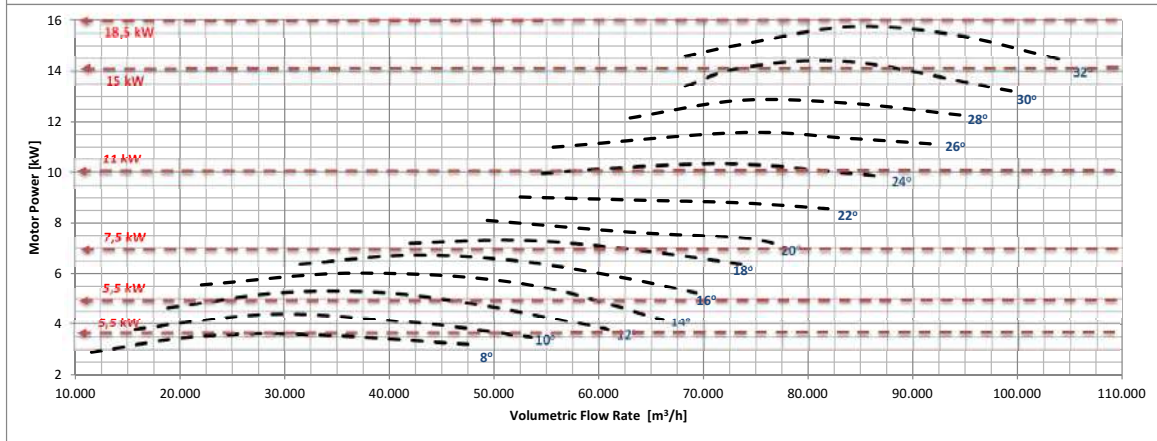
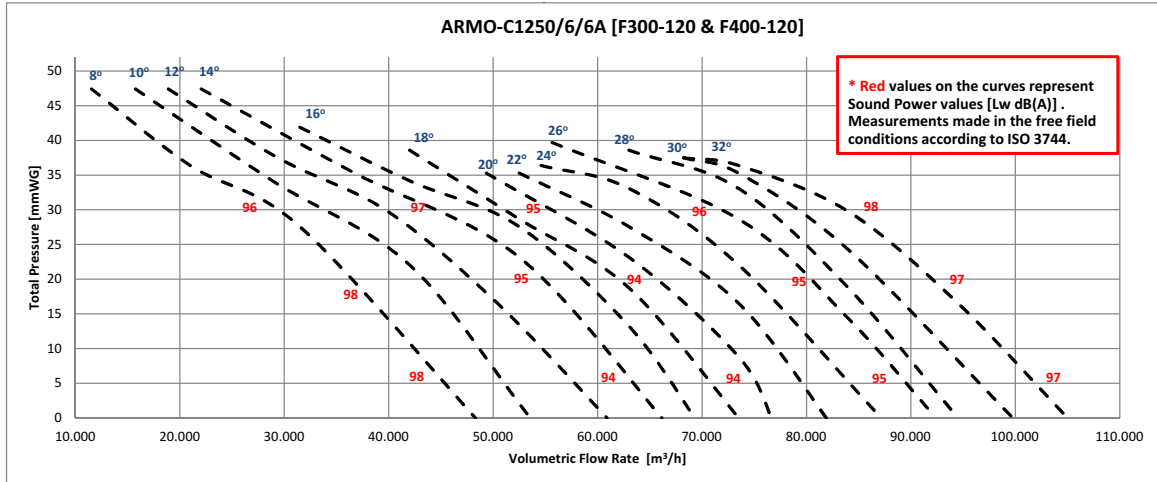

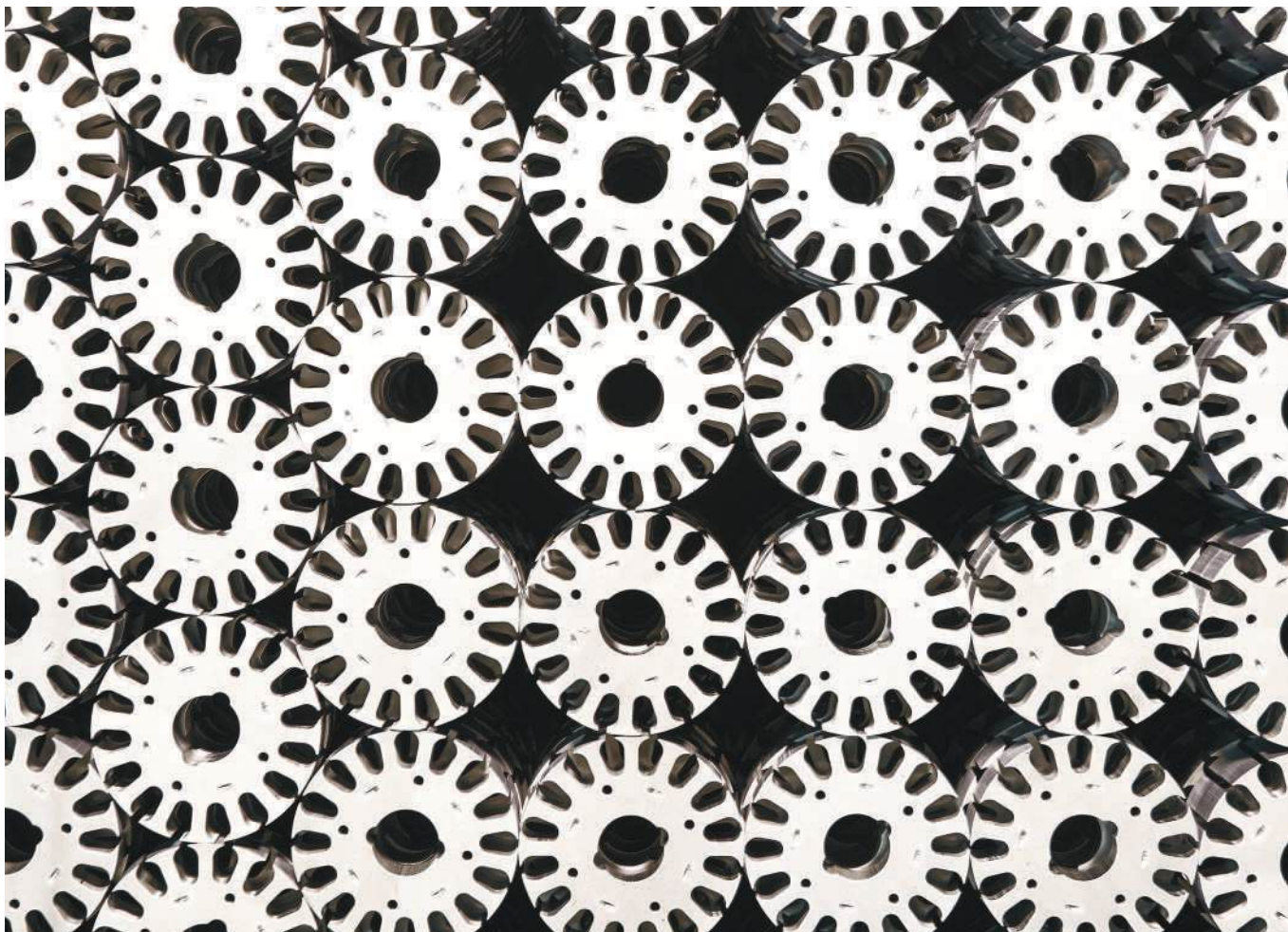
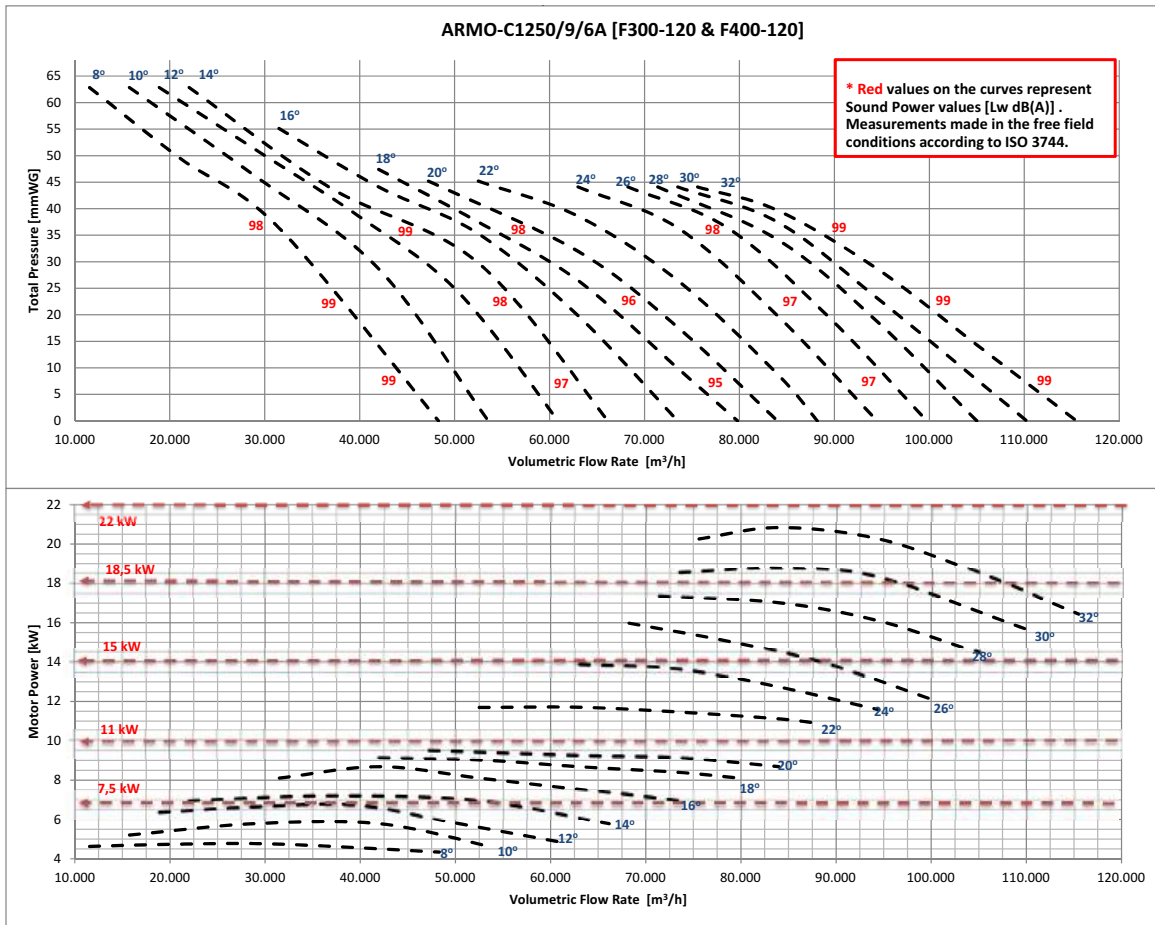



ARMO-R

SMOKE AND HEAT EXHAUST FANS / Roof



Axial roof fans are used in pressurization fan, fresh air fan and smoke exhaust fan applications. The enclosure is fire resistant and designed according to the noise standard. Smoke evacuation fans are fire resistant.

General Features

- It has EN 12101-3 and Ce certificates.
- 2 hours continuous operation at 400 C and 300 C
- There is a wide product range from 400 mm to 1250 mm.

Rotor Features

- Fire resistant aluminum alloy casting blades and fan hub.
- Has the ability to work one-way and two-way. The blades are specially designed according to each direction type.
- There is no aerodynamic loss in the case of reversible wing type operation.
- Wings are airfoil and provide high aerodynamic performance in both unidirectional and bidirectional vanes.
- Wing angles are adjustable. In this way, smoke discharge fans can be demanded at different flow rates and pressures.
- The fan part of

the fan is dynamically balanced according to ISO 1940 and there is no eccentricity during the operation of the fan.

Body Features

- Fan body is steel sheet. Body is hot dip galvanized and corrosion resistant.
- It has short type body and long type body types.

Motor Features

- Offers 2.4 and 6-pole motors
- The motors are IP 55 class and Class-H insulated.
- All electric motor models are approved for continuous operation (S1) and Emergency operation (S2).

Ease of Maintenance

A maintenance cover is provided to ensure easy maintenance.

Usage Areas

Roof type Axial fans are used in pressurization fan, fresh air fan and smoke exhaust fan applications.

Technical Drawing and Tables

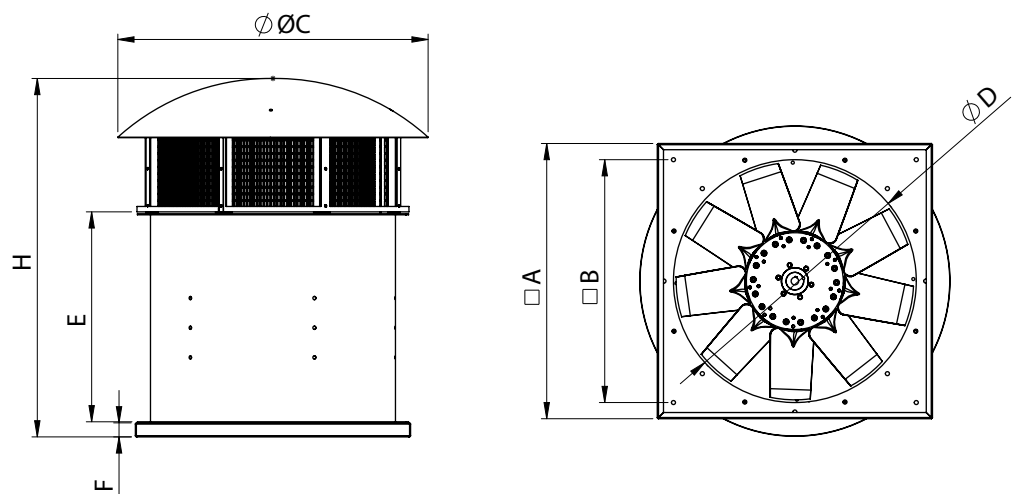

TYPE	A	B	C	D	E	H	F
ARMO-R 400	600	495	702	400	474	880	50
ARMO-R 450	650	545	702	450	474	880	50
ARMO-R 500	650	545	842	500	580	1030	50
ARMO-R 560	685	605	842	560	580	1030	50
ARMO-R 630	780	637	1130	630	600	1160	50
ARMO-R 710	830	710	1130	800	700	1300	50
ARMO-R 800	920	800	1130	800	700	1300	50
ARMO-R 900	1020	900	1130	900	775	1375	50
ARMO-R 1000	1130	1030	1430	1000	850	1450	50
ARMO-R 1250	1430	1350	1430	1250	950	1550	50

Dimensions are in (mm)



2 POLE TYPE	SPEED	DIAMETER	POWER	CURRENT	AIR FLOW	WING ANGLE
	r.p.m	mm	kW	230V - 400V	m ³ /h	
ARMO-R / 400-6 / 0,75 - 2A	2900	400	0,75	1,6	5250	16°
ARMO-R / 400-6 / 1,1 - 2A	2900	400	1,1	2,3	6904	22°
ARMO-R / 400-6 / 1,5 - 2A	2900	400	1,5	3,4	8978	30°
ARMO-R / 400-6 / 2,2 - 2A	2900	400	2,2	4,48	9975	34°
ARMO-R / 450-6 / 1,1 - 2A	2900	450	1,1	2,3	6248	10°
ARMO-R / 450-6 / 1,5 - 2A	2900	450	1,5	3,4	8610	16°
ARMO-R / 450-6 / 2,2 - 2A	2900	450	2,2	4,48	11970	24°
ARMO-R / 450-6 / 3 - 2A	2900	450	3	6	13545	28°
ARMO-R / 500-6 / 2,2 - 2A	2900	500	2,2	4,48	11000	14°
ARMO-R / 500-6 / 3 - 2A	2900	500	3	6	14595	20°
ARMO-R / 500-6 / 4 - 2A	2900	500	4	7,4	17325	26°
ARMO-R / 500-6 / 5,5 - 2A	2900	500	5,5	11	18375	28°
ARMO-R / 560-6 / 4 - 2A	2900	560	4	7,4	17850	14°
ARMO-R / 560-6 / 5,5 - 2A	2900	560	5,5	11	22313	20°
ARMO-R / 560-6 / 7,5 - 2A	2800	560	7,5	13,6	25725	24°
ARMO-R / 630-6 / 5,5 - 2A	2900	630	5,5	11	20475	10°
ARMO-R / 630-6 / 7,5 - 2A	2800	630	7,5	13,6	27300	16°

4 POLE TYPE	SPEED	DIAMETER	POWER	CURRENT	AIR FLOW	WING ANGLE
	r.p.m	mm	kW	230V - 400V	m ³ /h	
ARMO-R / 500-6 / 0,55 - 4A	1415	500	0,55	1,6	8715	26
ARMO-R / 500-6 / 0,75 - 4A	1350	500	0,75	2,1	10290	32
ARMO-R / 500-6 / 1,1 - 4A	1400	500	1,1	2,6	12600	38
ARMO-R / 560-6 / 0,55 - 4A	1415	560	0,55	1,6	9870	16
ARMO-R / 560-6 / 0,75 - 4A	1350	560	0,75	2,1	12075	22
ARMO-R / 560-6 / 1,1 - 4A	1400	560	1,1	2,6	13860	26
ARMO-R / 560-6 / 1,5 - 4A	1405	560	1,5	3,5	15750	32
ARMO-R / 560-6 / 2,2 - 4A	1410	560	2,2	5	17850	38
ARMO-R / 630-6 / 0,75 - 4A	1350	630	0,75	2,1	10605	10
ARMO-R / 630-6 / 1,1 - 4A	1400	630	1,1	2,6	16275	20
ARMO-R / 630-6 / 1,5 - 4A	1405	630	1,5	3,5	18375	24
ARMO-R / 630-6 / 2,2 - 4A	1410	630	2,2	5	21525	30
ARMO-R / 630-6 / 3 - 4A	1410	630	3	6,6	24150	36
ARMO-R / 630-6 / 4 - 4A	1500	630	4	8,2	25200	38
ARMO-R / 710-3 / 0,75 - 4A	1350	710	0,75	2,1	14175	10
ARMO-R / 710-3 / 1,1 - 4A	1400	710	1,1	2,6	18375	16
ARMO-R / 710-3 / 1,5 - 4A	1405	710	1,5	3,5	21000	20
ARMO-R / 710-3 / 2,2 - 4A	1410	710	2,2	5	24413	26
ARMO-R / 710-3 / 3 - 4A	1410	710	3	6,6	27825	32
ARMO-R / 710-6 / 1,1 - 4A	1400	710	1,1	2,6	16275	12
ARMO-R / 710-6 / 1,5 - 4A	1405	710	1,5	3,5	20475	18
ARMO-R / 710-6 / 2,2 - 4A	1410	710	2,2	5	23625	22
ARMO-R / 710-6 / 3 - 4A	1410	710	3	6,6	28350	28
ARMO-R / 710-6 / 4 - 4A	1415	710	4	8,2	31500	32
ARMO-R / 800-6 / 2,2 - 4A	1410	800	2,2	5	24150	14
ARMO-R / 800-6 / 3 - 4A	1410	800	3	6,6	30450	20
ARMO-R / 800-6 / 4 - 4A	1415	800	4	8,2	32550	22
ARMO-R / 800-6 / 5,5 - 4A	1430	800	5,5	11,2	38850	28
ARMO-R / 800-6 / 7,5 - 4A	1440	800	7,5	15,4	42525	32
ARMO-R / 800-9 / 2,2 - 4A	1410	800	2,2	5	16275	10
ARMO-R / 800-9 / 3 - 4A	1410	800	3	6,6	21525	14
ARMO-R / 800-9 / 4 - 4A	1415	800	4	8,2	29400	20
ARMO-R / 800-9 / 5,5 - 4A	1430	800	5,5	11,2	36488	26
ARMO-R / 800-9 / 7,5 - 4A	1440	800	7,5	15,4	40950	30
ARMO-R / 800-9 / 11 - 4A	1450	800	11	21	43050	32
ARMO-R / 900-6 / 4 - 4A	1415	900	4	8,2	31500	12
ARMO-R / 900-6 / 5,5 - 4A	1430	900	5,5	11,2	38850	16
ARMO-R / 900-6 / 7,5 - 4A	1440	900	7,5	15,4	47775	22
ARMO-R / 900-6 / 11 - 4A	1450	900	11	21	56700	28
ARMO-R / 900-6 / 15 - 4A	1450	900	15	29,3	60900	32
ARMO-R / 900-9 / 4 - 4A	1415	900	4	8,2	26775	10
ARMO-R / 900-9 / 5,5 - 4A	1430	900	5,5	11,2	34125	14
ARMO-R / 900-9 / 7,5 - 4A	1440	900	7,5	15,4	41213	18
ARMO-R / 900-9 / 11 - 4A	1450	900	11	21	54600	26
ARMO-R / 900-9 / 15 - 4A	1450	900	15	29,3	63525	32
ARMO-R / 1000-6 / 5,5 - 4A	1430	1000	5,5	11,2	38850	12
ARMO-R / 1000-6 / 7,5 - 4A	1440	1000	7,5	15,4	47775	18
ARMO-R / 1000-6 / 11 - 4A	1450	1000	11	21	56700	22
ARMO-R / 1000-6 / 15 - 4A	1450	1000	15	29,3	60900	28
ARMO-R / 1000-6 / 18,5 - 4A	1455	1000	18,5	34,5	56700	32
ARMO-R / 1000-9 / 7,5 - 4A	1440	1000	7,5	15,4	43050	12
ARMO-R / 1000-9 / 11 - 4A	1450	1000	11	21	55650	18
ARMO-R / 1000-9 / 15 - 4A	1450	1000	15	29,3	69300	24
ARMO-R / 1000-9 / 18,5 - 4A	1455	1000	18,5	34,5	77700	28
ARMO-R / 1000-9 / 22 - 4A	1460	1000	22	42,5	81900	30
ARMO-R / 1000-9 / 30 - 4A	1460	1000	30	55	86100	32
ARMO-R / 1250-6 / 15 - 4A	1450	1250	15	29,3	90300	12
ARMO-R / 1250-6 / 18,5 - 4A	1455	1250	18,5	34,5	103950	16
ARMO-R / 1250-6 / 22 - 4A	1460	1250	22	42,5	109725	18
ARMO-R / 1250-6 / 30 - 4A	1460	1250	30	55	122850	22
ARMO-R / 1250-6 / 37 - 4A	1470	1250	37	67	136500	26
ARMO-R / 1250-6 / 45 - 4A	1475	1250	45	80	155400	32
ARMO-R / 1250-9 / 18,5 - 4A	1455	1250	18,5	34,5	89250	12
ARMO-R / 1250-9 / 22 - 4A	1460	1250	22	42,5	97650	14
ARMO-R / 1250-9 / 30 - 4A	1460	1250	30	55	114975	18
ARMO-R / 1250-9 / 37 - 4A	1470	1250	37	67	131250	22
ARMO-R / 1250-9 / 45 - 4A	1475	1250	45	80	138600	24

6 POLE TYPE	SPEED	DIAMETER	POWER	CURRENT	AIR FLOW	WING ANGLE
	r.p.m	mm	kW	230V - 400V	m ³ /h	
ARMO-R / 500-6 / 0,37 - 6A	900	500	0,37	1,1	8400	38
ARMO-R / 560-6 / 0,37 - 6A	900	560	0,37	1,1	10500	32
ARMO-R / 560-6 / 0,55 - 6A	930	560	0,55	1,5	11760	38
ARMO-R / 630-6 / 0,37 - 6A	900	630	0,37	1,1	11576	22
ARMO-R / 630-6 / 0,55 - 6A	930	630	0,55	1,5	13650	28
ARMO-R / 630-6 / 0,75 - 6A	945	630	0,75	2	14963	32
ARMO-R / 630-6 / 1,1 - 6A	945	630	1,1	2,9	16800	38
ARMO-R / 710-3 / 0,37 - 6A	900	710	0,37	1,1	13125	18
ARMO-R / 710-3 / 0,55 - 6A	930	710	0,55	1,5	16538	26
ARMO-R / 710-3 / 0,75 - 6A	945	710	0,75	2	18900	32
ARMO-R / 710-6 / 1,1 - 6A	945	710	1,1	2,9	11025	12
ARMO-R / 710-6 / 1,5 - 6A	945	710	1,5	3,6	13000	16
ARMO-R / 710-6 / 2,2 - 6A	950	710	2,2	5,4	13750	22
ARMO-R / 710-6 / 3 - 6A	950	710	3	6,9	18900	28
ARMO-R / 710-6 / 4 - 6A	955	710	4	9	21000	32
ARMO-R / 800-6 / 0,55 - 6A	930	800	0,55		13125	10
ARMO-R / 800-6 / 1,1 - 6A	945	800	1,1	2,9	22050	22
ARMO-R / 800-6 / 1,5 - 6A	945	800	1,5	3,6	25200	26
ARMO-R / 800-6 / 2,2 - 6A	950	800	2,2	5,4	28350	32
ARMO-R / 800-9 / 0,75 - 6A	945	800	0,75	2	14700	14
ARMO-R / 800-9 / 1,1 - 6A	945	800	1,1	2,9	19950	20
ARMO-R / 800-9 / 1,5 - 6A	945	800	1,5	3,6	23100	24
ARMO-R / 800-9 / 2,2 - 6A	950	800	2,2	5,4	27300	30
ARMO-R / 800-9 / 3 - 6A	950	800	3	6,9	28350	32
ARMO-R / 900-6 / 1,1 - 6A	945	900	1,1	2,9	23100	14
ARMO-R / 900-6 / 1,5 - 6A	945	900	1,5	3,6	25200	16
ARMO-R / 900-6 / 2,2 - 6A	950	900	2,2	5,4	31500	22
ARMO-R / 900-6 / 3 - 6A	950	900	3	6,9	36750	28
ARMO-R / 900-6 / 4 - 6A	955	900	4	9	40950	32
ARMO-R / 900-9 / 1,5 - 6A	945	900	1,5	3,6	23100	14
ARMO-R / 900-9 / 2,2 - 6A	950	900	2,2	5,4	27300	20
ARMO-R / 900-9 / 3 - 6A	950	900	3	6,9	35700	24
ARMO-R / 900-9 / 4 - 6A	955	900	4	9	39900	30
ARMO-R / 900-9 / 5,5 - 6A	985	900	5,5	12,3	43050	32
ARMO-R / 1000-6 / 1,5 - 6A	945	1000	1,5	3,6	26250	10
ARMO-R / 1000-6 / 2,2 - 6A	950	1000	2,2	5,4	34650	16
ARMO-R / 1000-6 / 3 - 6A	950	1000	3	6,9	44100	22
ARMO-R / 1000-6 / 4 - 6A	955	1000	4	9	49350	26
ARMO-R / 1000-6 / 5,5 - 6A	985	1000	5,5	12,3	55650	32
ARMO-R / 1000-9 / 2,2 - 6A	950	1000	2,2	5,4	32550	14
ARMO-R / 1000-9 / 3 - 6A	950	1000	3	6,9	39900	20
ARMO-R / 1000-9 / 4 - 6A	955	1000	4	9	43050	22
ARMO-R / 1000-9 / 5,5 - 6A	985	1000	5,5	12,3	52500	28
ARMO-R / 1000-9 / 7,5 - 6A	960	1000	7,5	15	57750	32
ARMO-R / 1250-6 / 4 - 6A	955	1250	4	9	60900	12
ARMO-R / 1250-6 / 5,5 - 6A	985	1250	5,5	12,3	63300	16
ARMO-R / 1250-6 / 7,5 - 6A	960	1250	7,5	15	76650	20
ARMO-R / 1250-6 / 11 - 6A	960	1250	11	22	92400	26
ARMO-R / 1250-6 / 15 - 6A	965	1250	15	29	105000	32
ARMO-R / 1250-9 / 7,5 - 6A	960	1250	7,5	15	73500	16
ARMO-R / 1250-9 / 11 - 6A	960	1250	11	22	88200	22
ARMO-R / 1250-9 / 15 - 6A	965	1250	15	29	105000	28
ARMO-R / 1250-9 / 18,5 - 6A	970	1250	18,5	36,5	115500	32

Accessories



BSC-F



BSST

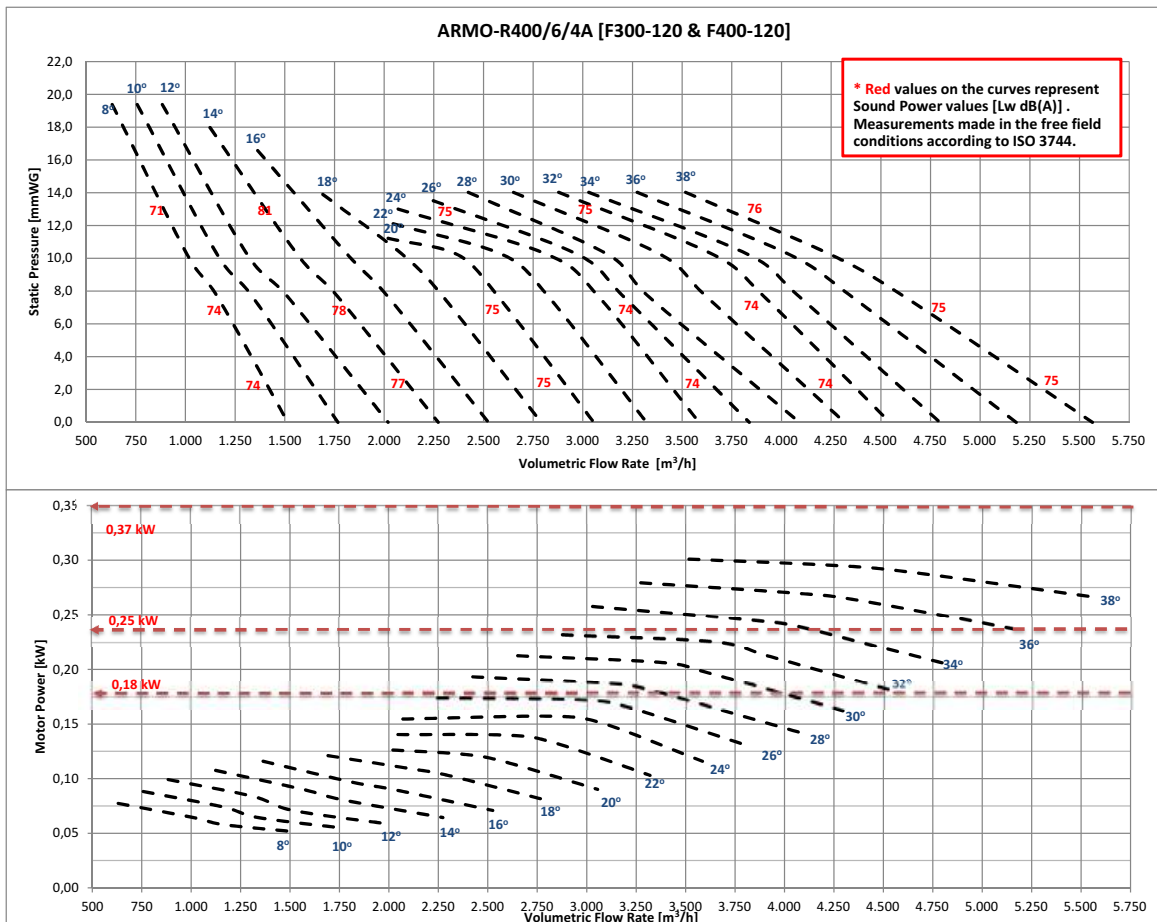
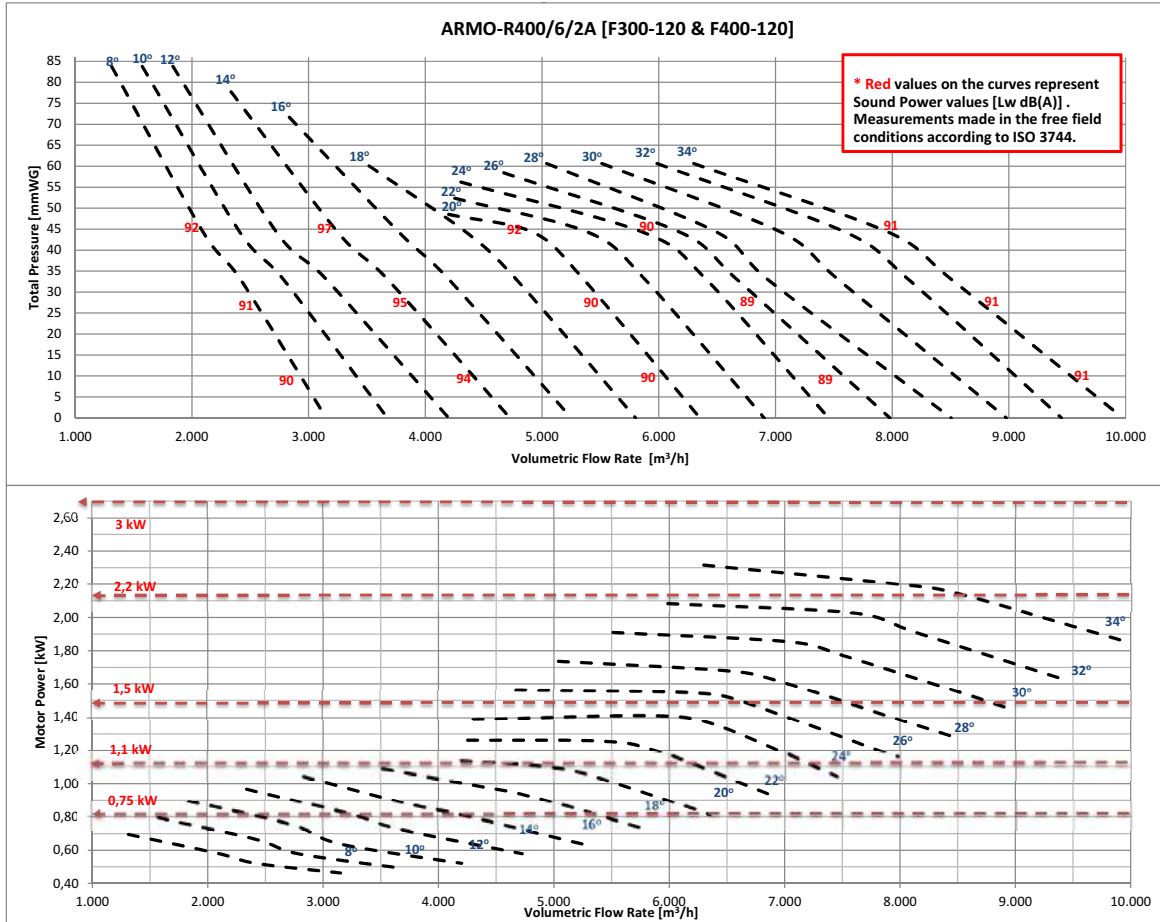

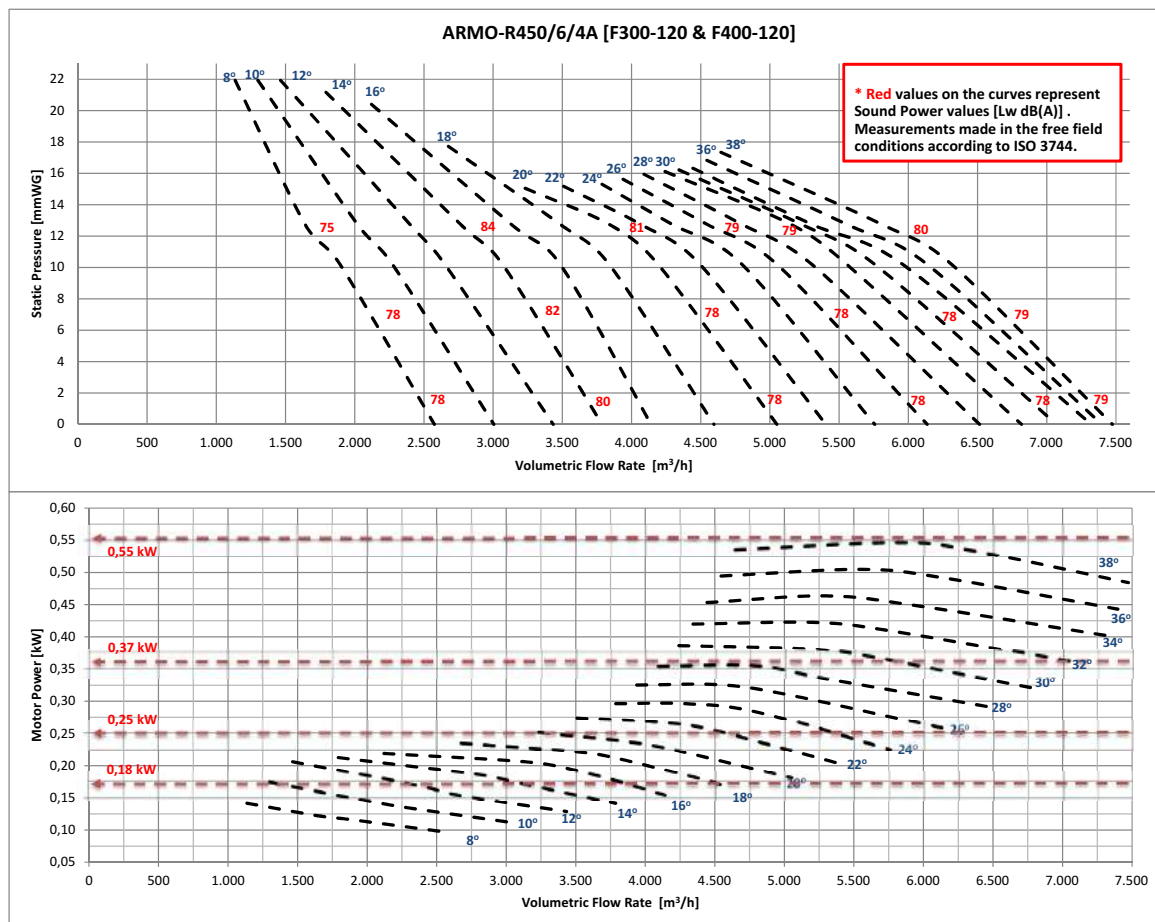
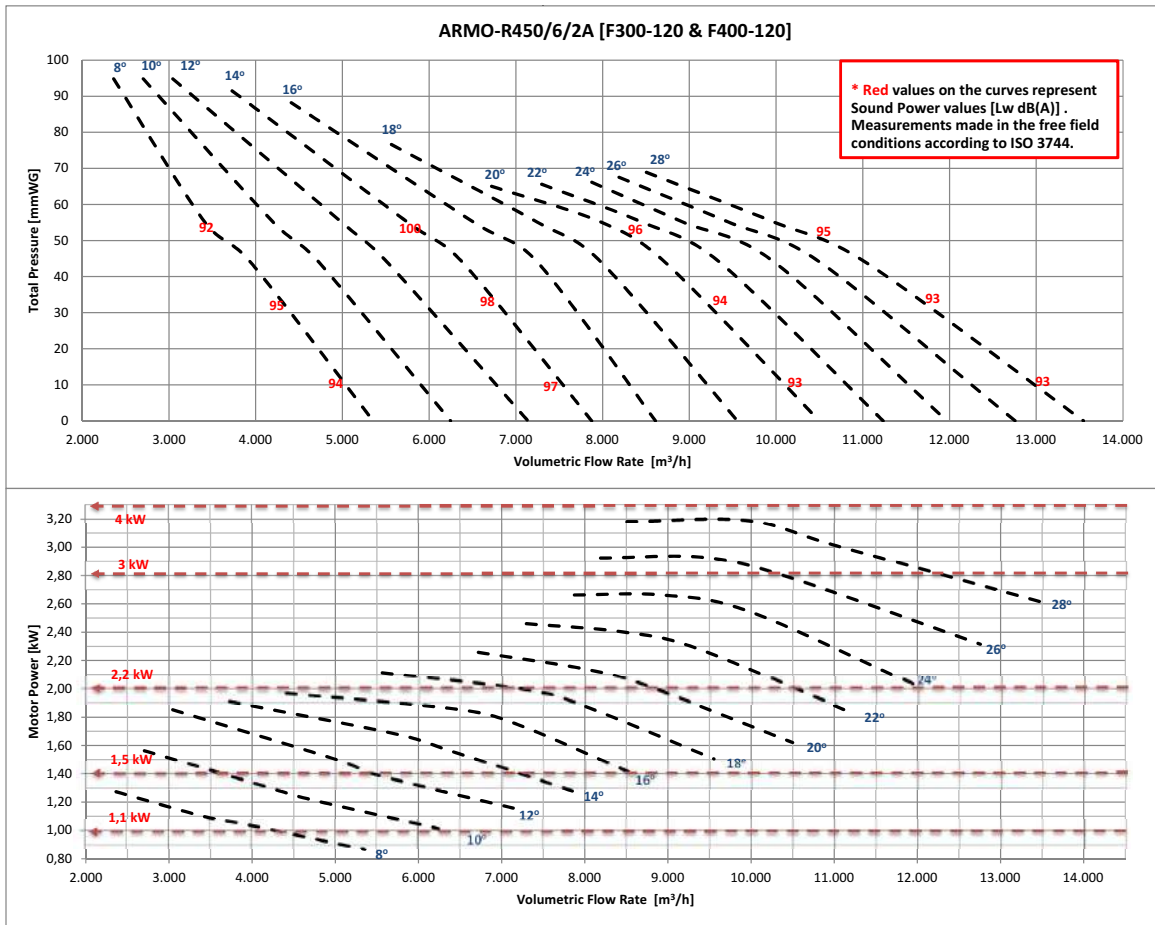

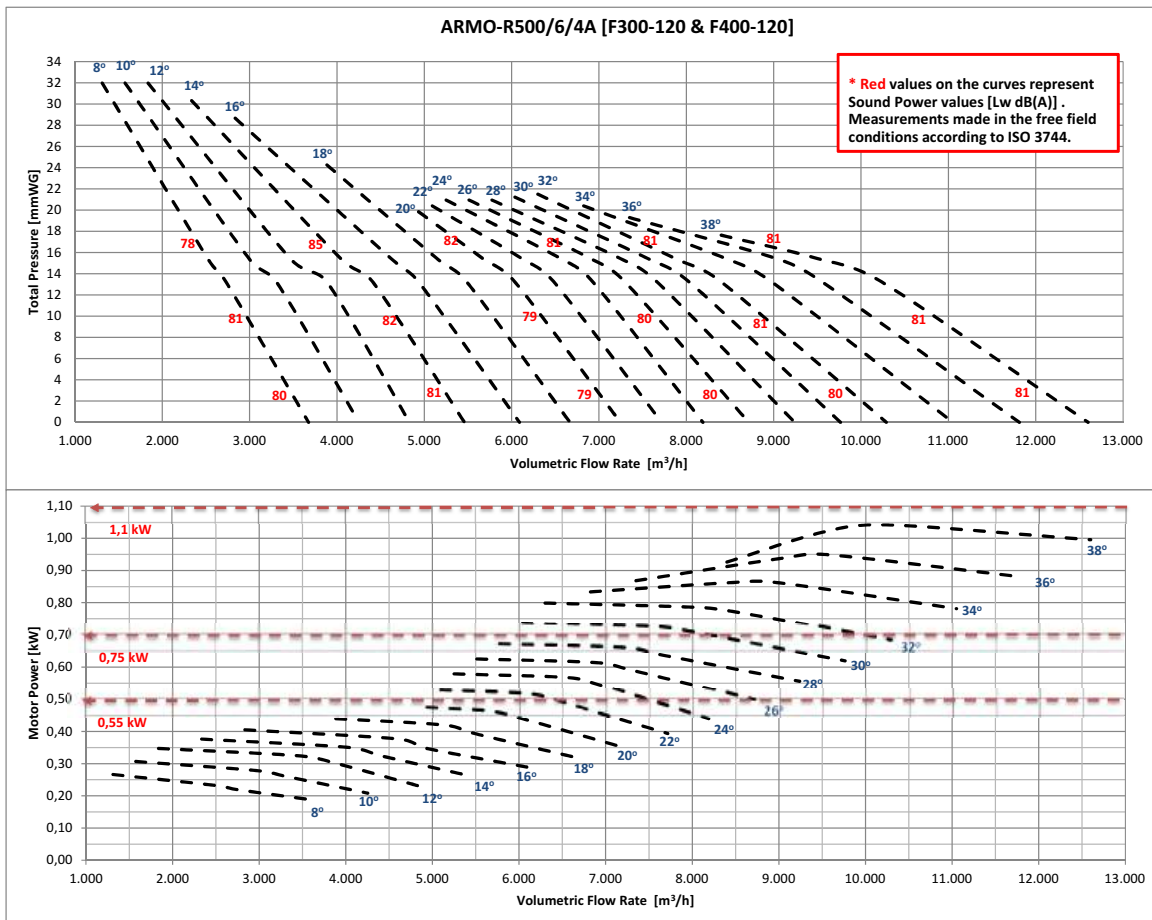
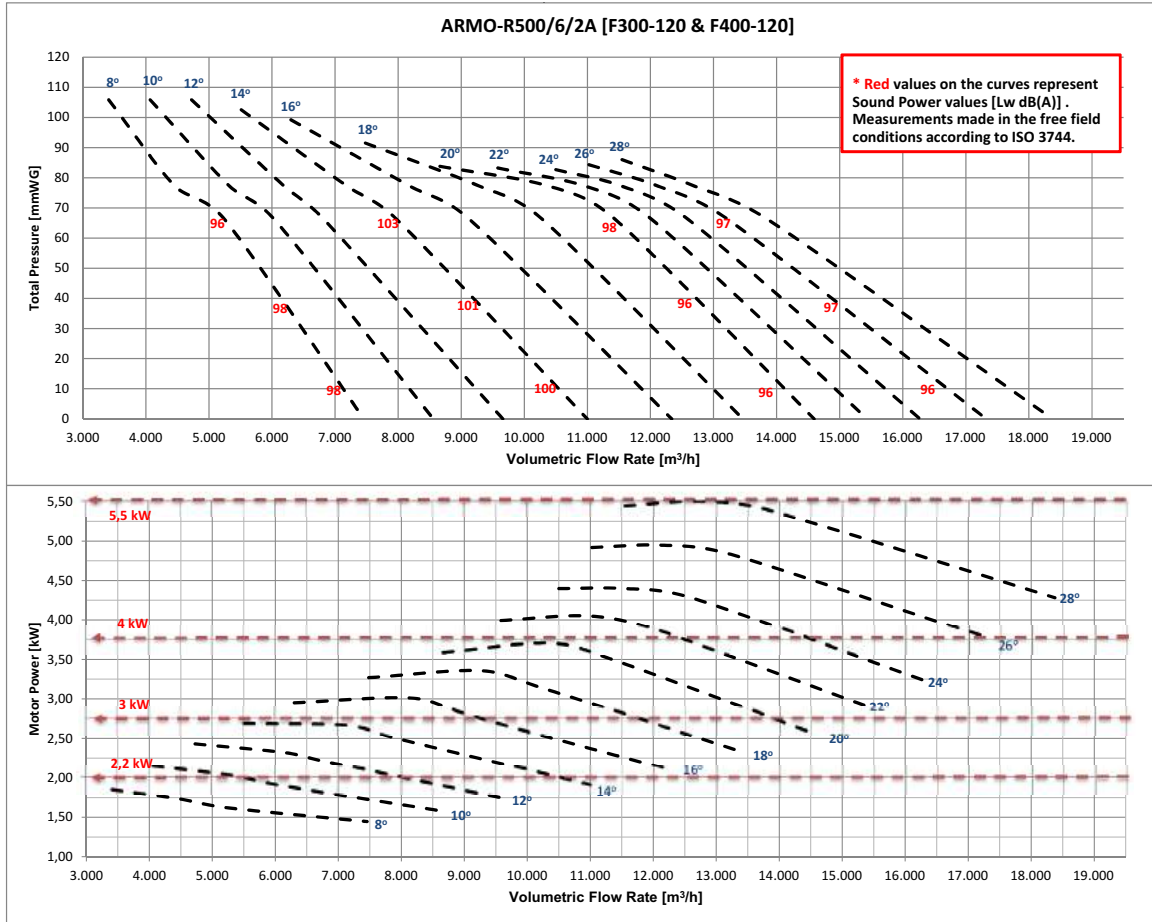

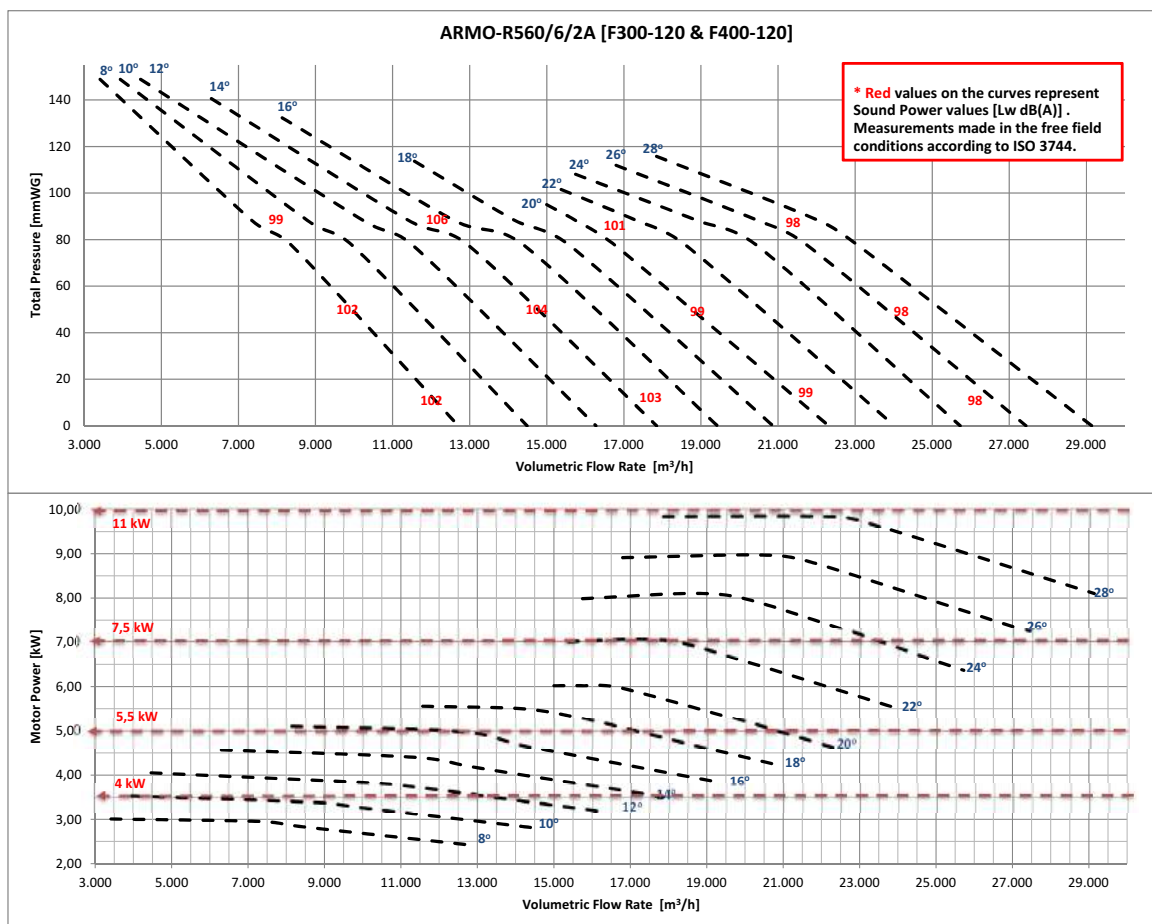
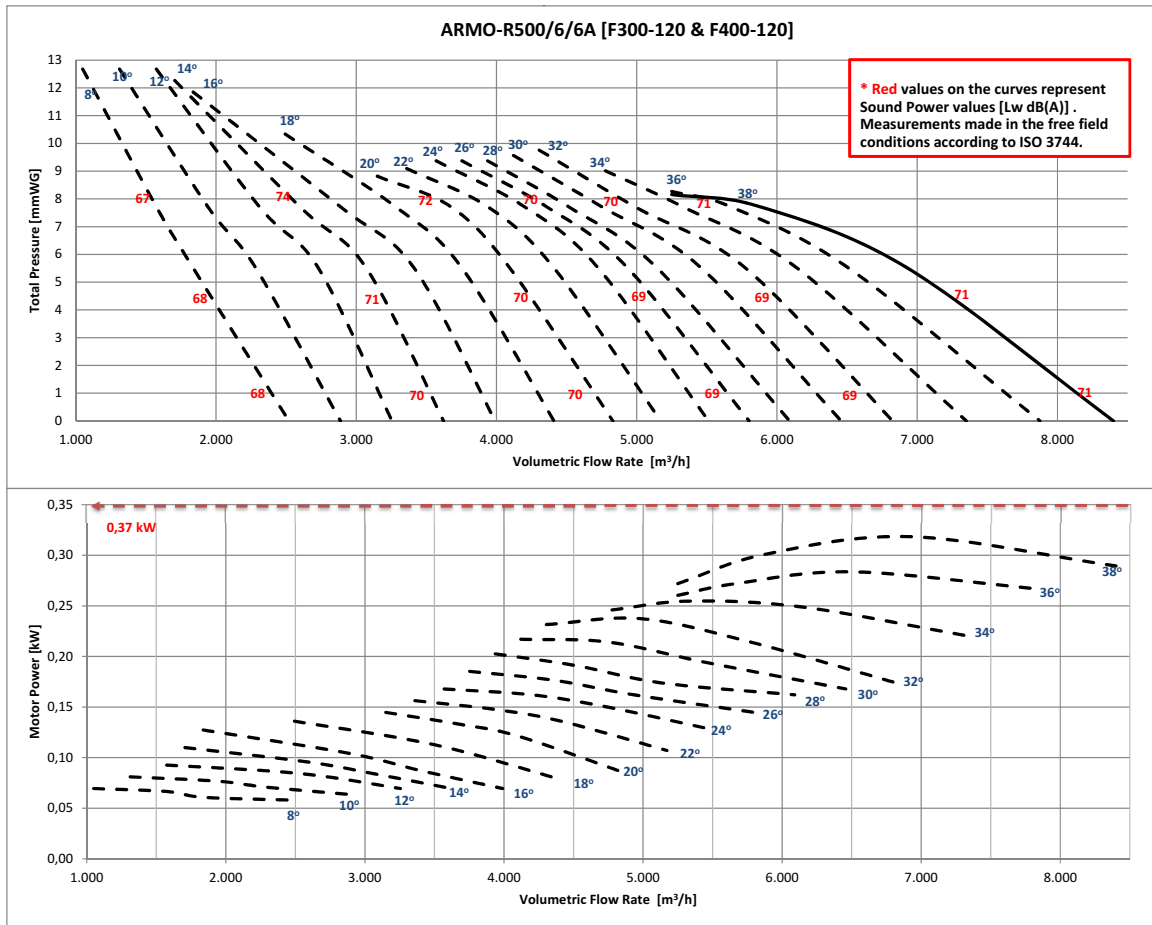

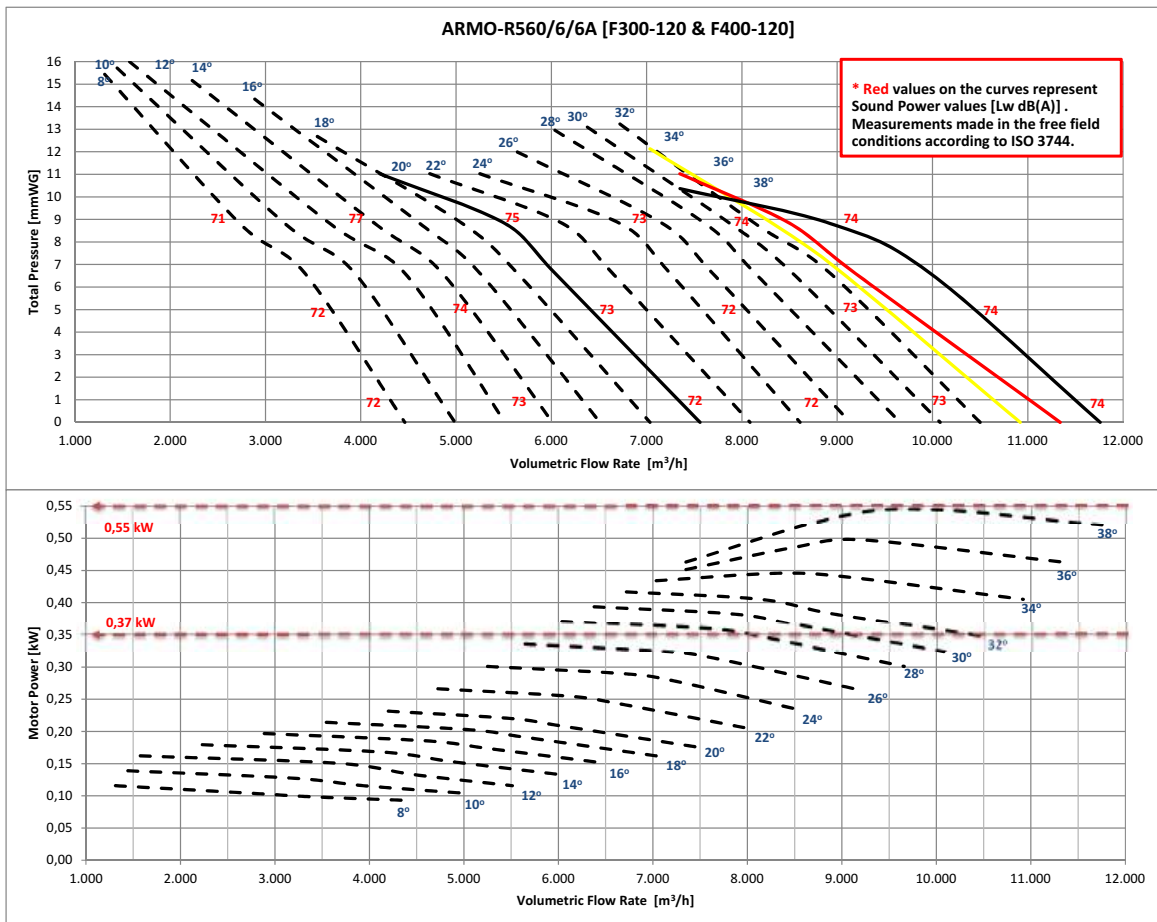
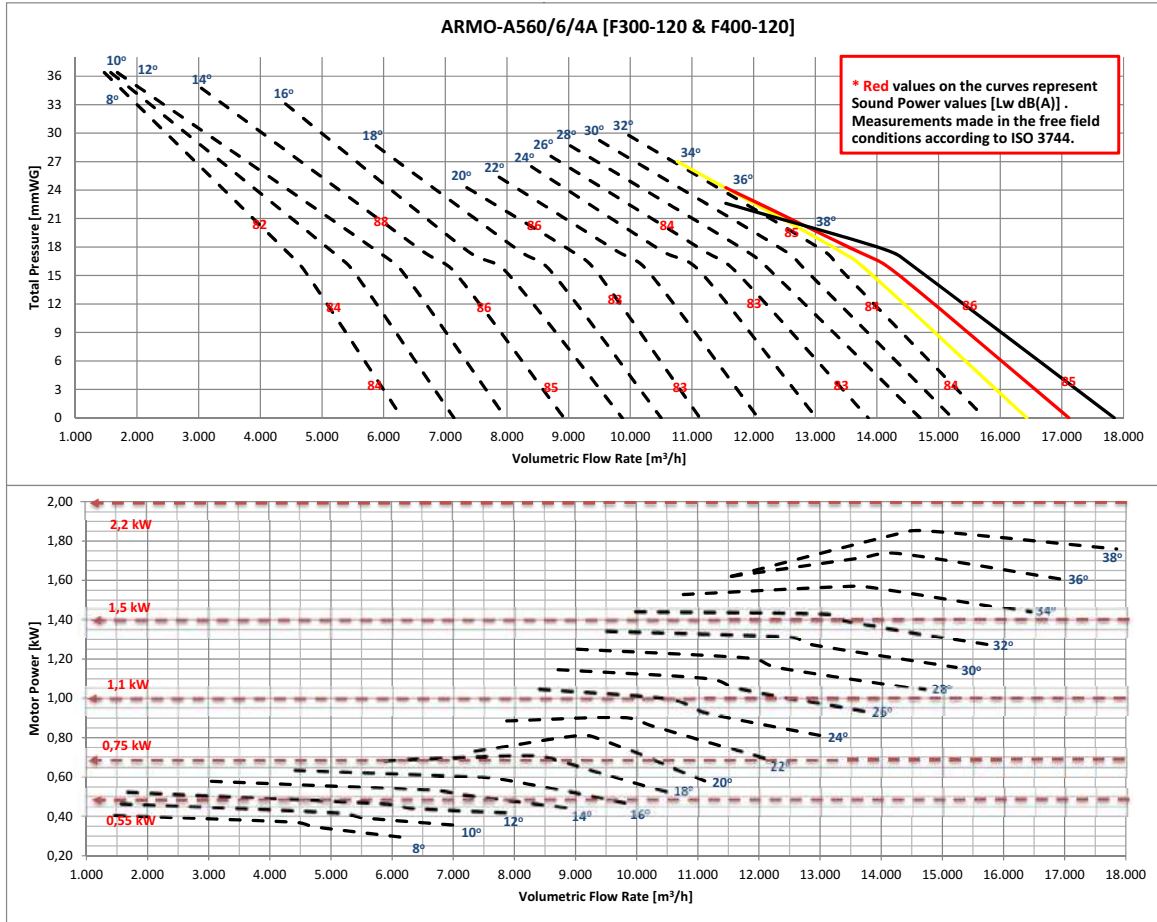

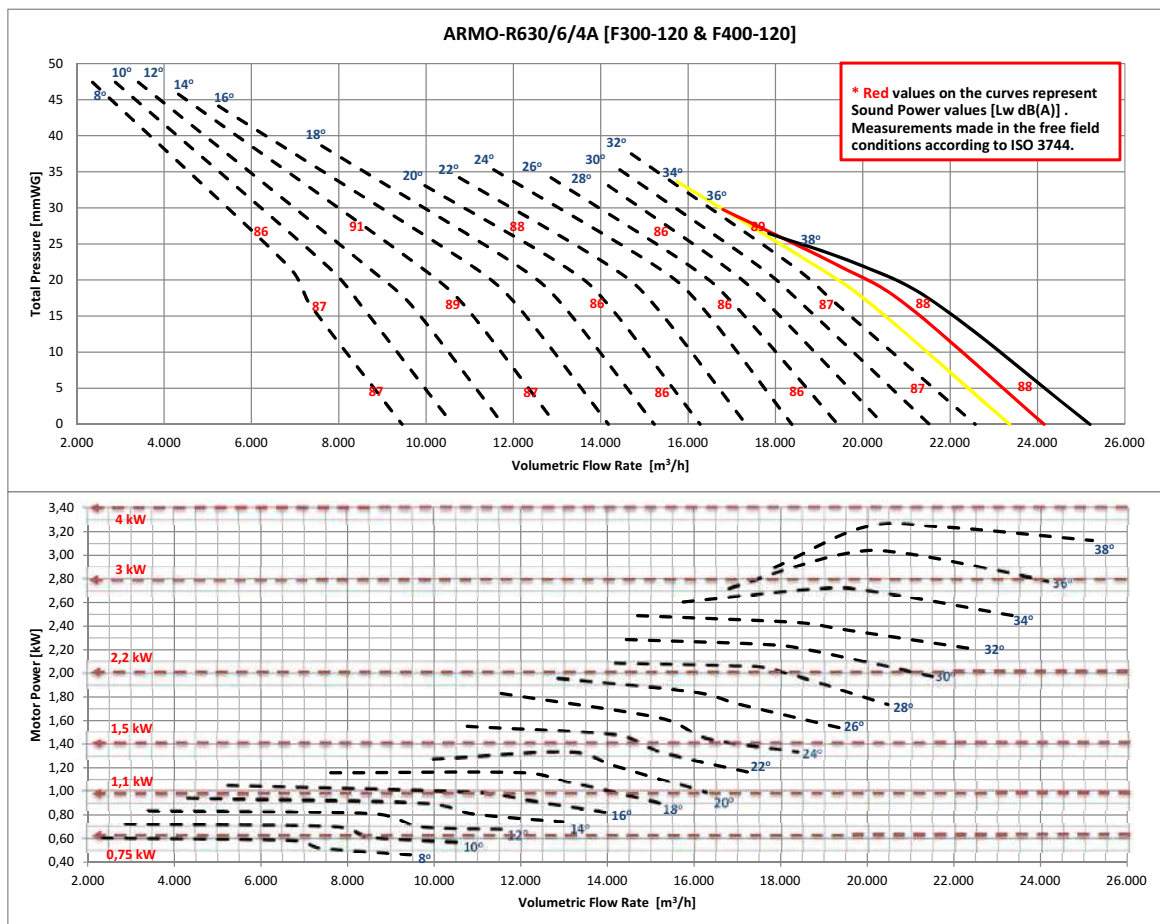
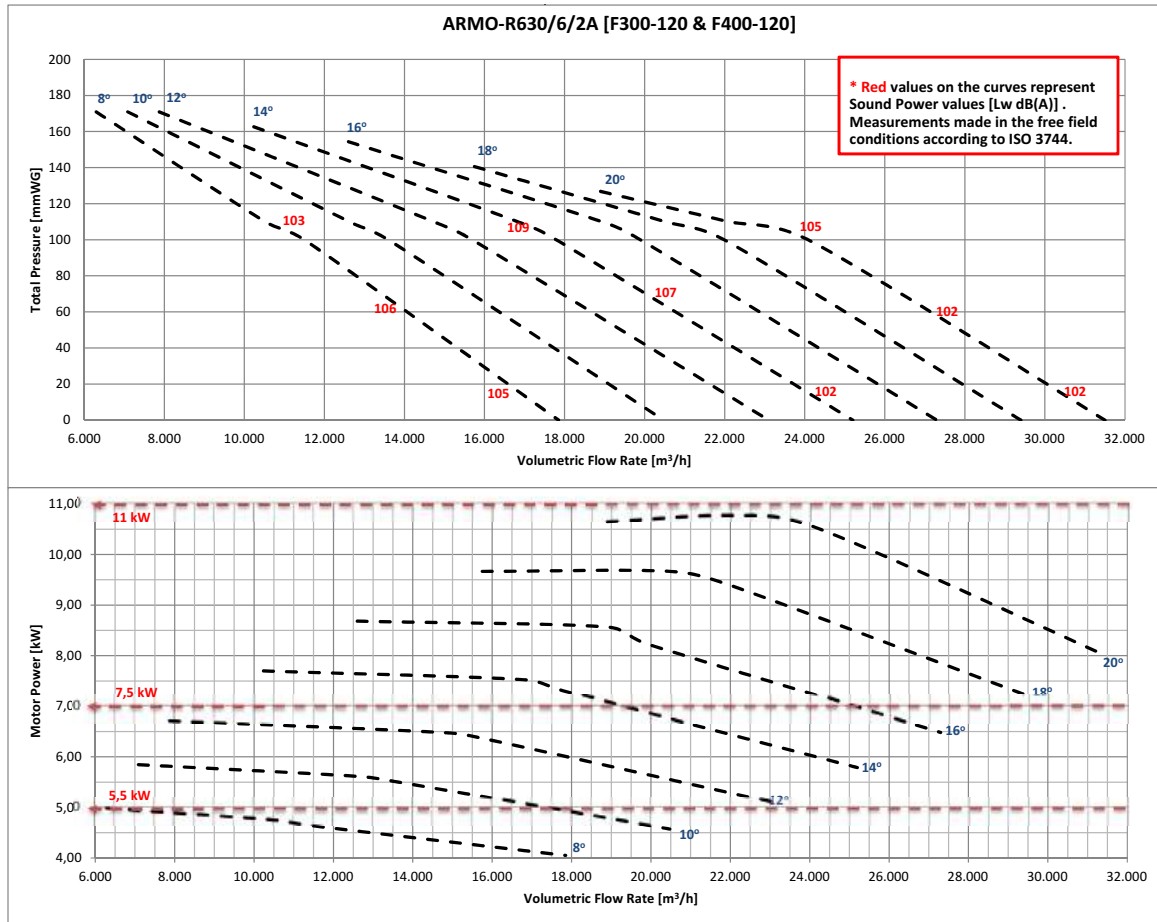

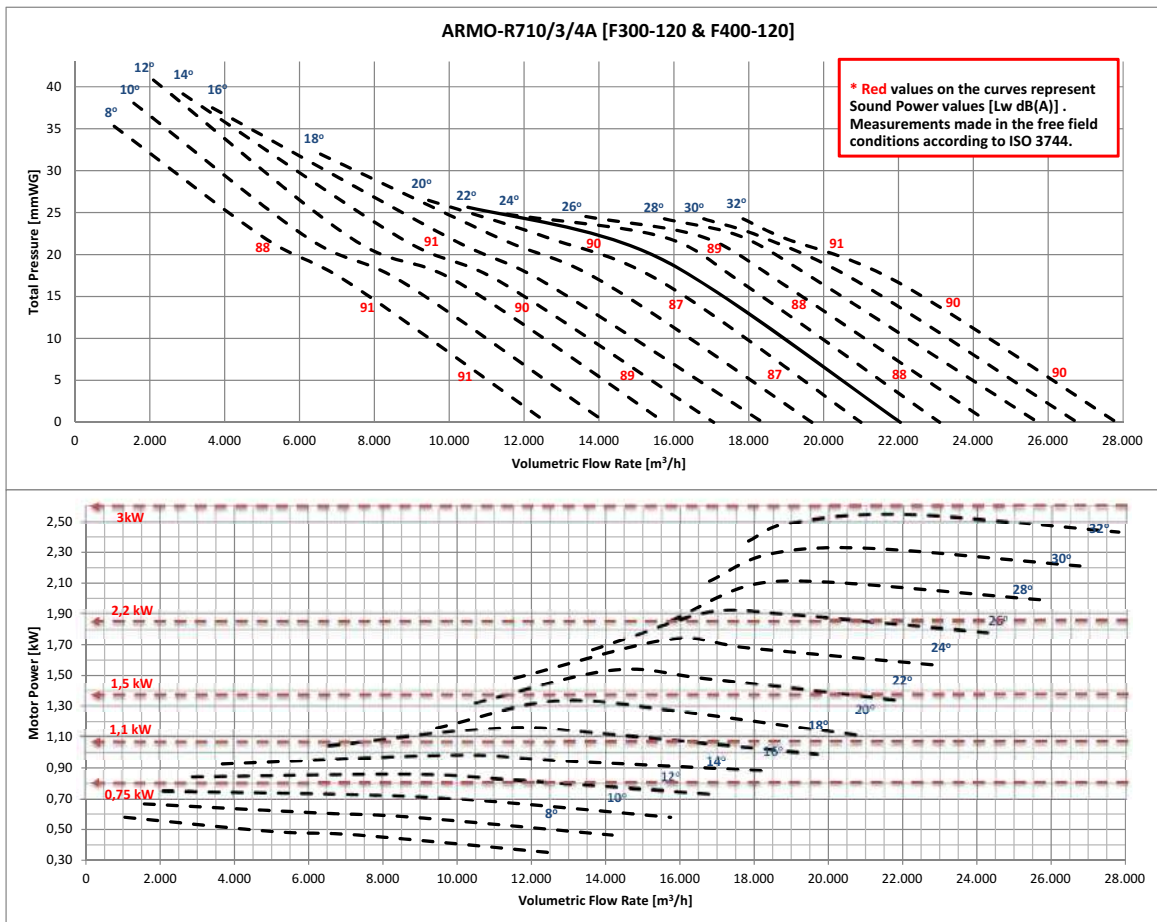
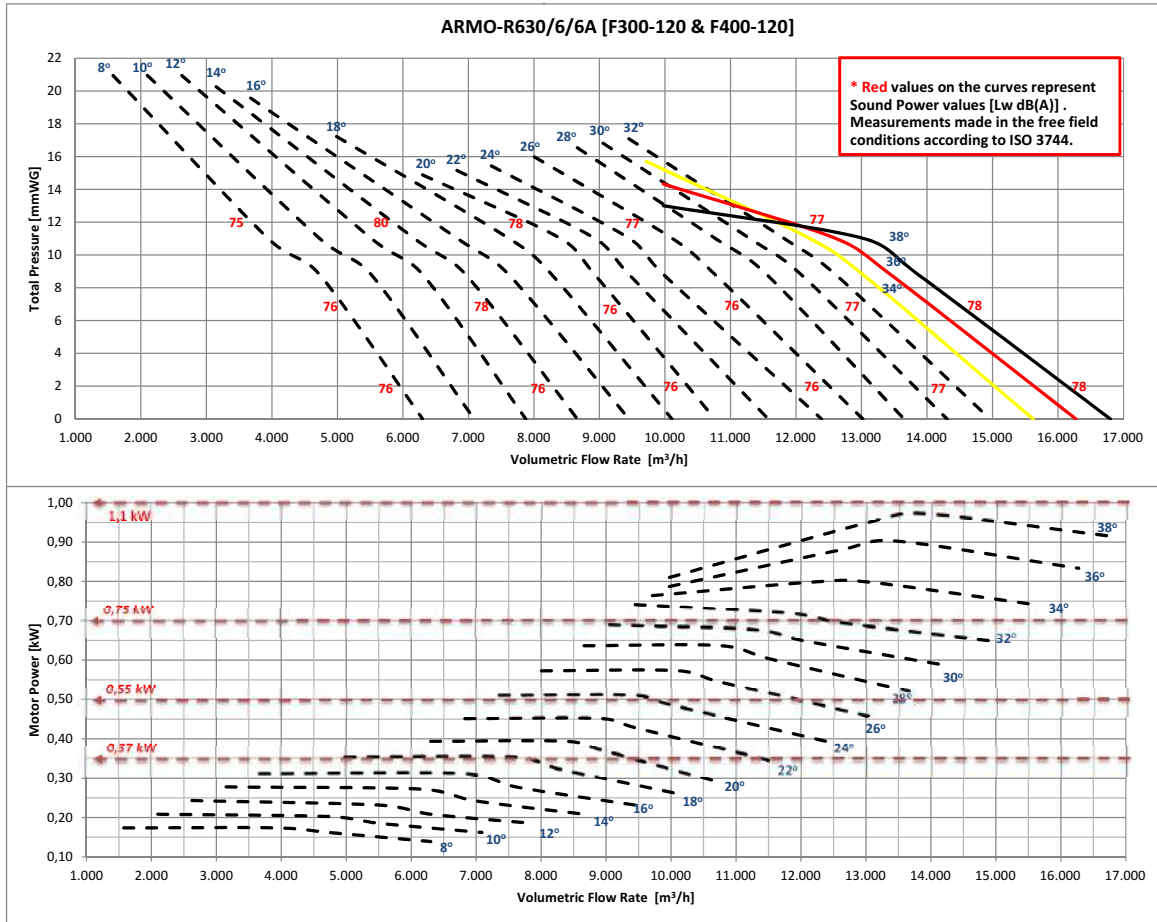

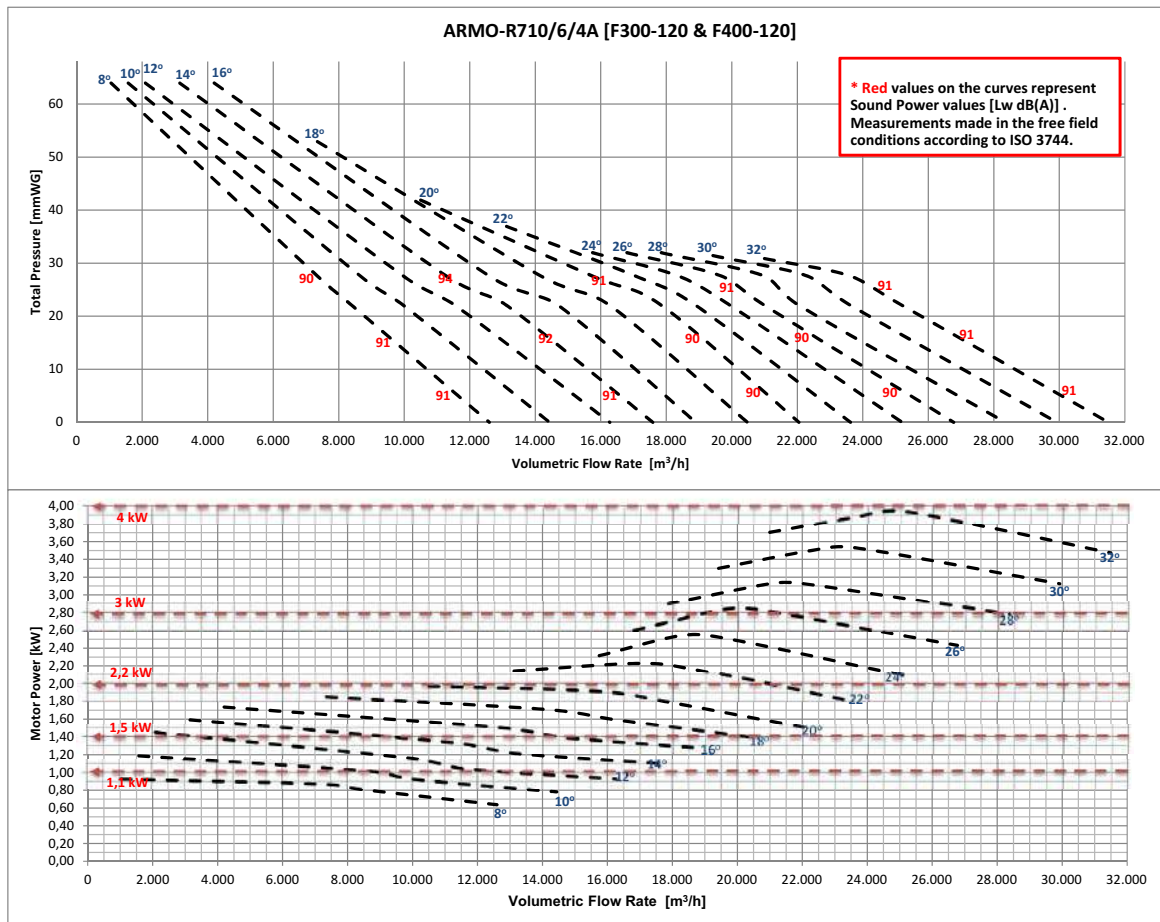
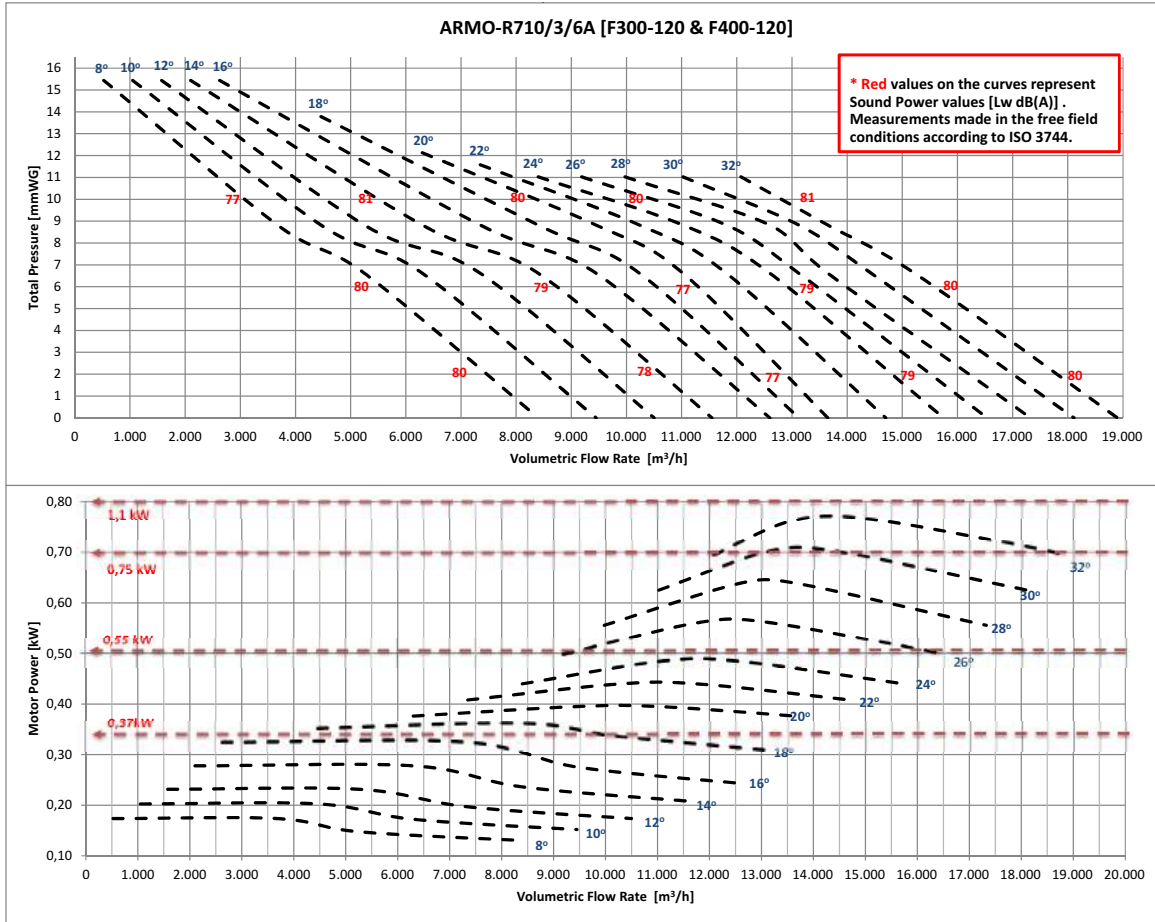

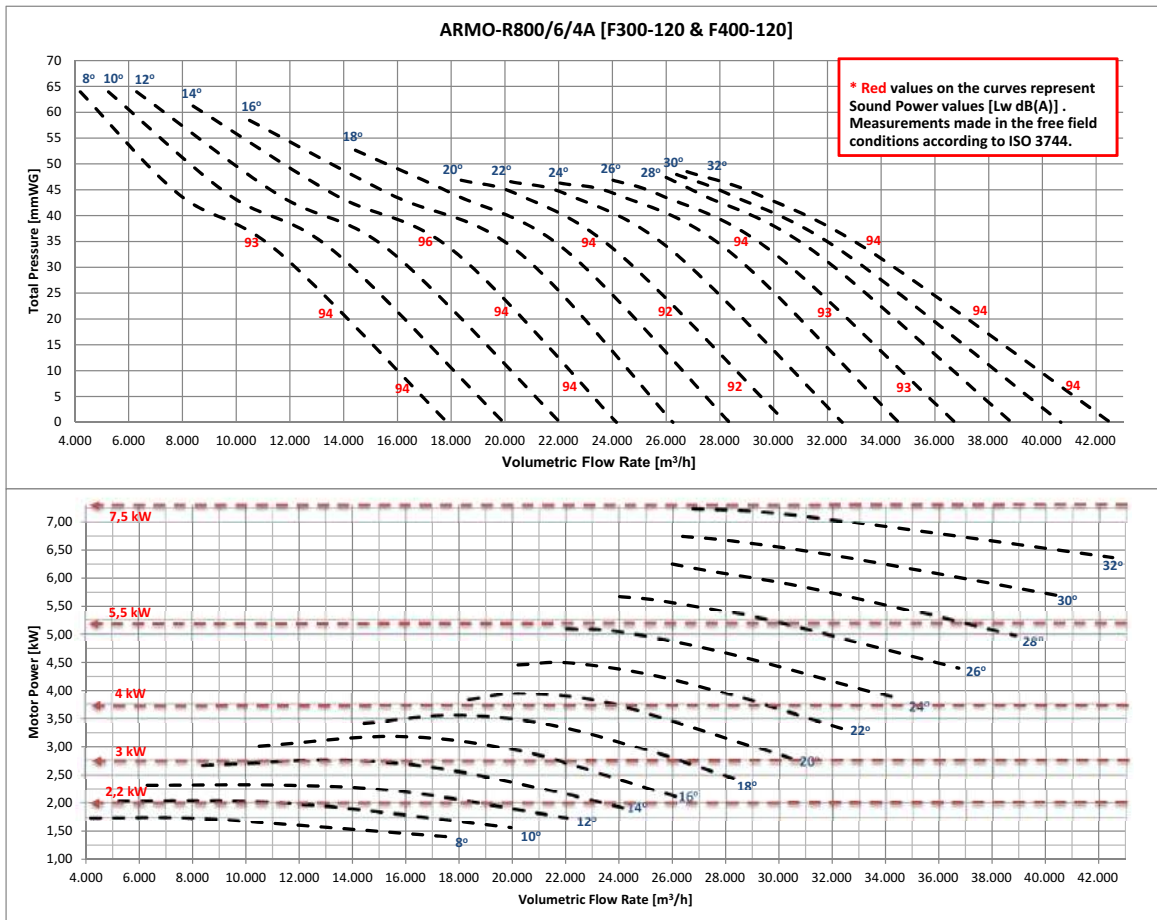
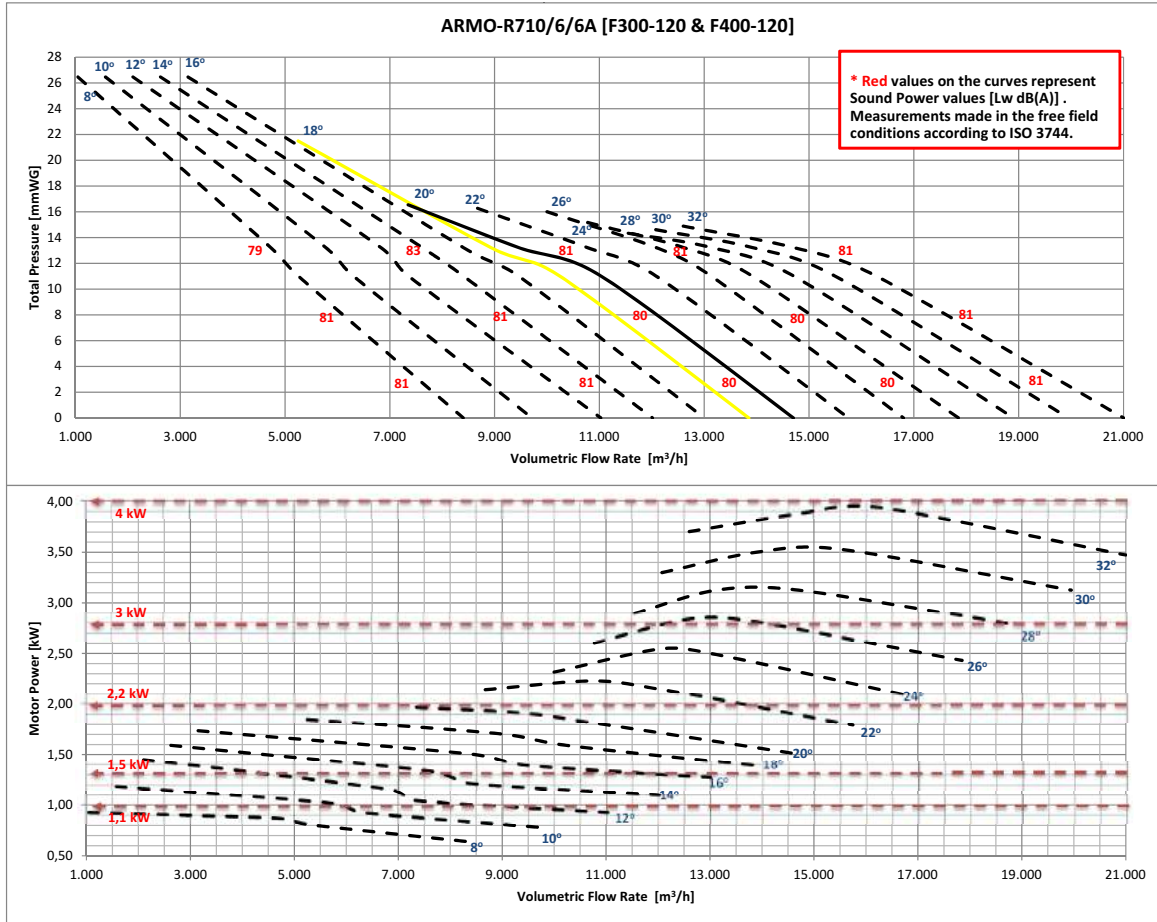

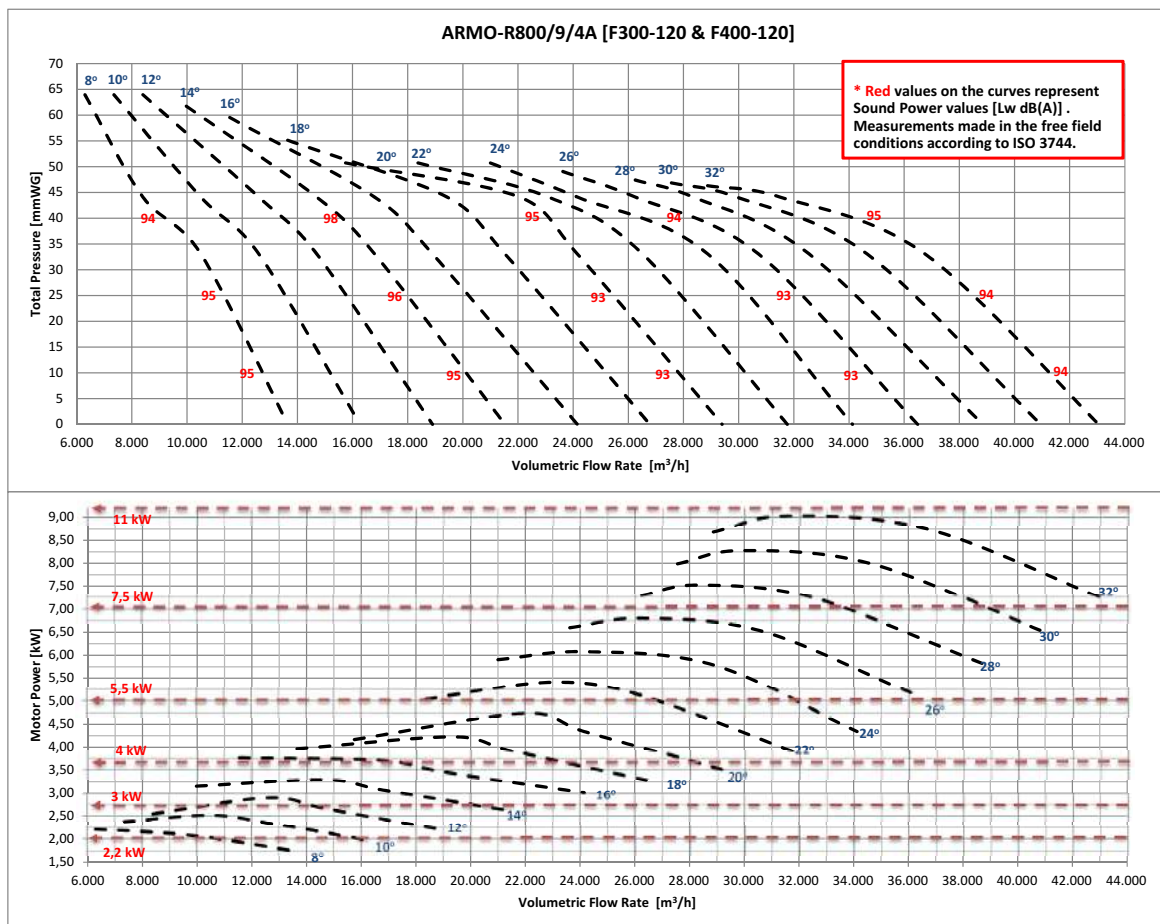
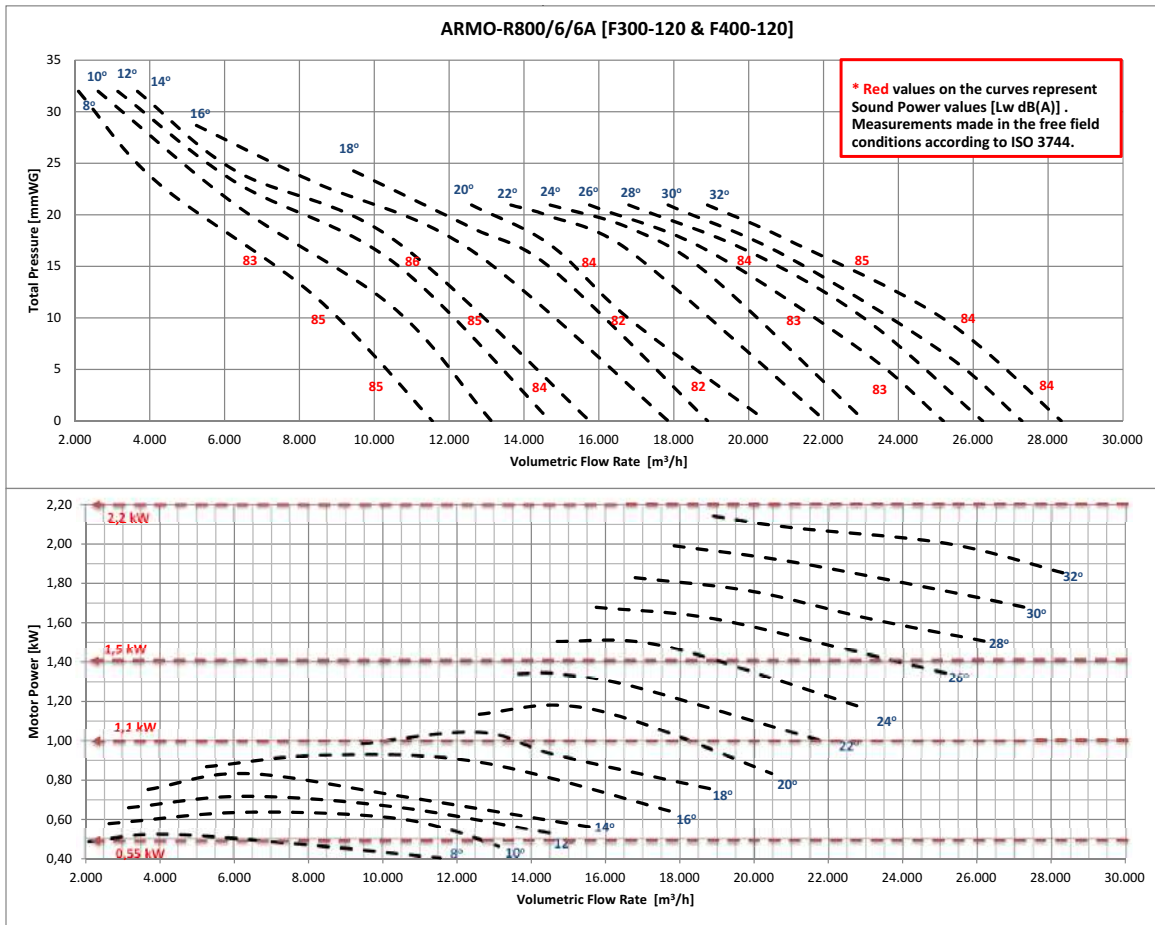

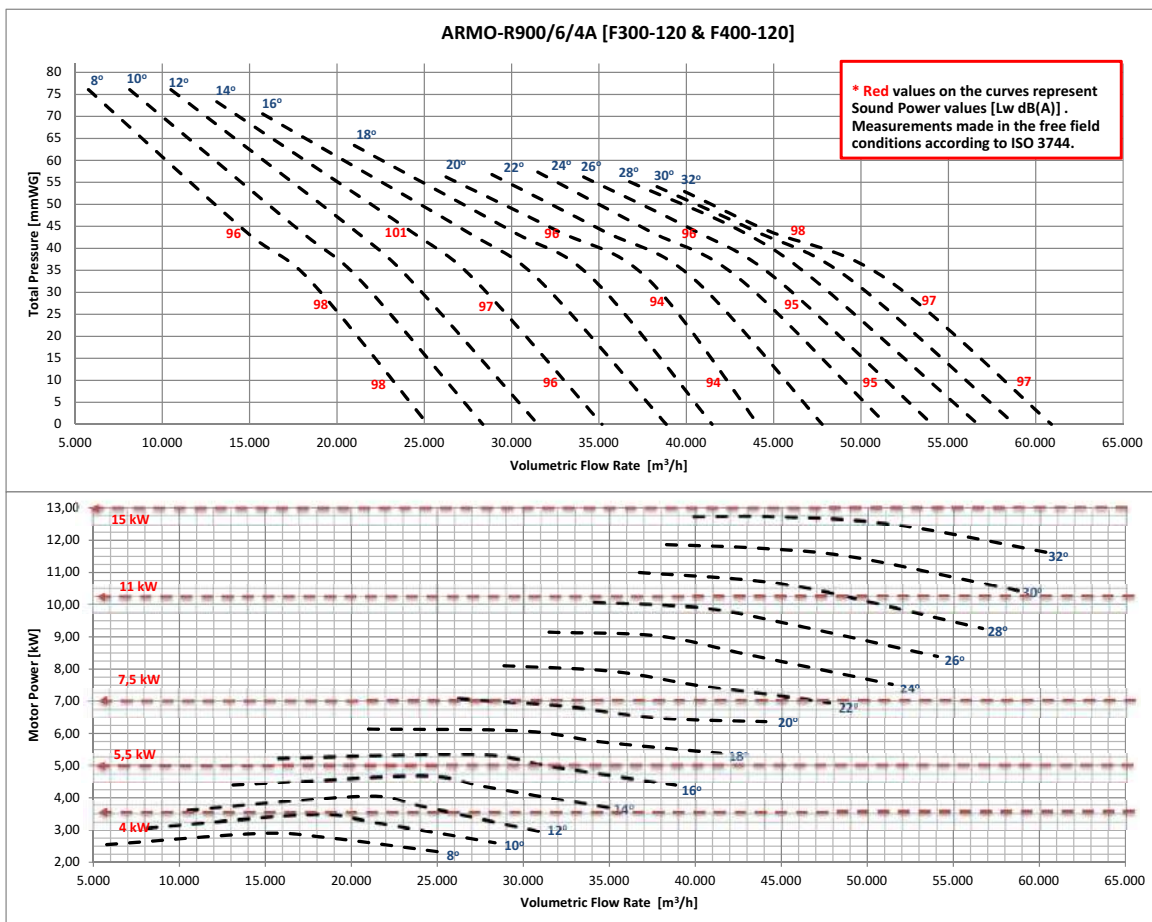
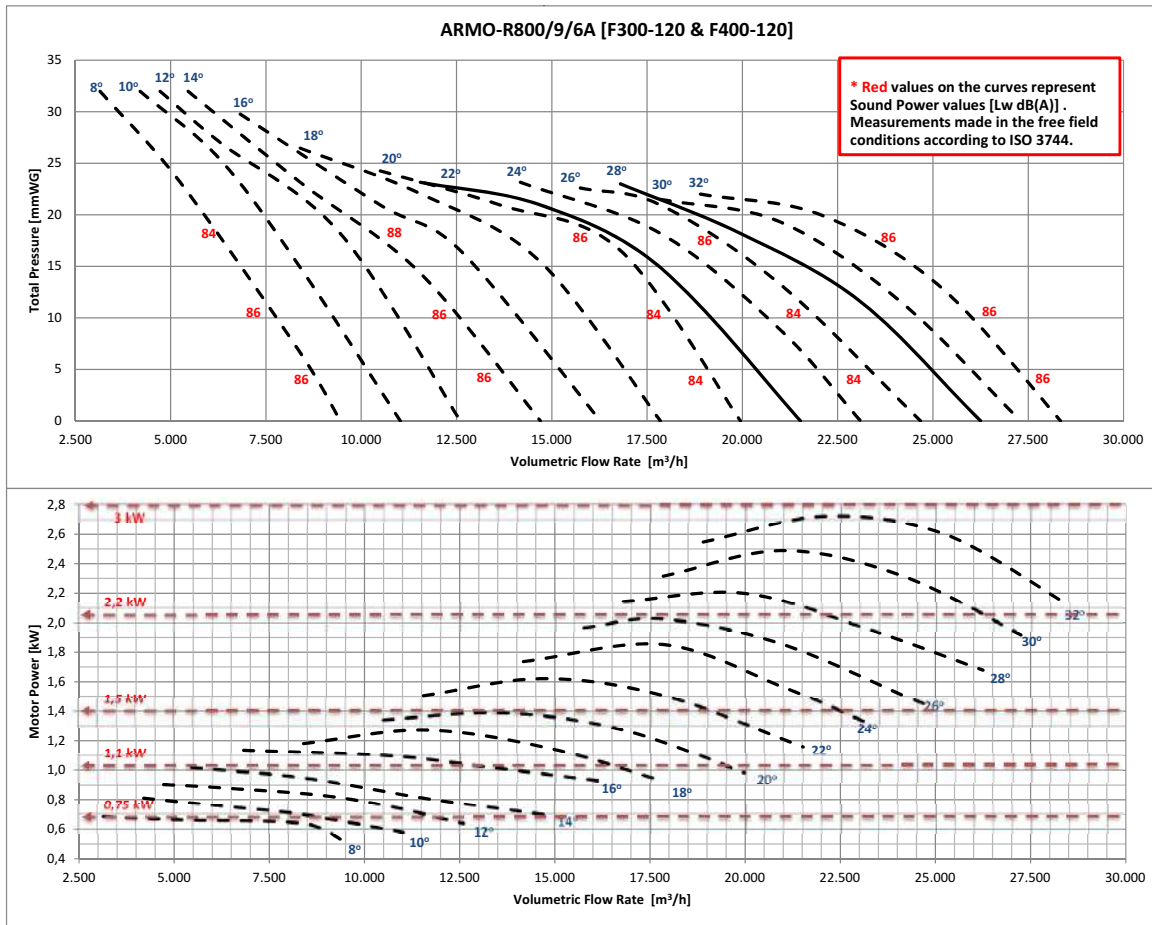

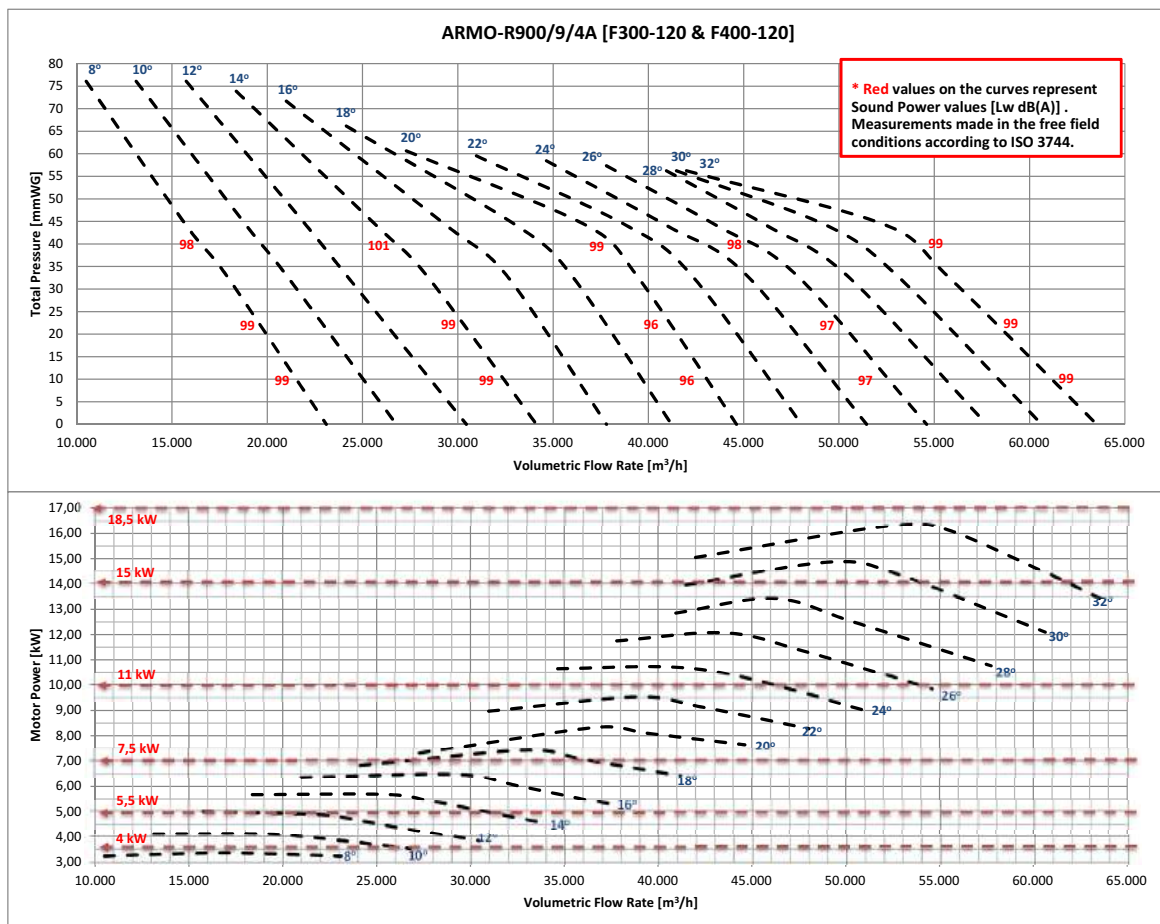
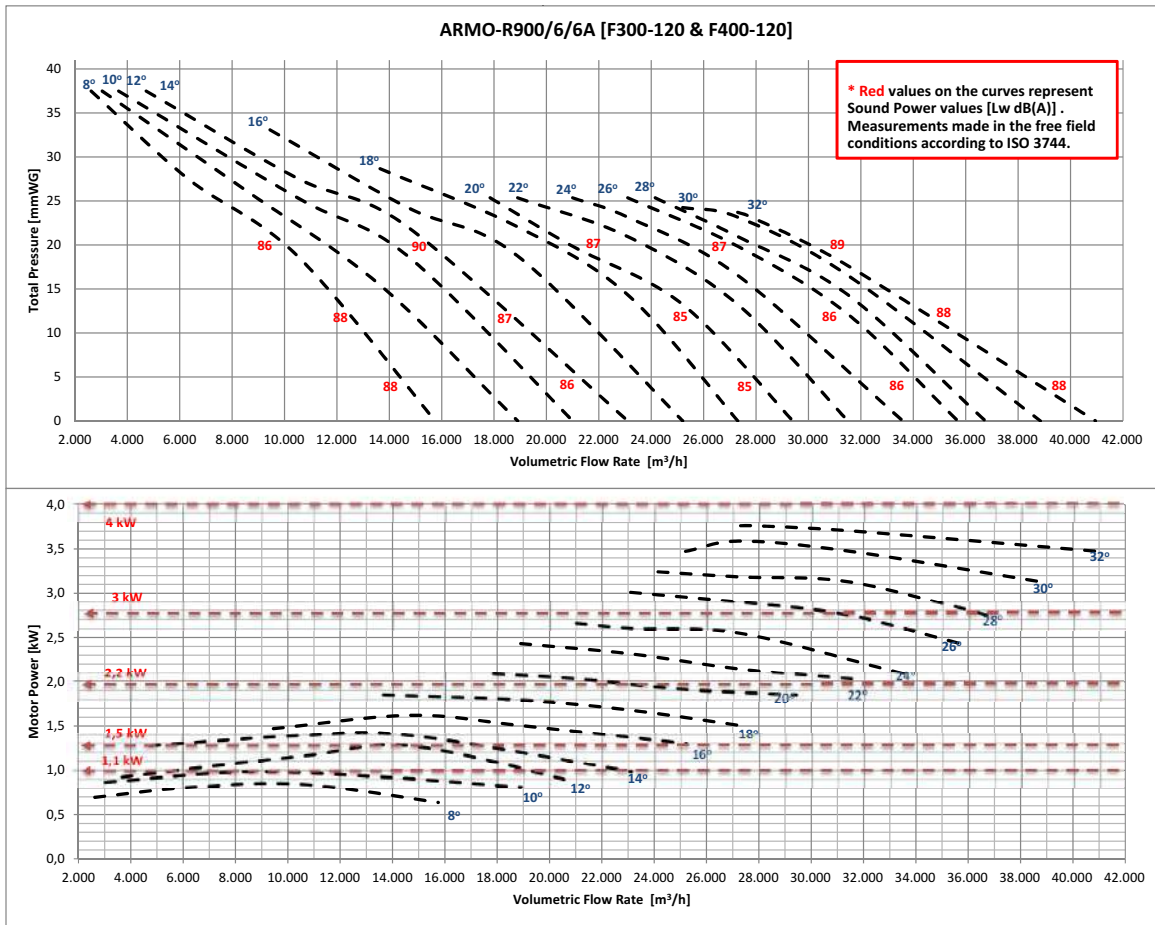

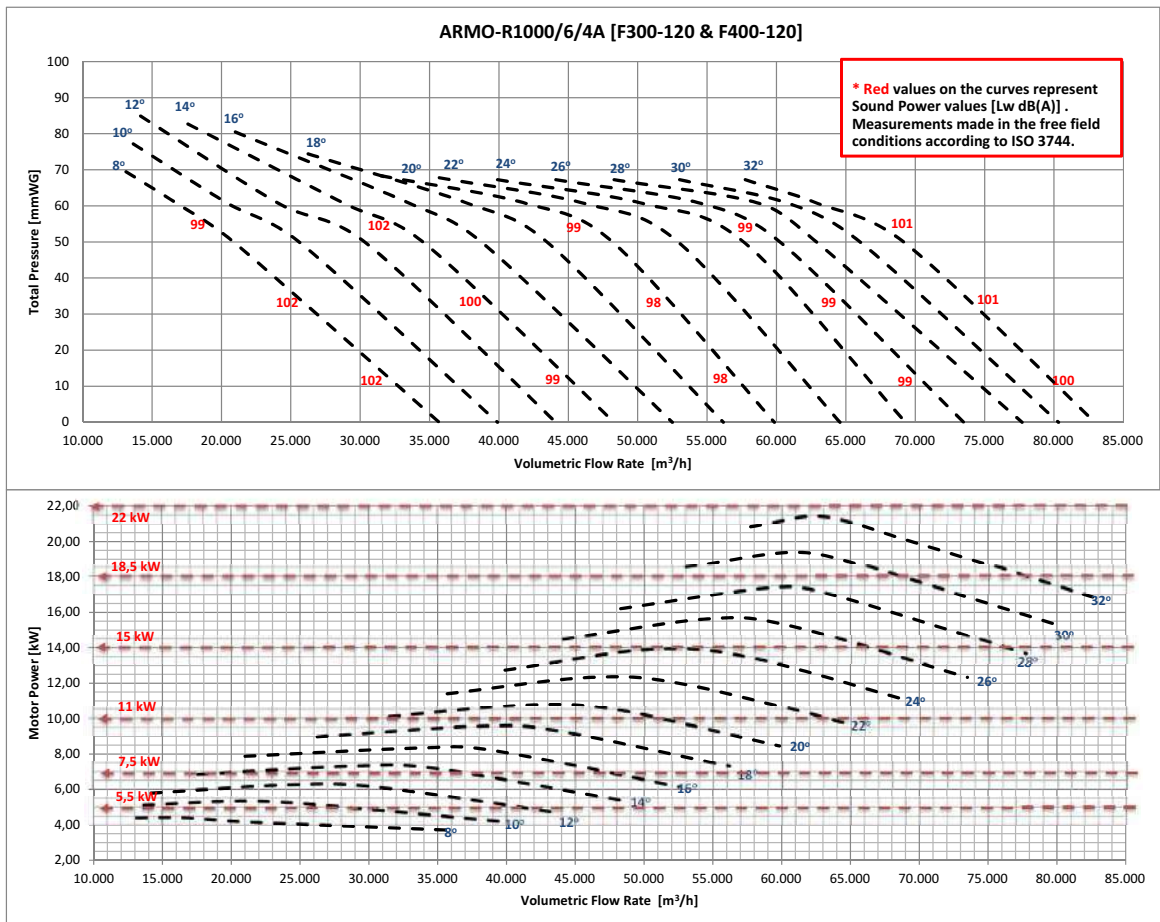
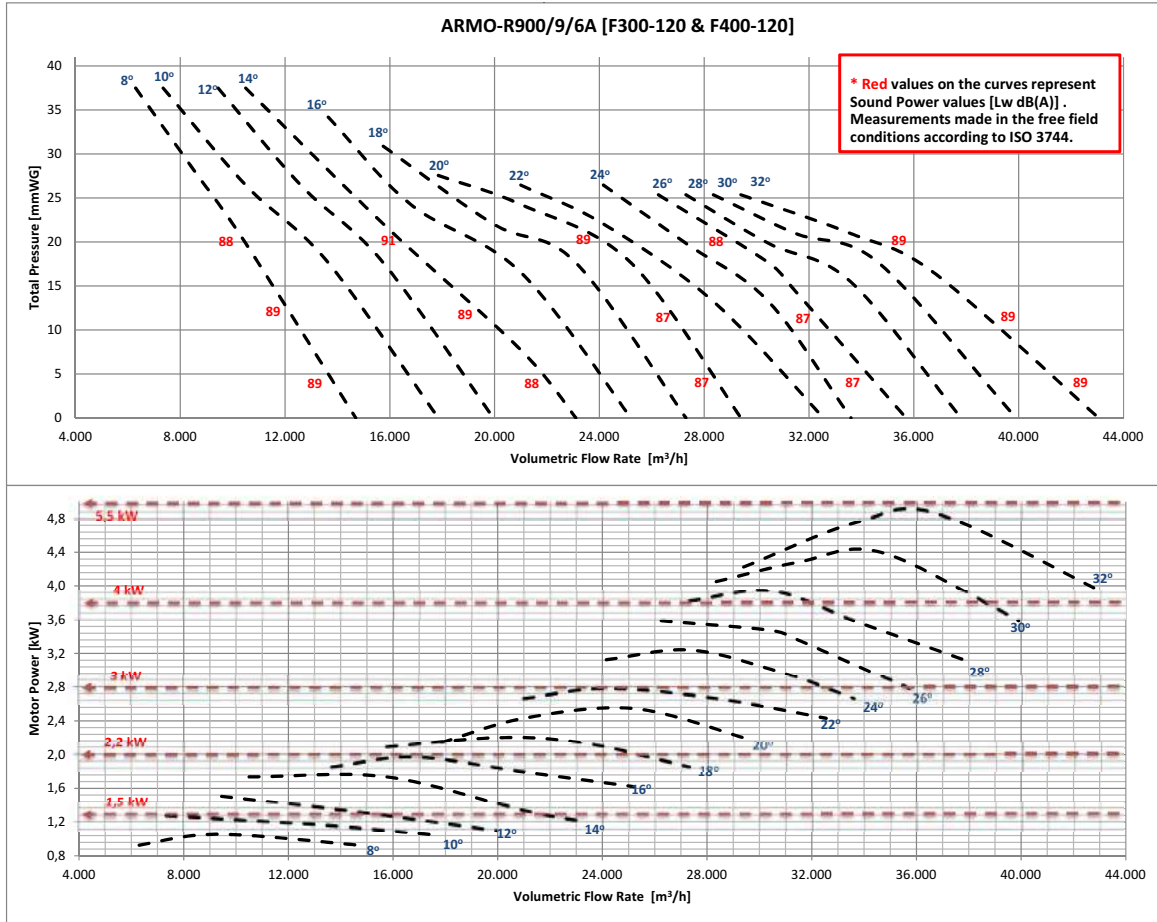

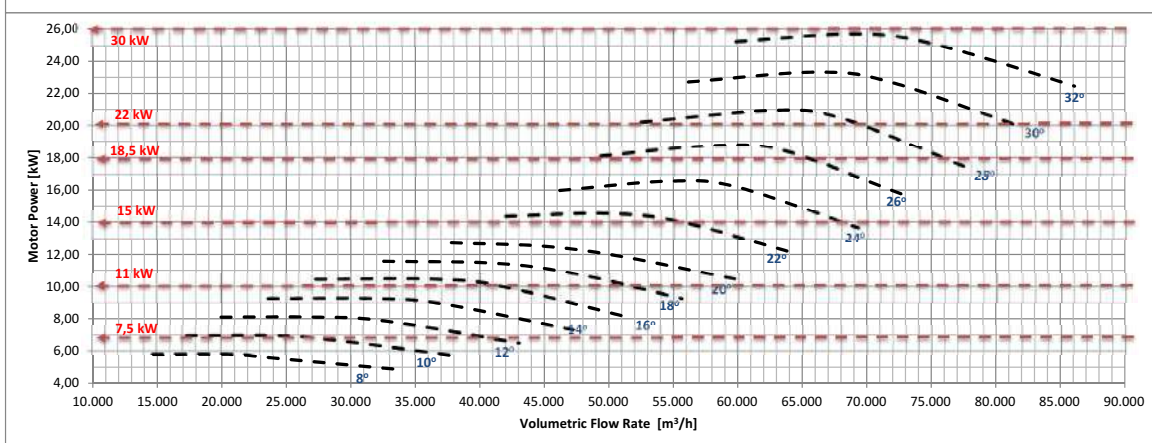
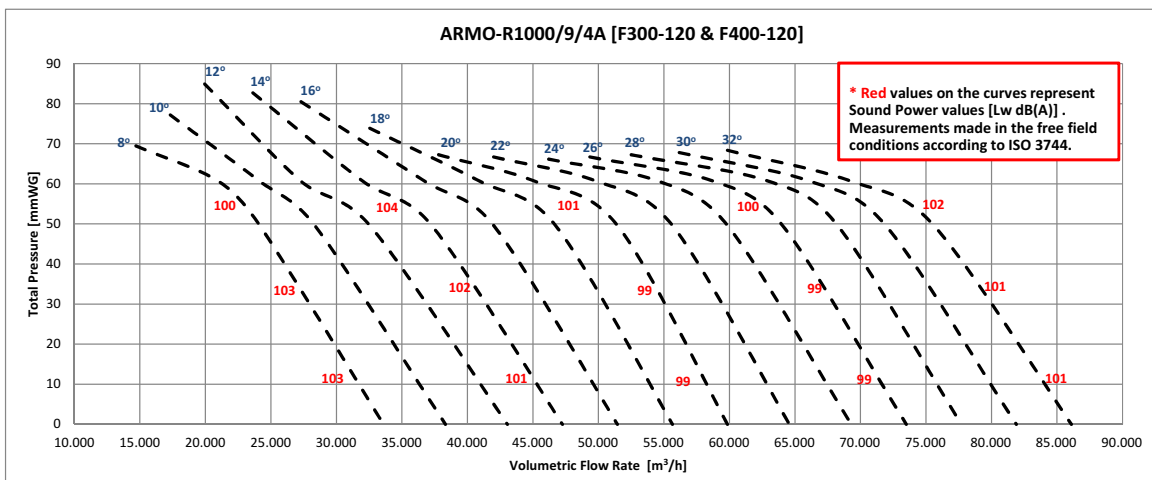
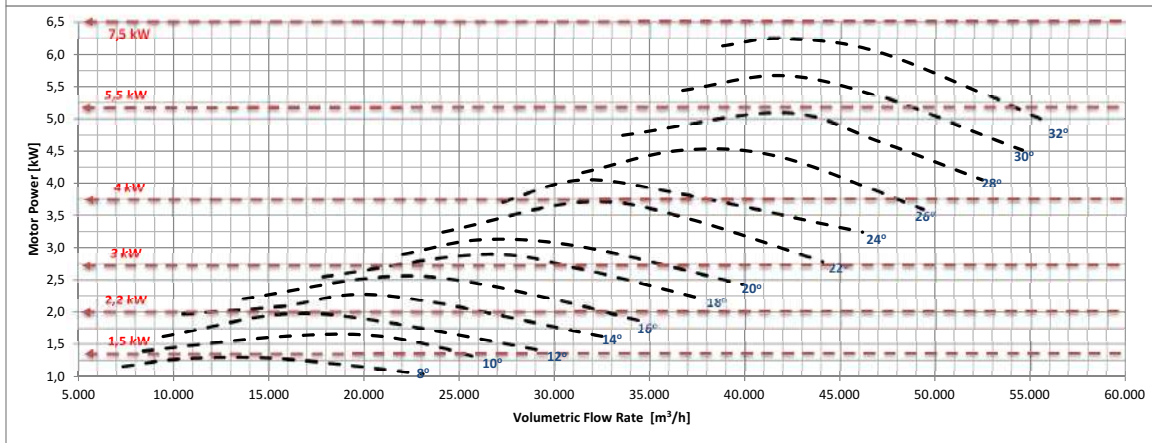
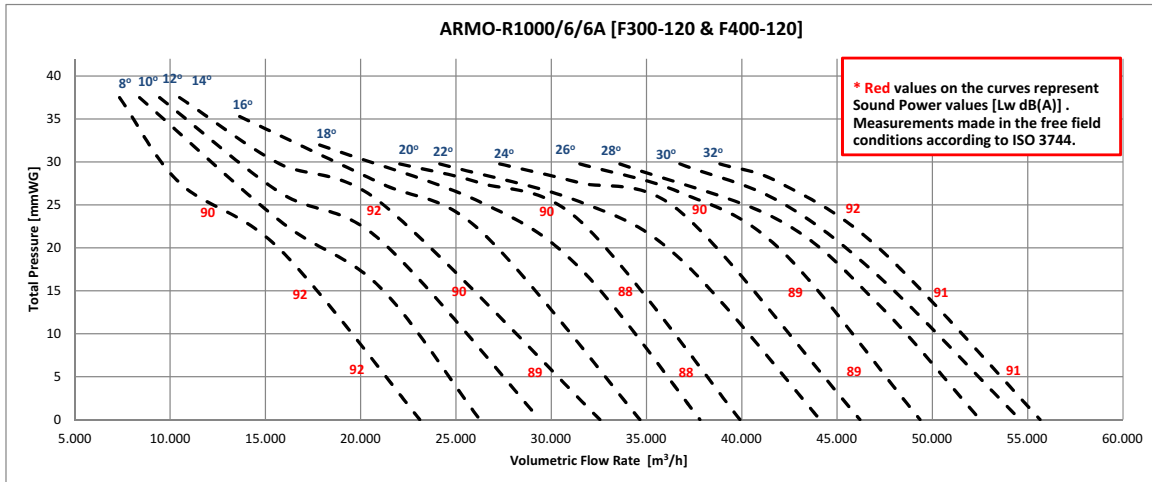

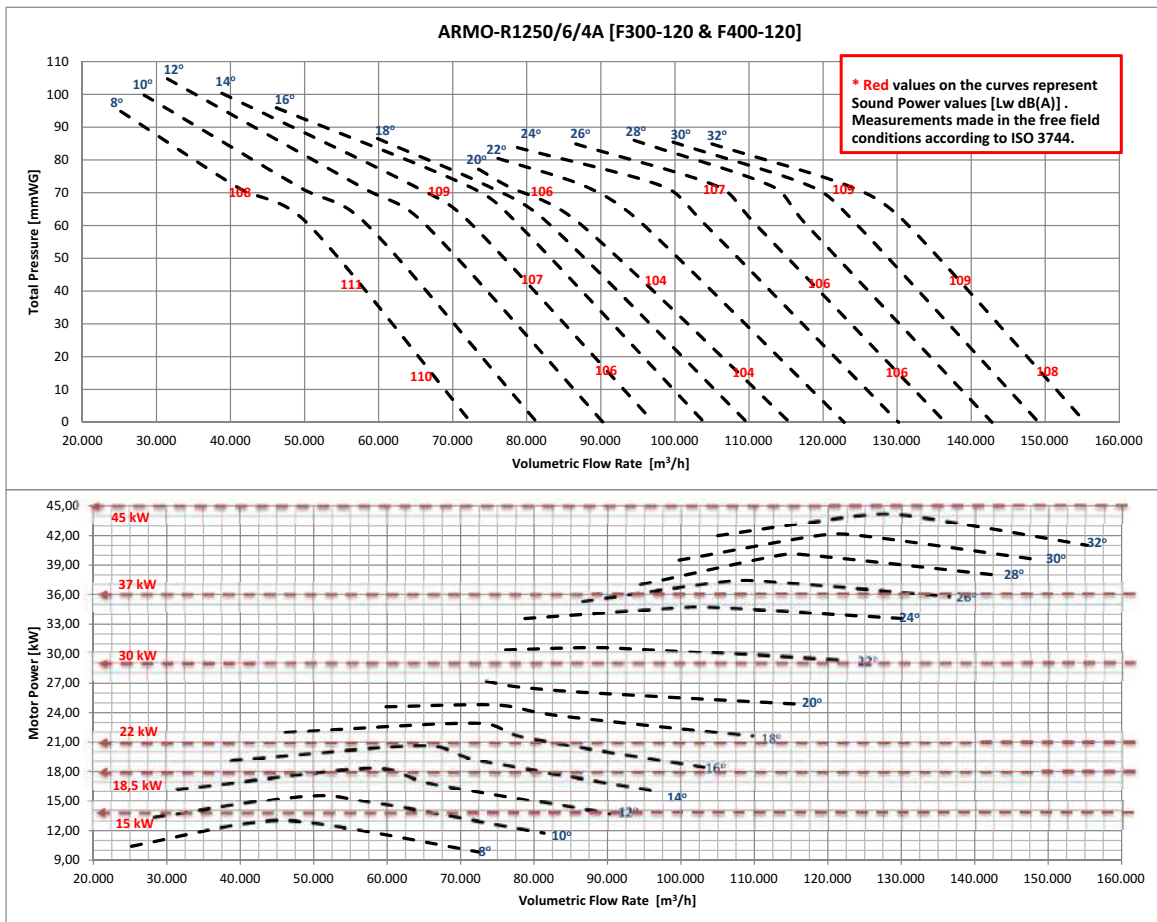
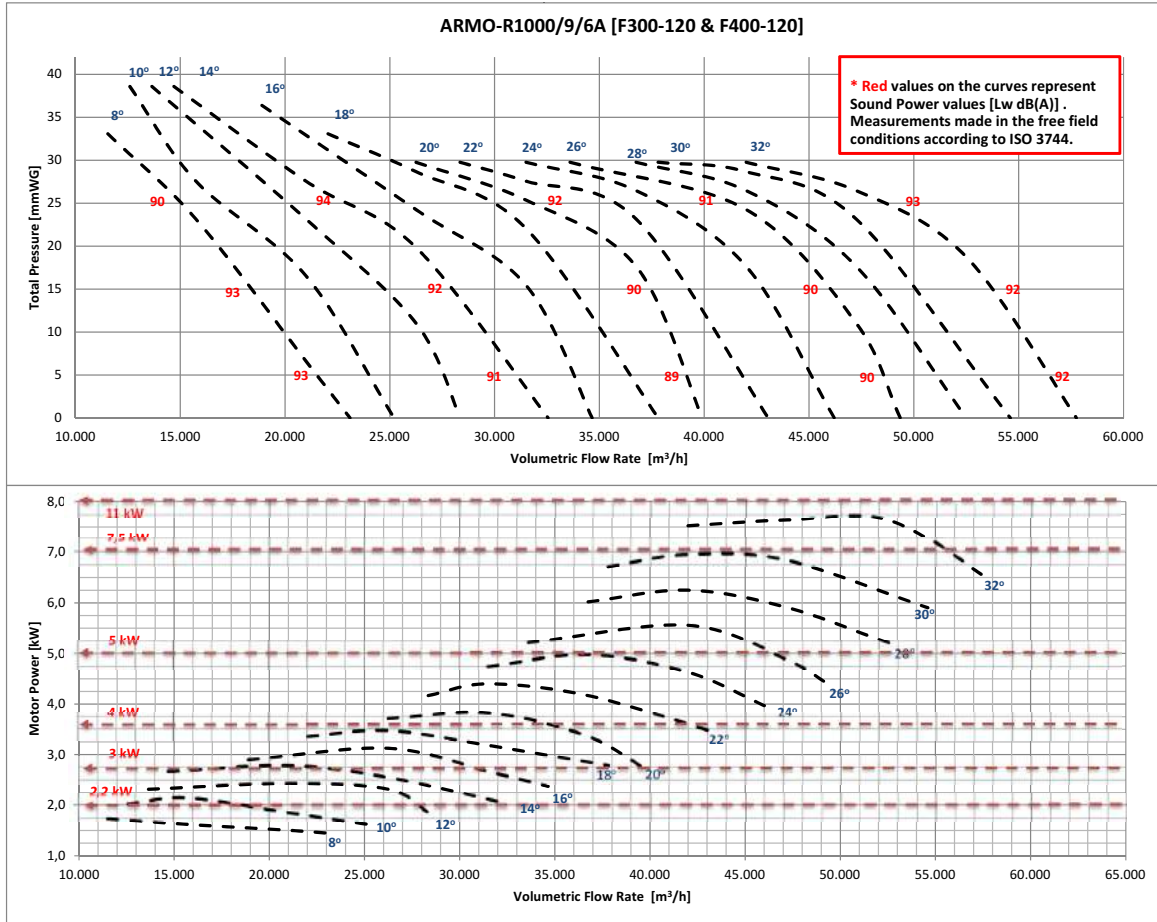

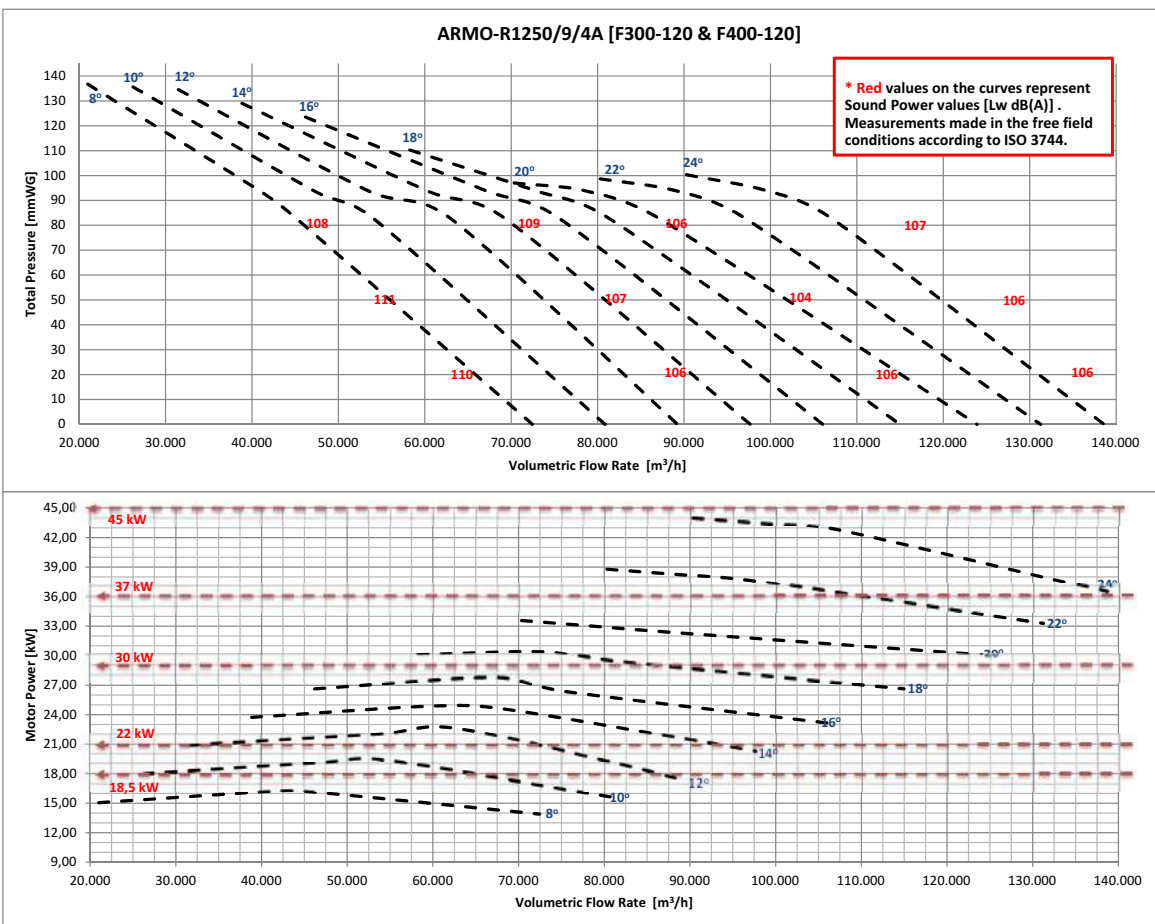
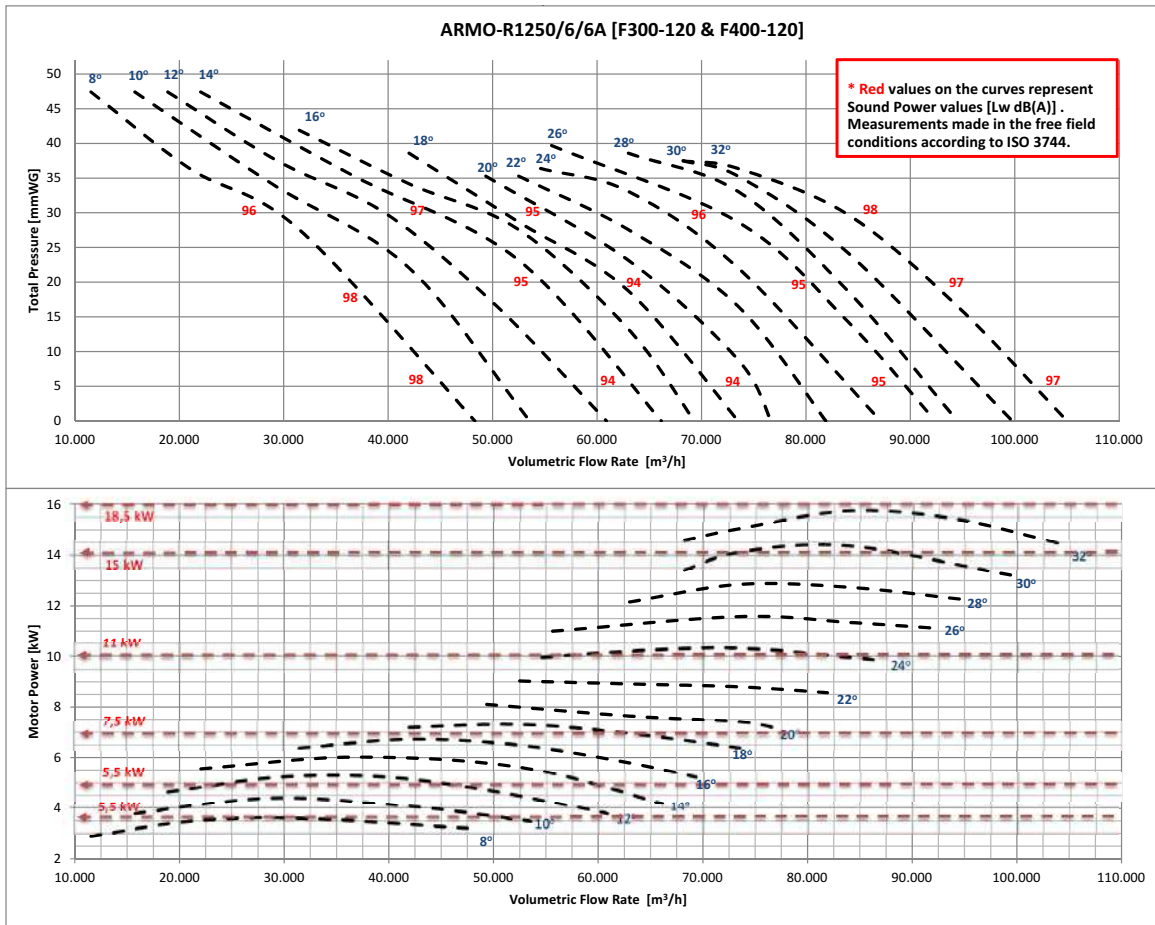

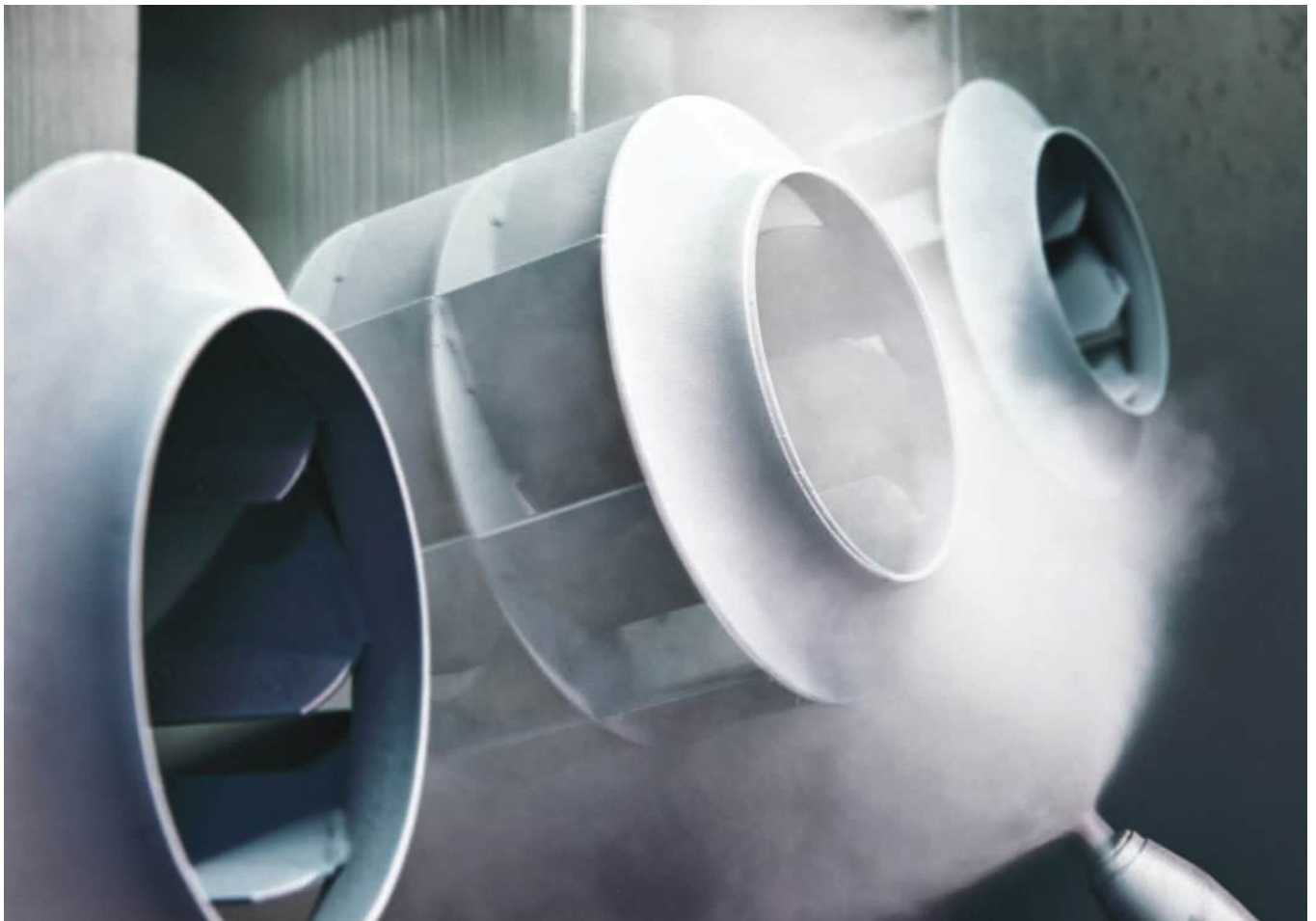
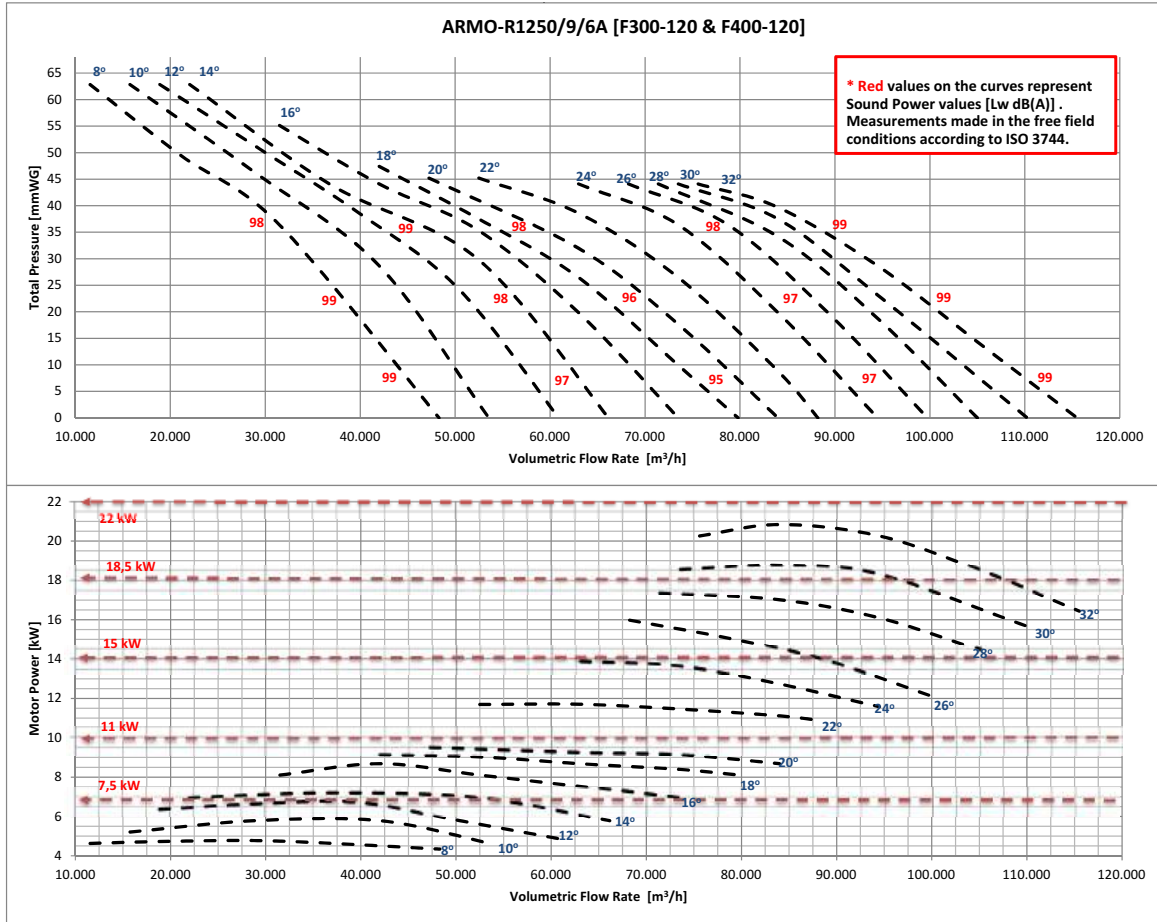



BKEF-R

KITCHEN EXHAUST FANS / Backward Curved

Fan Components and Material Properties

The double-walled body with heat and sound insulation is manufactured from galvanized sheet metal. The fan of the Bkef-R 400 is made of high quality galvanized steel which is resistant to corrosion. The fans of the Bkef-r 450-500-560 models are made of aluminum sheet. All models use an asynchronous motor and the motor is out of airflow. The device is capable of carrying air at max.120°C.

Fan Structure

The fan blades are aerodynamically curved and provide regular flow. The fans are composed of backward sloping and infrequently arranged fins.

*Filtered applications are optional. Please contact BVN representatives.

Benefits

Since the motor is out of airflow, it is resistant to high temperature. The opening cover allows for effortless maintenance of the product. Right-left-top can be changed in three different ways. Water drainage feature. They work quietly thanks to isolation. Speed can be adjusted with speed control devices.

Speed Control

Optional control devices can be provided. Speed control can be done with frequency inverter in 3 ~ phase products. (see BSC-F accessory)

Usage Areas

They are used for smoke evacuation with grease trap filter in dense oily environments such as restaurant kitchens. It is able to carry air at higher temperatures due to the motor being out of airflow.

Technical Drawing and Tables

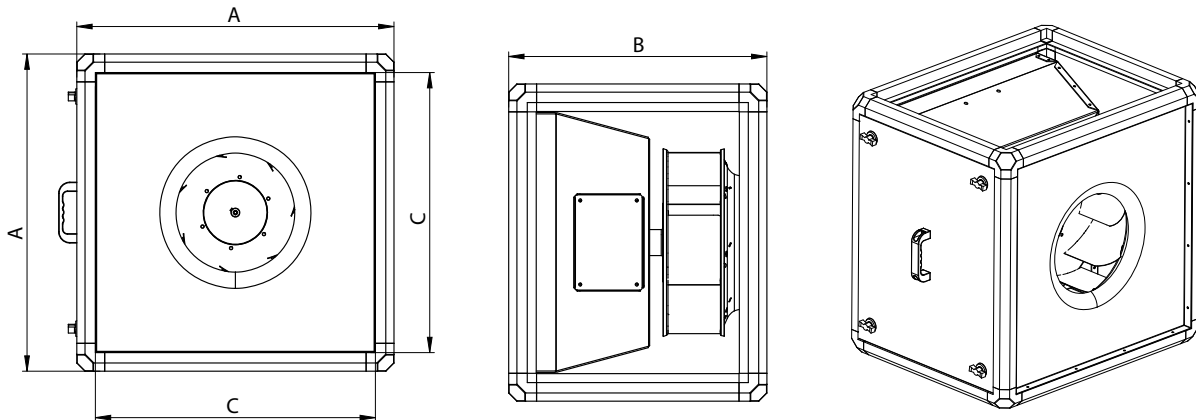

TYPE	A	B	C
BKEF-R 400	683	556	603
BKEF-R 450	683	572	603
BKEF-R 500	683	623	603
BKEF-R 560	813	690	733

Dimensions are in (mm)

TYPE	VOLTAGE	FREQUENCY	POWER	CURRENT	CAPACITOR	SPEED	AIR FLOW	SOUND PRESSURE	INSULATION CLASS	PROTECTION CLASS	WEIGHT
	V	Hz	kW	(A)	(µF)	r.p.m	m³/h	dB(A)	Ins.cl.	IP	kg
BKEF-R 400M	230	50	0,37	3,4	15	1390	4100	45	F	55	52
BKEF-R 450M	230	50	0,55	4,5	20	1365	5400	48	F	55	65
BKEF-R 500M	230	50	1,1	7,5	35	1410	8200	52	F	55	77
BKEF-R 560M	230	50	2,2	14,2	50	1420	10800	55	F	55	95
BKEF-R 400T	380	50	0,37	1,2	-	1390	4100	45	F	55	52
BKEF-R 450T	380	50	0,55	1,6	-	1365	5400	48	F	55	65
BKEF-R 500T	380	50	1,1	2,6	-	1410	8200	52	F	55	77
BKEF-R 560T	380	50	2,2	4,9	-	1420	10800	55	F	55	95

Sound Level Measured from 3m distance in room condition.

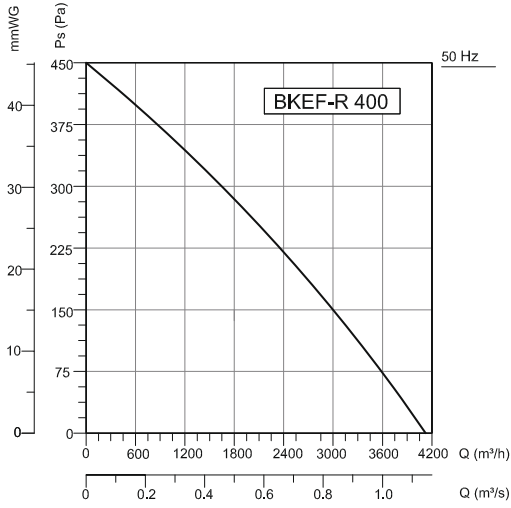

Frequency	Tot	63	125	250	500	1000	2000	4000	8000	Hz
L _{WA} Inlet	68	55	57	61	63	62	59	54	47	dB(A)
L _{WA} Outlet	70	57	59	63	65	64	61	56	49	dB(A)
L _{WA} Surrounding	52	39	41	45	47	46	43	38	31	dB(A)

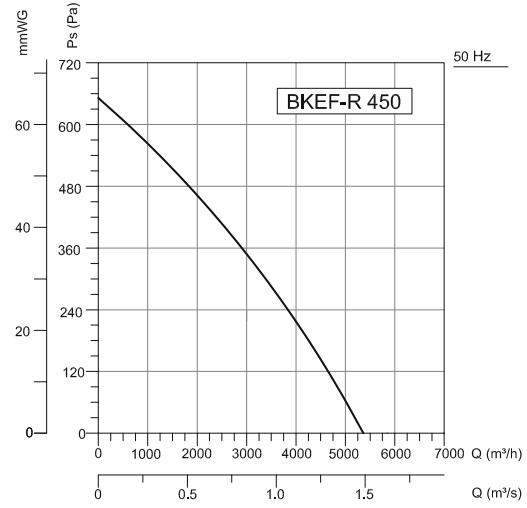

Frequency	Tot	63	125	250	500	1000	2000	4000	8000	Hz
L _{WA} Inlet	70	57	59	63	65	64	61	46	49	dB(A)
L _{WA} Outlet	72	59	61	65	67	66	63	58	51	dB(A)
L _{WA} Surrounding	55	42	44	48	50	49	46	41	34	dB(A)

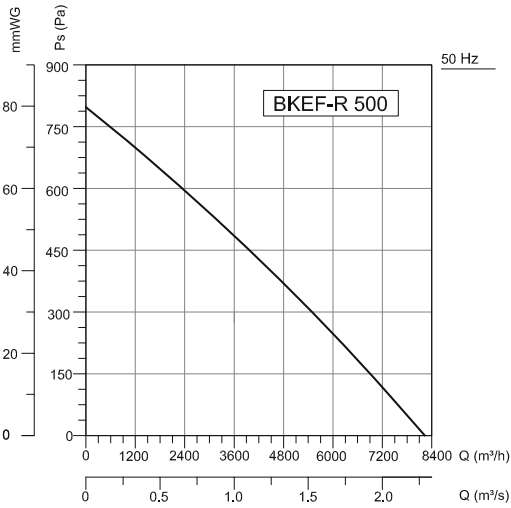

Frequency	Tot	63	125	250	500	1000	2000	4000	8000	Hz
L _{WA} Inlet	74	61	63	67	69	68	65	60	53	dB(A)
L _{WA} Outlet	76	63	65	69	71	70	67	62	55	dB(A)
L _{WA} Surrounding	59	46	48	52	54	53	50	45	38	dB(A)

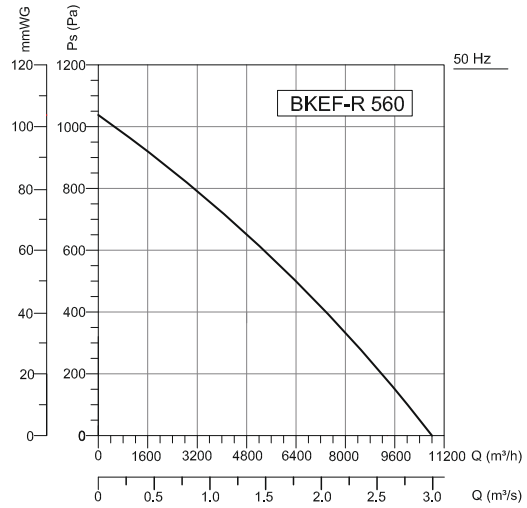

Frequency	Tot	63	125	250	500	1000	2000	4000	8000	Hz
L _{WA} Inlet	76	63	65	69	71	70	67	62	55	dB(A)
L _{WA} Outlet	77	67	66	70	71	71	68	63	56	dB(A)
L _{WA} Surrounding	62	50	52	55	57	56	49	53	42	dB(A)

Accessories





BKEF-RH

KITCHEN EXHAUST FANS / Backward Curved - High Pressure

Fan Components and Material Properties

The double-walled body with heat and sound insulation is manufactured from galvanized sheet metal. 25 mm thick mineral wool was applied for sound and heat insulation. All models of the fan can be removed and installed. All models use asynchronous motor and the motor is out of air flow. The device is capable of carrying air at max.120°C.

Fan Structure

Electrostatic painted and welded plug fan is used. The fan blades are aerodynamically curved and provide regular flow. It is suitable to operate at high speed as it uses a welded plug fan.

*Filtered applications are optional. Please contact BVN representatives.

Benefits

Since the motor is out of airflow, it is resistant to high temperature. It has high performance and high efficiency because it works at high speed. Thanks to the removable panels, smoke can be easily steered. Right-left-top can be changed in three different ways. Water drainage feature. They work quietly thanks to isolation. Occasionally requires wheel cleaning. Speed can be adjusted with speed control devices.

Usage Areas

In restaurants with dense oil like greaseproof environments, it is possible to use commercially available commercial kitchen etc. with smoke trap and long channel distance. Used in environments. It is able to carry air at higher temperatures due to the motor being out of airflow.

Technical Drawing and Tables

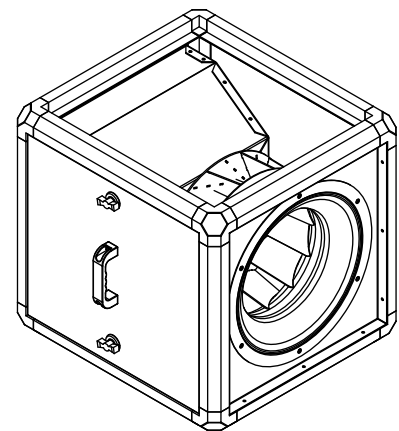
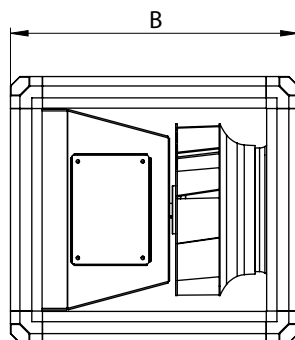
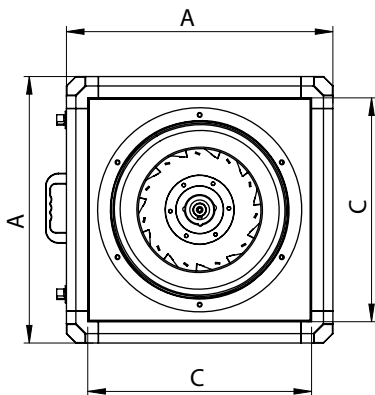

TYPE	A	B	C
BKEF-RH 280	500	500	420
BKEF-RH 315	500	540	420

Dimensions are in (mm)

TYPE	VOLTAGE	FREQUENCY	POWER	CURRENT	CAPACITOR	SPEED	AIR FLOW	SOUND PRESSURE	INSULATION CLASS	PROTECTION CLASS	WEIGHT
	V	Hz	kW	(A)	(µF)	r.p.m	m³/h	dB(A)	Ins.cl.	IP	kg
BKEF-RH 280M	230	50	0,75	5	30	2840	3600	65	F	55	38
BKEF-RH 315M	230	50	1,5	9,8	40	2865	5000	68	F	55	41
BKEF-RH 280T	380	50	0,75	1,8	-	2840	3600	65	F	55	38
BKEF-RH 315T	380	50	1,5	3,3	-	2865	5000	68	F	55	41

Sound Level Measured from 3m distance in room condition.

Accessories



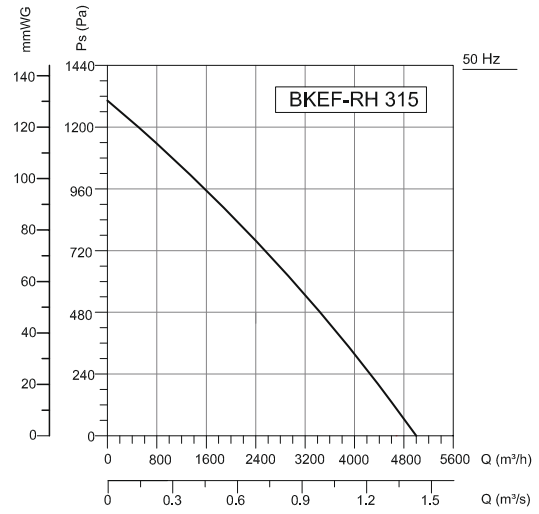
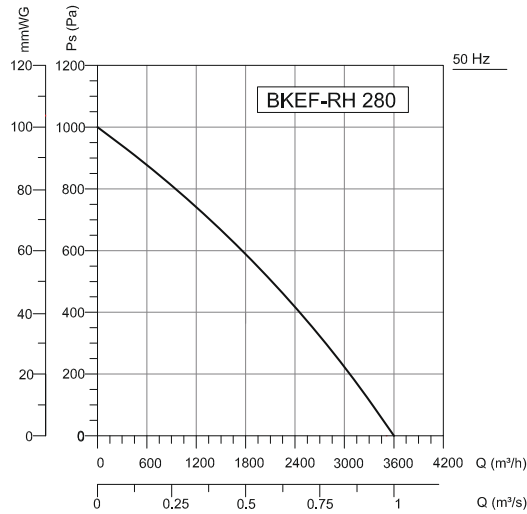

Frequency	Tot	63	125	250	500	1000	2000	4000	8000	Hz
L _{WA} Inlet	86	72	74	78	80	79	76	71	74	dB(A)
L _{WA} Outlet	86	76	75	79	80	80	77	72	65	dB(A)
L _{WA} Surrounding	71	59	61	64	66	65	58	62	51	dB(A)

Frequency	Tot	63	125	250	500	1000	2000	4000	8000	Hz
L _{WA} Inlet	90	76	78	82	84	84	80	75	68	dB(A)
L _{WA} Outlet	90	80	79	83	84	84	82	76	69	dB(A)
L _{WA} Surrounding	75	63	65	68	70	69	62	66	55	dB(A)





BKEF

KITCHEN EXHAUST FANS / Backward Curved

Fan Components and Material Properties

The body with heat and sound insulation is manufactured from galvanized sheet metal. The fans of the Bkef 315-355-400 are made of high quality galvanized steel that is resistant to corrosion. The fans of the Bkef 450-500-560 models are made of aluminum sheet. Asynchronous motor is used in all models. The motor is out of airflow. The device is capable of carrying air at max.120°C.

Fan Structure

The fan blades are aerodynamically curved and provide regular flow. The fans are composed of backward sloping and infrequently arranged fins.

Benefits

Since the motor is out of airflow, it is resistant to high temperature. The opening cover allows for effortless maintenance of the product. Water drainage feature. They work quietly thanks to isolation. Speed can be adjusted with speed control devices.

Speed Control

Optional control devices can be provided. Speed control can be done with frequency inverter in 3~ phase products. (see BSC-F accessory)

Usage Areas

They are used for smoke evacuation with grease trap filter in dense oily environments such as restaurant kitchens. It is able to carry air at higher temperatures due to the motor being out of airflow.

Technical Drawing and Tables

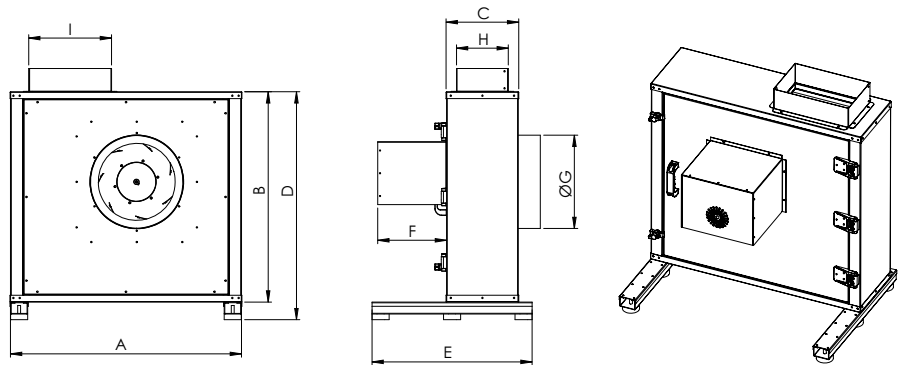

TYPE	A	B	C	D	E	F	G	H	J
BKEF 315	650	605	220	665	480	245	250	160	230
BKEF 355	730	655	230	715	480	245	280	170	260
BKEF 400	815	740	255	800	580	245	330	185	295
BKEF 450	905	810	270	870	580	245	350	210	325
BKEF 500	1005	900	335	990	635	280	400	280	355
BKEF 560	1105	1000	365	1090	715	330	455	310	455

Dimensions are in (mm)

TYPE	VOLTAGE	FREQUENCY	POWER	CURRENT	CAPACITOR	SPEED	AIR FLOW	SOUND PRESSURE	INSULATION CLASS	PROTECTION CLASS	WEIGHT
	V	Hz	kW	(A)	(µF)	r.p.m	m³/h	dB(A)	Ins.cl.	IP	kg
BKEF 315M	230	50	0,25	2,1	10	1390	1800	37-29	F	55	51
BKEF 355M	230	50	0,25	2,1	10	1390	2800	41-33	F	55	63
BKEF 400M	230	50	0,37	3,4	15	1400	4000	42-34	F	55	78
BKEF 450M	230	50	0,55	4,5	20	1410	5200	45-37	F	55	87
BKEF 500M	230	50	1,1	7,5	35	1400	8000	49-42	F	55	120
BKEF 560M	230	50	2,2	14,2	50	1430	10000	52-44	F	55	145
BKEF 315T	380	50	0,25	0,87	-	1380	1800	37-29	F	55	51
BKEF 355T	380	50	0,25	0,87	-	1380	2800	41-33	F	55	63
BKEF 400T	380	50	0,37	1,2	-	1390	4000	42-34	F	55	78
BKEF 450T	380	50	0,55	1,6	-	1365	5200	45-37	F	55	87
BKEF 500T	380	50	1,1	2,6	-	1410	8000	49-42	F	55	120
BKEF 560T	380	50	2,2	4,9	-	1420	10000	52-44	F	55	145

Sound Level Measured from 3m distance in room condition.

Accessories



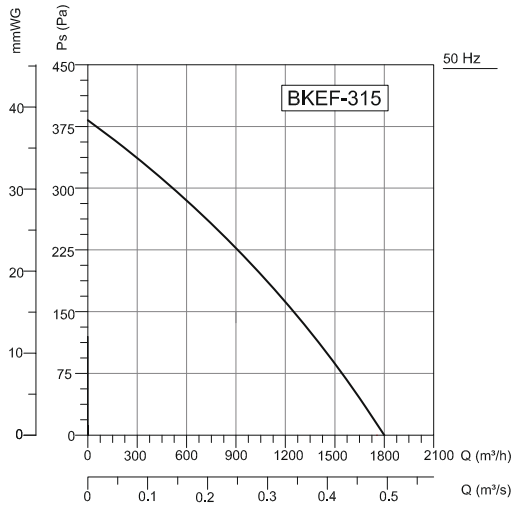

Frequency	Tot	63	125	250	500	1000	2000	4000	8000	Hz
L _{WA} Inlet	78	74	73	68	66	62	56	53	53	dB(A)
L _{WA} Outlet	80	76	75	70	67	64	58	55	55	dB(A)
L _{WA} Surrounding	60	56	55	50	48	44	38	35	35	dB(A)

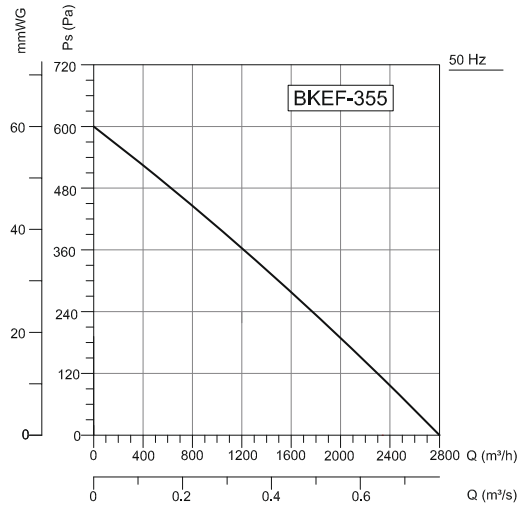

Frequency	Tot	63	125	250	500	1000	2000	4000	8000	Hz
L _{WA} Inlet	82	78	77	72	70	66	60	60	57	dB(A)
L _{WA} Outlet	84	80	79	74	72	68	62	62	59	dB(A)
L _{WA} Surrounding	64	60	59	54	52	48	42	42	39	dB(A)

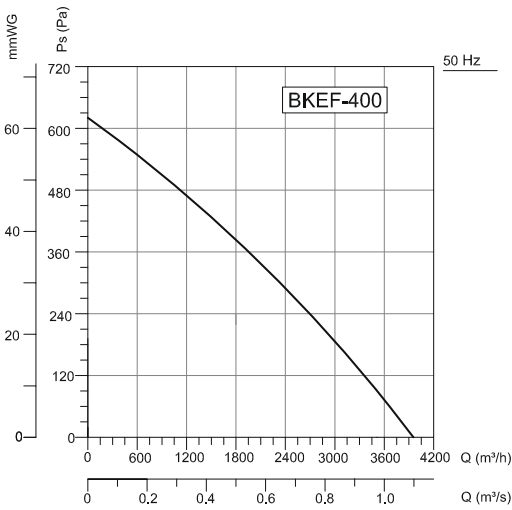

Frequency	Tot	63	125	250	500	1000	2000	4000	8000	Hz
L _{WA} Inlet	83	79	78	73	71	67	61	58	58	dB(A)
L _{WA} Outlet	85	81	80	75	73	69	63	60	60	dB(A)
L _{WA} Surrounding	65	61	60	55	53	49	43	40	40	dB(A)

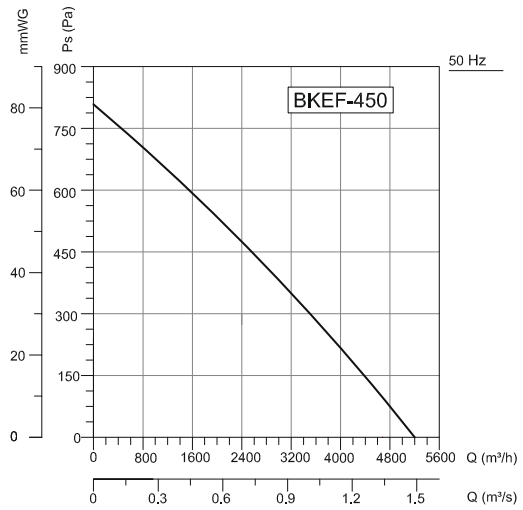

Frequency	Tot	63	125	250	500	1000	2000	4000	8000	Hz
L _{WA} Inlet	86	82	81	76	74	70	64	61	61	dB(A)
L _{WA} Outlet	88	84	83	78	76	75	66	63	63	dB(A)
L _{WA} Surrounding	68	64	63	58	56	52	46	43	43	dB(A)

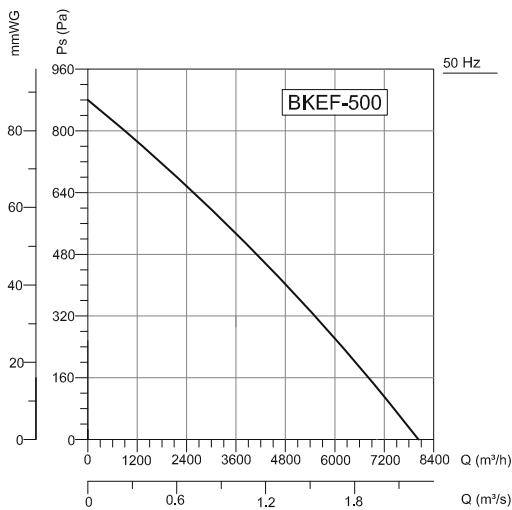

Frequency	Tot	63	125	250	500	1000	2000	4000	8000	Hz
L _{WA} Inlet	88	85	84	79	75	73	67	64	64	dB(A)
L _{WA} Outlet	91	87	86	81	79	78	69	66	66	dB(A)
L _{WA} Surrounding	71	67	66	61	59	55	49	46	46	dB(A)

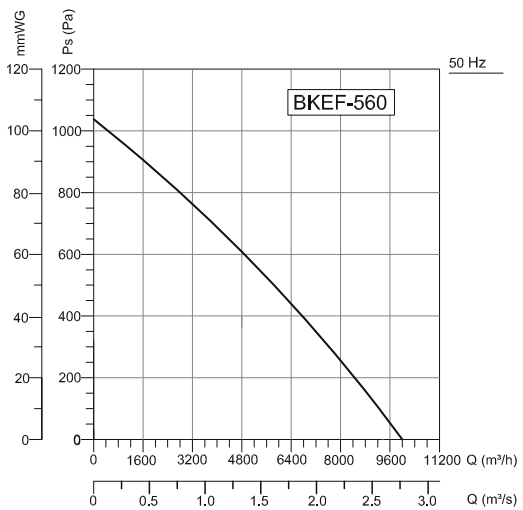

Frequency	Tot	63	125	250	500	1000	2000	4000	8000	Hz
L _{WA} Inlet	91	88	87	82	78	76	70	67	67	dB(A)
L _{WA} Outlet	94	90	89	84	82	81	72	69	69	dB(A)
L _{WA} Surrounding	74	70	69	64	62	58	52	49	49	dB(A)



BKEF-T

KITCHEN FANS / Forward Curved

Fan Components and Material Properties

The rectangular body and the impellers of the fans are made of high quality galvanized steel which is resistant to corrosion. Motor protection cover. The BSKF-R is equipped with an asynchronous motor outside the air flow. The device is capable of carrying air at max.120°C.

Fan Structure

Double-walled galvanized body and galvanized forward inclined fan impeller. The fan blades are forward-curved, combined with the plug-in technique and produced in an aerodynamic manner to ensure regular flow. It is designed to work between the rectangular channel. Opening direction interchangeable cover is available.

Benefits

Since the motor is out of airflow, it is resistant to high temperature. The swing-out lid allows the product to

be maintained effortlessly without removing the fan. The housing with fan connection and anti-vibration mountings are included in the isolated base frame. Thanks to the aerodynamic wing structure, they work quietly. Speed can be adjusted with speed control devices. 50 mm thick mineral wool was applied for sound and heat insulation. Water drainage feature.

Speed Control

Optional control devices can be provided. 3 ~ phase products can be controlled with frequency inverter speed control. (see BSC-F accessory)

Usage Areas

It is able to carry air at higher temperatures due to the motor being out of airflow. It should be used with a filter in kitchens that do not contain oil particles. The kitchen can also be used for ambient air ventilation. In order to achieve long service life, fan blade cleaning should be considered.

Technical Drawing and Tables

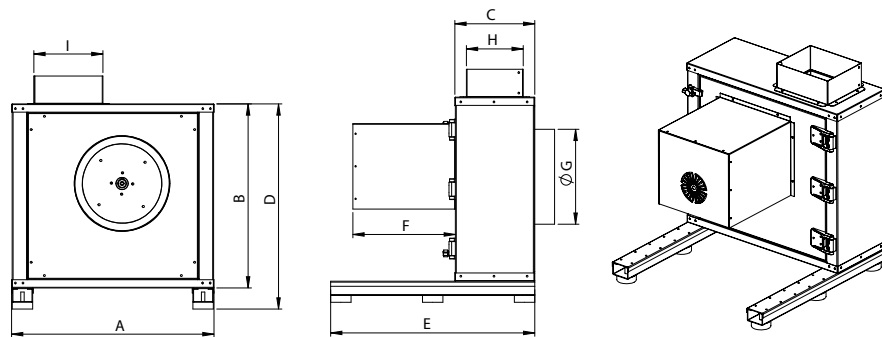

TYPE	A	B	C	D	E	F	G	H	I
BKEF-T 200	460	415	210	475	500	240	200	145	145
BKEF-T 225	495	460	210	520	500	240	210	145	165
BKEF-T 250	535	480	230	545	550	300	250	165	180
BKEF-T 280	595	540	235	605	600	300	280	170	205
BKEF-T 315	650	600	265	660	650	340	335	188	225
BKEF-T 355	730	660	310	820	650	405	340	210	256

Dimensions are in (mm)

TYPE	VOLTAGE	FREQUENCY	POWER	CURRENT	CAPACITOR	SPEED	AIR FLOW	SOUND PRESSURE	INSULATION CLASS	PROTECTION CLASS	WEIGHT
	V	Hz	kW	(A)	(µF)	r.p.m	m³/h	dB(A)	Ins.cl.	IP	kg
BKEF-T 200M	230	50	0,55	4,5	20	1365	1750	40	F	55	40
BKEF-T 225M	230	50	0,75	4,6	30	1405	2250	42	F	55	43
BKEF-T 250M	230	50	1,5	9,3	50	1410	3500	45	F	55	52
BKEF-T 280M	230	50	1,5	9,3	50	1410	4200	48	F	55	63
BKEF-T 315M	230	50	3	19	60	1425	5000	50	F	55	78
BKEF-T 200T	380	50	0,55	1,6	-	1365	1750	40	F	55	40
BKEF-T 225T	380	50	0,75	2,1	-	1405	2250	42	F	55	43
BKEF-T 250T	380	50	1,5	3,5	-	1410	3500	45	F	55	52
BKEF-T 280T	380	50	1,5	3,5	-	1410	4200	48	F	55	63
BKEF-T 315T	380	50	3	6,9	-	960	5000	50	F	55	78
BKEF-T 355T	380	50	3	6,9	-	960	6000	45	F	55	85

Sound Level Measured from 3m distance in room condition.

Accessories



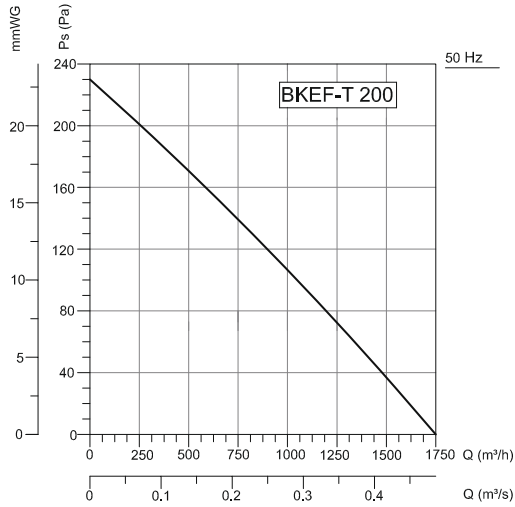

Frequency	Tot	63	125	250	500	1000	2000	4000	8000 Hz
L_{WA} Inlet	81	79	75	72	68	66	62	58	58 dB(A)
L_{WA} Outlet	83	81	77	74	70	68	64	60	60 dB(A)
L_{WA} Surrounding	63	61	57	54	50	48	44	40	40 dB(A)

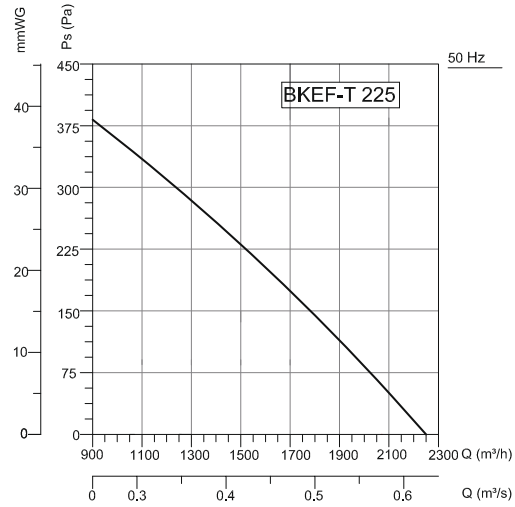

Frequency	Tot	63	125	250	500	1000	2000	4000	8000 Hz
L_{WA} Inlet	83	81	77	74	70	68	64	60	60 dB(A)
L_{WA} Outlet	85	83	79	76	72	70	66	62	62 dB(A)
L_{WA} Surrounding	65	63	59	56	52	50	46	42	42 dB(A)

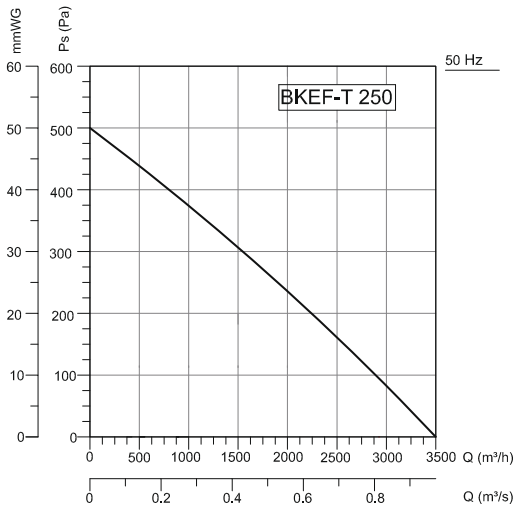

Frequency	Tot	63	125	250	500	1000	2000	4000	8000 Hz
L_{WA} Inlet	89	84	86	75	73	72	68	64	64 dB(A)
L_{WA} Outlet	88	86	81	80	75	74	69	64	64 dB(A)
L_{WA} Surrounding	68	65	61	60	56	54	49	45	45 dB(A)

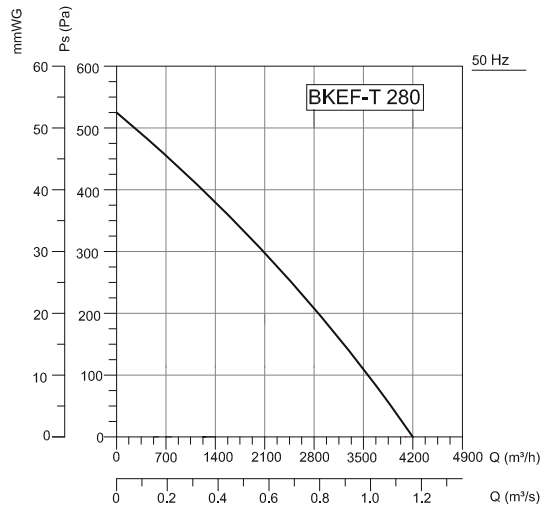

Frequency	Tot	63	125	250	500	1000	2000	4000	8000 Hz
L_{WA} Inlet	89	87	83	80	76	74	70	66	66 dB(A)
L_{WA} Outlet	91	89	85	82	78	76	72	68	68 dB(A)
L_{WA} Surrounding	71	69	65	62	58	56	52	46	46 dB(A)

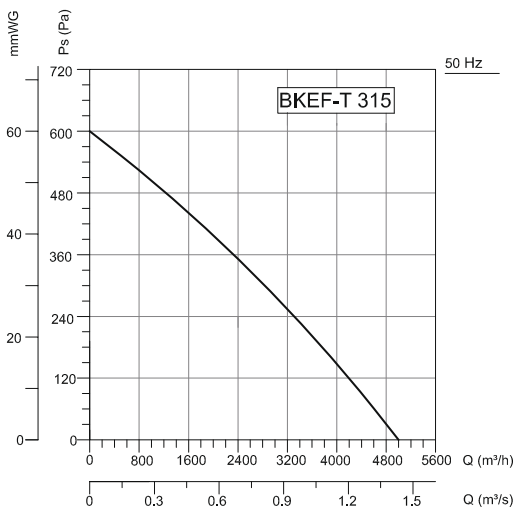



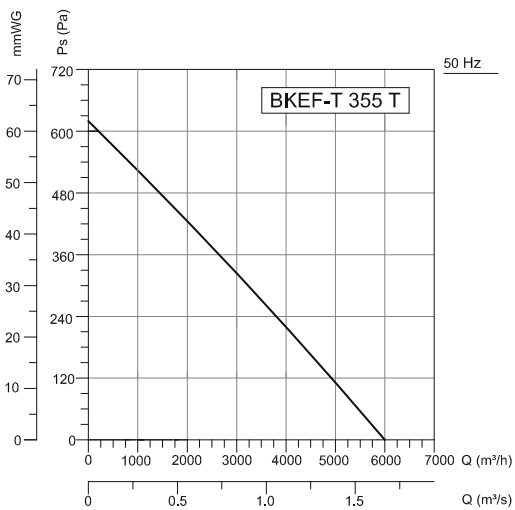

Frequency	Tot	63	125	250	500	1000	2000	4000	8000 Hz
L_{WA} Inlet	91	89	85	82	78	76	72	68	68 dB(A)
L_{WA} Outlet	93	91	87	84	80	78	74	70	70 dB(A)
L_{WA} Surrounding	73	71	67	64	60	58	54	48	48 dB(A)



Frequency	Tot	63	125	250	500	1000	2000	4000	8000 Hz
L_{WA} Inlet	88	84	85	76	72	73	68	64	64 dB(A)
L_{WA} Outlet	87	85	80	79	74	73	68	63	63 dB(A)
L_{WA} Surrounding	68	65	61	60	56	54	49	45	45 dB(A)



 (+90) 212 771 48 48  (+90) 212 771 48 42
 info@bvnair.com
 Ömerli Mah. İstanbul Cd. No:147
34555 Arnavutköy / İstanbul-TÜRKİYE